

# INTEGRATED VOICE EVACUATION SYSTEM

## VX-2000 series

Thank you for purchasing TOA's Integrated Voice Evacuation System.  
Please carefully follow the instructions in this manual to ensure long, trouble-free use of your equipment.

 1134
TOA Electronics Europe GmbH Suederstrasse 282, 20537 Hamburg, Germany 1134-CPR-110 14 DoP 14-002
EN 54-16: 2008 Fire detection and fire alarm systems – Part 16: Voice alarm control and indicating equipment Options: Audible warning of emergency Manual silencing of the voice alarm condition Manual reset of the voice alarm condition Voice alarm condition output to CIE Indication of faults related to voice alarm zones Emergency microphone(s) Voice alarm manual control Redundant power amplifiers

When an EN 54-16 compliant VX-2000 system has to be installed, then carefully read the separate manual titled "APPENDIX: ADDITIONAL INSTALLATION INSTRUCTIONS FOR AN EN 54-16 COMPLIANT SYSTEM" and follow up the installation and configuration requirements explained therein. This APPENDIX contains the basic description of settings and installations, so please refer to the general instruction sections in this document for more details.

**Note**

Refer to the Instruction Manual attached to the VX-2000DS/3000DS for the installation of the the VX-2000DS or VX-3000DS Emergency power supply, the VX-2000PF Power supply frame, and the VX-200PS Power supply unit.

# TABLE OF CONTENTS

<b>SAFETY PRECAUTIONS</b> .....	10
---------------------------------	----

## ***Chapter 1: NOTE***

<b>1. GENERAL DESCRIPTION</b> .....	1-2
<b>2. SYSTEM FEATURES</b> .....	1-3
<b>3. HANDLING PRECAUTIONS</b> .....	1-5

## ***Chapter 2: PRODUCT DESCRIPTIONS***

<b>1. MAXIMUM SYSTEM EXAMPLE</b> .....	2-2
1.1. Block Diagram .....	2-2
1.2. Maximum System Configuration Table .....	2-3
<b>2. NOMENCLATURE AND FUNCTIONS</b> .....	2-4
2.1. Fireman's Microphone RM-200XF .....	2-4
2.2. Remote Microphone RM-200X .....	2-6
2.3. Remote Microphone Extension RM-210 .....	2-8
2.4. System Manager VX-2000 .....	2-9
2.5. Voice Announcement Board EV-200 .....	2-11
2.6. Remote Microphone Input Module VX-200XR .....	2-12
2.7. Audio Input Module with Control input VX-200XI .....	2-13
2.8. Surveillance Frame VX-2000SF .....	2-14
2.9. Pilot Tone Detection Module VX-200SP .....	2-16
2.10. Impedance Detection Module VX-200SZ .....	2-17
2.11. Equaliser Card VX-200SE .....	2-18
2.12. Control Input Module VX-200SI .....	2-19
2.13. Control Output Module VX-200SO .....	2-20
2.14. Power Amplifiers VP-2064, VP-2122, VP-2241, and VP-2421 .....	2-21
2.15. Power Amplifiers VP-3154, VP-3304, and VP-3504 .....	2-22
2.16. Power Amplifier Input Module VP-200VX .....	2-24

## ***Chapter 3: SYSTEM OPERATION OUTLINE***

<b>1. OPERATION MODES</b> .....	3-2
1.1. Drive Mode .....	3-2
1.2. System Operation Mode .....	3-2
<b>2. MONITOR FUNCTION</b> .....	3-3
2.1. Continuous Monitoring .....	3-3
2.2. Monitoring That Requires Interval Settings .....	3-4
<b>3. AMPLIFIER STANDBY FUNCTIONS</b> .....	3-5
<b>4. SPEAKER LINE FAILURE DETECTION METHODS</b> .....	3-6
4.1. Impedance Detection Method .....	3-6
4.2. Pilot Tone Detection Method .....	3-6

<b>5. EXTERNAL ATTENUATOR CONTROL</b>	
<b>TERMINAL OPERATION</b> .....	3-7
5.1. Operation .....	3-7
5.2. Operation During Monitoring .....	3-8
<b>6. CPU SWITCH</b> .....	3-9
<b>7. SWITCHING OFF SYSTEM POWER</b> .....	3-10
<b>8. BROADCAST PRIORITIES</b> .....	3-11
8.1. Duplicate Broadcasts from both Higher and Lower Priority Equipment .....	3-12
8.2. FIFO/LIFO Priorities .....	3-13
8.3. Broadcasts from the Daisy-Chain Connected Remote Microphones .....	3-14

<b>Chapter 4: FUNCTIONS</b>
-----------------------------

<b>1. OPERATION OUTLINE</b> .....	4-2
<b>2. PATTERNS</b> .....	4-3
2.1. Emergency Broadcast Patterns .....	4-3
2.2. Control/General-Purpose Broadcast Patterns .....	4-4
2.3. Failure Output Patterns .....	4-5
<b>3. ACTIVATION ITEMS</b> .....	4-6
3.1. Remote Microphone Function Keys .....	4-6
3.1.1. Emergency .....	4-7
3.1.2. Base pattern change .....	4-8
3.1.3. Base pattern end .....	4-8
3.1.4. Control output interlock .....	4-8
3.1.5. Audio monitoring .....	4-8
3.1.6. Volume UP operation .....	4-9
3.1.7. Volume DOWN operation .....	4-9
3.1.8. Failure output reception .....	4-9
3.1.9. Failure output reset .....	4-9
3.1.10. Zone selection .....	4-10
3.1.11. All-Zone selection .....	4-10
3.1.12. Clear .....	4-10
3.1.13. Talk .....	4-11
3.1.14. General-Purpose EV Message .....	4-12
3.1.15. Chime .....	4-12
3.2. Control Input .....	4-13
3.3. Internal Timer .....	4-14
3.3.1. Preparing day programs .....	4-14
3.3.2. Timer management .....	4-15
3.3.3. Summer time settings .....	4-16
3.4. Activation Item Function Table .....	4-17

## **Chapter 5: OPERATION**

<b>1. OPERATING THE REMOTE MICROPHONE BY USING A PASSWORD</b> .....	5-2
1.1. Entering a Password .....	5-2
1.2. Bringing the Remote Microphone into Password Entry Status .....	5-2
<b>2. EMERGENCY BROADCASTS</b> .....	5-3
2.1. Dual-Origin EV Message Broadcast .....	5-3
2.2. Single-Origin EV Message Broadcast (Sequential Operation) .....	5-8
2.3. Emergency Mode Activation and Reset .....	5-12
<b>3. GENERAL-PURPOSE BROADCAST</b> .....	5-19
3.1. Making Announcements from the Remote Microphone .....	5-20
3.2. Making BGM Broadcasts .....	5-22
3.2.1. Recalling base patterns using the internal timer .....	5-22
3.2.2. Recalling base patterns from the Remote Microphone .....	5-24
3.3. Changing the Input Sensitivity and Output Volume Level .....	5-26
3.3.1. Changing the input sensitivity and output volume level at the Remote Microphone .....	5-26
3.3.2. Changing the input sensitivity and output volume by way of the control input or internal timer .....	5-29
3.4. Interrupt Broadcasts .....	5-30
3.5. EV Message Broadcasts .....	5-31
3.5.1. Making EV broadcasts from the Remote Microphone .....	5-31
3.5.2. Making EV broadcasts by way of the control input or internal timer .....	5-32
<b>4. AUDIO MONITORING</b> .....	5-33
4.1. Monitoring by means of a Remote Microphone .....	5-33
4.2. Monitoring by means of the VX-2000's MONITOR OUT Terminal .....	5-33
<b>5. FAILURE OUTPUT DETECTION</b> .....	5-34
5.1. Failure Output Indication .....	5-34
5.2. Monitoring Log List .....	5-37

## **Chapter 6: FLOWCHART FROM SYSTEM SETUP TO OPERATION**

<b>1. PROCEDURE TO SYSTEM OPERATION</b> .....	6-2
---	-----

## **Chapter 7: PC SOFTWARE OFFLINE SETTINGS**

<b>1. SETUP PROCEDURE (from installation to settings)</b> .....	7-2
<b>2. HARDWARE REQUIREMENT</b> .....	7-4
<b>3. SOFTWARE INSTALLATION</b> .....	7-5
<b>4. SCREEN AND MENU DESCRIPTIONS</b> .....	7-8
4.1. Screen .....	7-8
4.2. Menu .....	7-9
<b>5. VX-2000 SETTING SOFTWARE ACTIVATION</b> .....	7-10

<b>6. NEW FILE CREATION</b> .....	7-11
<b>7. CONFIGURATION SETTING MODE</b> .....	7-13
7.1. SF Module Properties Setting .....	7-13
7.2. Control Output Name Setting .....	7-19
7.3. VX-2000 Properties Settings .....	7-20
7.4. Remote Microphone Properties Settings .....	7-23
7.5. Remote Microphone (RM) Unit Expansion .....	7-25
7.6. Electronic Voice File (EV) Unit Message Types .....	7-28
7.7. Monitor Settings .....	7-29
<b>8. SYSTEM SETTING MODE</b> .....	7-30
8.1. Broadcast Priority Settings .....	7-30
8.1.1. Emergency RM .....	7-31
8.1.2. Emergency EV .....	7-32
8.1.3. General (General-Purpose Broadcast) .....	7-33
8.1.4. BGM .....	7-34
8.2. Initial Volume Settings .....	7-35
8.2.1. Initial source input volume settings .....	7-35
8.2.2. Initial output volume settings .....	7-36
8.3. Equaliser Settings .....	7-37
<b>9. OPERATION SETTING MODE</b> .....	7-39
9.1. Emergency Broadcast Settings .....	7-39
9.1.1. When no EV units are used .....	7-39
9.1.2. When using a single EV unit .....	7-40
9.1.3. When using 2 EV units .....	7-42
9.2. Pattern Creation .....	7-45
9.2.1. Control output interlock pattern .....	7-45
9.2.2. Interrupt broadcast pattern .....	7-46
9.2.3. EV broadcast pattern .....	7-47
9.2.4. Base pattern .....	7-48
9.2.5. Volume pattern .....	7-50
9.3. Failure Output Pattern Creation .....	7-51
<b>10. ACTIVATION SETTING MODE</b> .....	7-52
10.1. Remote Microphone Function Key Assignment .....	7-52
10.2. Control Input Settings .....	7-56
10.3. Timer Settings .....	7-58
10.3.1. Day programs .....	7-58
10.3.2. Weekly program .....	7-60
10.3.3. Holiday programs .....	7-61
10.3.4. Summer time .....	7-62
<b>11. PRINTING OUT SETTING DATA</b> .....	7-63

## **Chapter 8: INSTALLATION AND SETTING PROCEDURES (HARDWARE)**

<b>1. RM-200XF AND RM-200X MICROPHONES</b> .....	8-2
1.1. DIP Switch Settings .....	8-2
1.1.1. DIP switch functions .....	8-2
1.1.2. Unit ID number settings (Switches 1 – 4) .....	8-3
1.1.3. Microphone input sensitivity adjustment using Level Meter Mode (Switch 5) .....	8-4
1.1.4. Compression settings (Switch 6) .....	8-5
1.1.5. Enable/Disable switching for the Emergency button and Function key 2 (Switches 7 and 8, and RM-200XF only) .....	8-5
1.2. RM-200XF Wall Mounting .....	8-6
1.3. Mounting the Assembly of RM-200XF and Its Extension RM-210 on a Wall ....	8-8
1.4. RM-200X Wall Mounting .....	8-10
1.5. Mounting the Assembly of RM-200X and Its Extension RM-210 on a Wall ....	8-11
1.6. RM-200X Expansion With the Addition of the RM-210 (Installed on a Flat Surface) .....	8-13
1.7. Creating Remote Microphone Name Labels .....	8-14
<b>2. VX-2000, VX-200XR, VX-200XI, AND EV-200</b> .....	8-15
2.1. Removing the VX-2000's Top and Front Panels .....	8-15
2.2. Changing the RS-232C Connector Location .....	8-16
2.3. Insulating the VX-2000 Control I/O .....	8-17
2.4. Installing the Insulating Transformer in the VX-2000 System Manager .....	8-18
2.5. Mounting the EV-200 Voice Announcement Board on the VX-2000 System Manager .....	8-19
2.6. Setting the VX-200XI Audio Input Module DIP Switch .....	8-21
2.7. Insulating the VX-200XI Control and Audio Inputs .....	8-22
2.8. Mounting the VX-200XR and VX-200XI in the VX-2000 System Manager ....	8-23
2.9. VX-2000 System Manager's DIP Switch Settings .....	8-23
2.9.1. DIP switch functions .....	8-23
2.9.2. Setting the VX-2000's UK standby mode (switch 5) .....	8-23
<b>3. VX-2000SF, VX-200SZ , VX-200SP, VX-200SI , VX-200SO, AND VX-200SE</b> .....	8-24
3.1. VX-2000SF Surveillance Frame's DIP Switch Settings .....	8-24
3.1.1. DIP switch functions .....	8-24
3.1.2. Setting the unit ID number for the VX-2000SF Surveillance Frame ....	8-25
3.1.3. Setting the VX-2000SF's terminator (switch 5) .....	8-26
3.2. Installing the Insulating Transformer in the VX-2000SF Surveillance Frame .	8-27
3.3. Changing the VX-200SZ's ATT CTRL Output to Photocoupler Type .....	8-29
3.4. Installing the VX-200SE in the VX-200SZ and VX-200SP .....	8-30
3.5. Changing the VX-200SI's Logic .....	8-31
3.6. Insulating the VX-200SI .....	8-32
3.7. Installing Modules (VX-200SZ, VX-200SP, VX-200SI, and VX-200SO) .....	8-33
in the VX-2000SF Frame .....	8-33
<b>4. VP-2064, VP-2122, VP-2241 AND VP-2421 POWER AMPLIFIERS</b> .....	8-34
4.1. Removing the VP Power Amplifier's Top Panel .....	8-34
4.2. Changing the Speaker Line Voltage .....	8-34

4.3. Installing the VP-200VX Power Amplifier Input Module in the VP Power Amplifiers .....	8-36
4.4. Ground Lifting Using the VP-200VX Power Amplifier Input Module .....	8-38
4.5. Replacing the Blade Fuse .....	8-39
<b>5. VP-3154, VP-3304 AND VP-3504 POWER AMPLIFIERS</b> ..	8-40
5.1. Changing the Speaker Line Voltage .....	8-40
5.2. Ground Lifting .....	8-41
5.3. BGM Input Sensitivity Setting .....	8-42
5.4. Replacing the Fuse .....	8-43
<b>6. RACK MOUNTING</b> .....	8-44
<b>Chapter 9: CONNECTIONS</b>	
<b>1. VX-2000 CONNECTIONS TO REMOTE MICROPHONES AND INPUT SOURCE EQUIPMENT</b> .....	9-2
<b>2. CONNECTIONS BETWEEN VX-2000 AND VX-2000SF</b> .....	9-3
<b>3. SF MODULES (VX-200SP, VX-200SZ, VX-200SI, VX-200SO) CONNECTIONS</b> .....	9-4
3.1. SF Modules Configuration Example .....	9-4
3.2. VX-200SP and VX-200SZ Connection to Power Amplifier and Speakers .....	9-4
3.3. VX-200SP Connection to External Attenuator .....	9-7
3.3.1. 3-wire system connection .....	9-7
3.3.2. 4-wire system connection .....	9-7
3.4. VX-200SZ Connection to External Attenuator .....	9-7
3.5. VX-200SI and VX-200SO Connection to External Devices .....	9-8
<b>4. CONNECTIONS BETWEEN VX-2000SF AND STANDBY AMPLIFIER</b> .....	9-9
<b>5. VX-2000 CABLE USAGE TABLE</b> .....	9-11
<b>6. CONNECTION CABLE PIN ASSIGNMENT</b> .....	9-16
6.1. RJ45 Connector-to-RJ45 Connector Connections .....	9-16
6.2. VX-200XR to Remote Microphone (RM-200XF or RM-200X) Connections .....	9-17
6.3. VX-200XI Connections .....	9-22
6.4. VX-2000 Control Input Connections .....	9-24
6.5. VX-2000 Control Output Connections .....	9-28
6.6. VX-200SI Connections .....	9-30
6.7. VX-200SO Connections .....	9-33
<b>7. CABLE DISTANCE BETWEEN COMPONENTS</b> .....	9-35
7.1. VX-2000 to Remote Microphone Cable Distance .....	9-35
7.2. VX-200XR to Remote Microphone Cable Distance Extension .....	9-36
7.2.1. Mount the Repeater on the VX-200XR and set the Free Topology .....	9-36
7.2.2. Mount the Repeater on the VX-200XR and set the Doubly Terminated Bus Topology .....	9-38
7.3. Cable Distance between the VX-2000 and VX-2000SF .....	9-43

## **Chapter 10: PC ONLINE CHECKS AND ADJUSTMENTS**

<b>1. SYSTEM SETUP PROCEDURE</b> .....	10-2
<b>2. SYSTEM SETTING FILE DOWNLOAD</b> .....	10-3
2.1. Connections between VX-2000 and pc .....	10-3
2.2. VX-2000 Setting Software Activation .....	10-4
2.3. General Settings .....	10-5
2.3.1. Communication Port Settings .....	10-5
2.3.2. Current Date/Time Settings .....	10-6
2.4. System Setting File Download .....	10-7
<b>3. SYSTEM CHECK FUNCTIONS</b> .....	10-8
3.1. Configuration Check .....	10-8
3.2. Initial Impedance Settings .....	10-10
3.2.1. Using the PC software initial impedance settings .....	10-11
3.2.2. Using the VX-2000SF's initial setting switch .....	10-12
3.3. Connection Check .....	10-13
<b>4. VOLUME AND EQUALISER SETTINGS</b> .....	10-15
4.1. Initial Volume Settings .....	10-15
4.2. Equaliser Settings .....	10-16

## **Chapter 11: OTHER PC SOFTWARE FUNCTIONS**

<b>1. MONITOR OPERATION CHECK</b> .....	11-2
<b>2. SYSTEM SETTING FILE UPLOAD</b> .....	11-5
<b>3. READING LOGS</b> .....	11-7
<b>4. VERSION DISPLAY</b> .....	11-10

## **Chapter 12: APPENDIX**

<b>1. CF CARD RECORDING METHODS</b> .....	12-2
1.1. Recording by the EV-350R .....	12-2
1.1.1. Program .....	12-2
1.1.2. CF Card Recording Contents .....	12-3
1.1.3. Setting Example .....	12-4
1.1.4. Usable CF cards (their card adapter required) .....	12-5
1.2. Recording by the EV-200 Data Edit Software .....	12-6

## **Chapter 13: SPECIFICATIONS**

<b>1. BLOCK DIAGRAM</b> .....	13-2
1.1. Fireman's Microphone RM-200XF .....	13-2
1.2. Remote Microphone RM-200X .....	13-3
1.3. Remote Microphone Input Module VX-200XR .....	13-4
1.4. Audio Input Module with Control Input VX-200XI .....	13-4
1.5. System Manager VX-2000 .....	13-5
1.6. Surveillance Frame VX-2000SF .....	13-6
1.7. Pilot Tone Detection Module VX-200SP .....	13-7



1.8. Impedance Detection Module VX-200SZ .....	13-8
1.9. Power Amplifier Input Module VP-200VX .....	13-9
1.10. Power Amplifier 1 x 240 W VP-2241 and Power Amplifier 1 x 420 W VP-2421 .....	13-9
1.11. Power Amplifier 2 x 120 W VP-2122 .....	13-10
1.12. Power Amplifier 4 x 60 W VP-2064 .....	13-11
1.13. Power Amplifier 4 x 150 W VP-3154, Power Amplifier 4 x 300 W VP-3304, and Power Amplifier 4 x 500 W VP-3504 .....	13-12
<b>2. SPECIFICATIONS .....</b>	<b>13-13</b>
2.1. Fireman's Microphone RM-200XF .....	13-13
2.2. Remote Microphone RM-200X .....	13-14
2.3. Remote Microphone Extension RM-210 .....	13-15
2.4. System Manager VX-2000 .....	13-16
2.5. Voice Announcement Board EV-200M .....	13-17
2.6. Remote Microphone Input Module VX-200XR .....	13-17
2.7. Audio Input Module with Control Input VX-200XI .....	13-18
2.8. Surveillance Frame VX-2000SF .....	13-19
2.9. Pilot Tone Detection Module VX-200SP .....	13-20
2.10. Impedance Detection Module VX-200SZ .....	13-21
2.11. Equaliser Card VX-200SE .....	13-22
2.12. Control Input Module VX-200SI .....	13-22
2.13. Control Output Module VX-200SO .....	13-22
2.14. Power Amplifier 4 x 60 W VP-2064 .....	13-23
2.15. Power Amplifier 2 x 120 W VP-2122 .....	13-24
2.16. Power Amplifier 1 x 240 W VP-2241 .....	13-25
2.17. Power Amplifier 1 x 420 W VP-2421 .....	13-26
2.18. Digital Power Amplifier 4 x 150 W VP-3154 .....	13-27
2.19. Digital Power Amplifier 4 x 300 W VP-3304 .....	13-28
2.20. Digital Power Amplifier 4 x 500 W VP-3504 .....	13-29
2.21. Power Amplifier Input Module VP-200VX .....	13-30
2.22. Wall Mounting Bracket WB-RM200 .....	13-30

## SAFETY PRECAUTIONS

- Be sure to read the instructions in this section carefully before use.
- Make sure to observe the instructions in this manual as the conventions of safety symbols and messages regarded as very important precautions are included.
- We also recommend you keep this instruction manual handy for future reference.

### Safety Symbol and Message Conventions

Safety symbols and messages described below are used in this manual to prevent bodily injury and property damage which could result from mishandling. Before operating your product, read this manual first and understand the safety symbols and messages so you are thoroughly aware of the potential safety hazards.



## WARNING

Indicates a potentially hazardous situation which, if mishandled, could result in death or serious personal injury.

#### [All units]

- To prevent a fire or electric shock, never open nor remove the unit case as there are high voltage components inside the unit. Refer all servicing to your nearest TOA dealer.
- Do not place cups, bowls, or other containers of liquid or metallic objects on top of the unit. If they accidentally spill into the unit, this may cause a fire or electric shock.

#### [RM-200XF, RM-200X, RM-210 only]

- Avoid installing or mounting the unit in unstable locations, such as on a rickety table or a slanted surface. Doing so may result in the unit falling down and causing personal injury and/or property damage.
- Install the unit only in a location that can structurally support the weight of the unit and the mounting bracket. Doing otherwise may result in the unit falling down and causing personal injury and/or property damage.

#### [VX-2000DS, VX-3000DS, VX-200PS only]

- Do not expose the unit to rain or an environment where it may be splashed by water or other liquids, as doing so may result in fire or electric shock.
- Use the unit only with the voltage specified on the unit. Using a voltage higher than that which is specified may result in fire or electric shock.
- Do not cut, kink, otherwise damage nor modify the power supply cord. In addition, avoid using the power cord in close proximity to heaters, and never place heavy objects -- including the unit itself -- on the power cord, as doing so may result in fire or electric shock.
- Should the following irregularity be found during use, immediately switch off the power, disconnect the power supply plug from the AC outlet and contact your nearest TOA dealer. Make no further attempt to operate the unit in this condition as this may cause fire or electric shock.
  - If you detect smoke or a strange smell coming from the unit.
  - If water or any metallic object gets into the unit
  - If the unit falls, or the unit case breaks
  - If the power supply cord is damaged (exposure of the core, disconnection, etc.)
  - If it is malfunctioning (no tone sounds.)
- Do not insert nor drop metallic objects or flammable materials into the unit, as this may result in fire or electric shock.
- Do not touch a plug during thunder and lightning, as this may result in electric shock.

#### [VX-2000DS, VX-3000DS only]

- To avoid electric shock, disconnect both the AC plug and battery terminals before performing component installation or service.

#### [VX-200SP, VX-200SZ, VP-2000 series amplifiers, VP-3000 series amplifiers only]

- Components or parts having the symbol "⚡" are live and dangerous. Refer connections of these terminals to a professional electrical contractor to avoid electric shocks.

#### [VX-2000SF, VP-2000 series amplifiers, VP-3000 series amplifiers only]

- Do not insert nor drop metallic objects or flammable materials into the unit, as this may result in fire or electric shock.



## **CAUTION**

Indicates a potentially hazardous situation which, if mishandled, could result in moderate or minor personal injury, and/or property damage.

### **[All units]**

- Avoid installing the unit in humid or dusty locations, in locations exposed to the direct sunlight, near the heaters, or in locations generating sooty smoke or steam as doing otherwise may result in fire or electric shock.
- Note correct polarity (positive and negative orientation) when connecting the power supply cord. Reversed polarity connections will cause damage to the amplifier or car.
- Install the unit only in stable locations, and make appropriate arrangements to prevent it from falling down or rolling across the floor. If it falls down or moves, this may cause personal injury and/or property damage.
- Use the dedicated AC adapter or DC power supply unit for the unit. Note that the use of other adapter may cause a fire.
- Have the unit checked periodically by the shop from where it was purchased. Failure to do so may result in corrosion or damage to the unit that could cause the unit to fall, possibly causing personal injury.

### **[VX-2000DS, VX-3000DS only]**

- Never plug in nor remove the power supply plug with wet hands, as doing so may cause electric shock.
- When unplugging the power supply cord, be sure to grasp the power supply plug; never pull on the cord itself. Operating the unit with a damaged power supply cord may cause a fire or electric shock.
- Do not block the ventilation slots in the unit's cover. Doing so may cause heat to build up inside the unit and result in fire.
- Contact your TOA dealer as to the cleaning. If dust is allowed to accumulate in the unit over a long period of time, a fire or damage to the unit may result.
- Make sure to observe the following handling precautions so that a fire or personal injury does not result from explosion of the battery.
  - Do not short, disassemble, heat nor put the battery into a fire.
  - Avoid using both new and old batteries together.
  - Do not solder a battery directly.
  - Be sure to use the specified type of batteries.
  - Note correct polarity (positive and negative orientation) when inserting a battery in the unit.
  - Avoid locations exposed to the direct sunlight, high temperature and high humidity when storing batteries.

### **[VX-200PS only]**

- Never plug in nor remove the power supply plug with wet hands, as doing so may cause electric shock.
- When unplugging the power supply cord, be sure to grasp the power supply plug; never pull on the cord itself. Operating the unit with a damaged power supply cord may cause a fire or electric shock.
- Do not block the ventilation slots in the unit's cover. Doing so may cause heat to build up inside the unit and result in fire.
- Contact your TOA dealer as to the cleaning. If dust is allowed to accumulate in the unit over a long period of time, a fire or damage to the unit may result.

### **[VX-2000SF only]**

- Do not block the ventilation slots in the unit's cover. Doing so may cause heat to build up inside the unit and result in fire.

### **[VP-2000 series amplifiers, VP-3000 series amplifiers only]**

- Do not block the ventilation slots in the unit's cover. Doing so may cause heat to build up inside the unit and result in fire.
- Do not operate the unit for an extended period of time with the sound distorting. This is an indication of a malfunction, which in turn can cause heat to generate and result in a fire.
- Contact your TOA dealer as to the cleaning. If dust is allowed to accumulate in the unit over a long period of time, a fire or damage to the unit may result.

# ***Chapter 1***

---

***NOTE***

## 1. GENERAL DESCRIPTION

The TOA VX-2000 Series broadcast system is designed for both general and emergency purpose broadcasts. It is comprised of the System Manager, Surveillance Frame, Power Amplifiers, Power Supply unit, Emergency Power Supply, and a user-specified number of Remote Microphones. The system complies with the EN60849 Standard and its failure detection circuitry operates continuously to check components and speaker lines for any irregularities. If detected, failure warnings are provided by way of an LED indicator and a buzzer.

## 2. SYSTEM FEATURES

### **Modular System Offers Connection to Various Sound Sources.**

The VX-2000 System Manager features 8 input slots that permit the use of various input sources with the selection of corresponding modules.

### **Up to 8 Remote Microphones Can Be Connected.**

- A total of 8 RM-200X and RM-200XF Remote Microphones can be connected to the VX-2000. Up to 4 RM-200XF units can be installed.
- RM-210 extension capability permits the number of Remote Microphone function keys to be increased to up to 105 keys per unit.
- The system can be configured for up to 315 function key settings.

### **Sound Source Devices**

- Up to 2 EV-200 units can be connected to the VX-2000.
- The VX-2000 features 4 different chime sound sources.

### **Standard-Equipment Control Input and Output**

The VX-2000 features 16 control inputs and 16 control outputs as standard equipment.

### **Expansion to Up to 80 Output Zones\***

The VX-2000SF Surveillance Frame can be expanded to up to 8 units, increasing the number of available output zones to up to 80 zones.

\* Available when the label on each packing box of the VX-2000 system components (VX-2000, VX-2000SF, RM-200X, and RM-200XF) indicates "EN80," and the Setting Software Version is 3.0 or later.

### **Control Input and Output Modules, and 2 Types of Speaker Output Modules**

- The VX-2000SF is designed to accept up to 10 modules. The control input module, control output module, and 2 types of speaker output modules are available.
- Speaker output modules feature failure-detection circuitry. Two failure detection methods are provided: impedance checking and pilot signal monitoring. Such failure modes as speaker line shorts, open circuits and ground faults can be detected.
- With the addition of extra control input modules and control output modules, the number of control inputs and outputs can be expanded to up to a total of 128 terminals within the system. (16 terminals are included as standard equipment in the VX-2000.)

### **9-Band Graphic Equaliser Card**

Provides 9 bands of computer-adjustable graphic equalisation to the system's speaker output module.

### **Standby Amplifier Function**

A standby amplifier can be installed for each VX-2000SF to automatically provide substitute amplifier output should the main power amplifier fail.

### **CPU Switch**

Enables broadcast from the RM-200XF Fireman's Microphones to all output zones even if the system's main CPU fails.

### **Individual Block Failure Detection Circuitry**

- This failure detection function monitors cable connections between the Remote Microphones and the VX-2000, between the VX-2000 and the VX-2000SF, between the VX-2000SF and the VP power amplifiers, and between the VP power amplifiers and the speakers.
- The function detects and warns of such failure modes as blown fuses or overheating in the VP power amplifier.
- Can detect and indicate failure of the VX-2000DS' and VX-3000DS' charging circuitry, or battery irregularities.

### **Failure Indication**

- The failure LED indicators for the VX-2000, VX-2000SF and Remote Microphone light when any failure is detected within the system.
- The failure indication function can be assigned to the Remote Microphone. When assigned, the LEDs flash and a buzzer is sounded if a failure is detected.

### **Monitoring Function**

The sound output of a selected output zone can be monitored using the Remote Microphone's internal speaker or the VX-2000's monitor output.

### **Time Schedule Function**

- A weekly schedule can be programmed.
- Up to 40 specific day programs can be set for any desired date and time.
- A summertime period can be set by either the system's PC software or the VX-2000's Summertime Setting switch.

### **Energy Saving Mode**

Battery consumption can be reduced by using the VP power amplifier's standby function (since the entire system's power consumption is reduced by putting unnecessary power amplifiers in standby mode).

### **PC Setting Software**

PC software is used to select input and output equipment, or set priorities, broadcast patterns, items to be activated, etc. Various functions can also be freely assigned to the Remote Microphone's function keys.

### **PC Software Provides Versatile Auxiliary Operation**

- The VX-2000's memory can log up to 2,000 events, which can be read into a PC.
- System block diagrams and individual equipment settings can be printed out using the VX-2000's PC software.
- Remote Microphone function key names can be printed out and used as name labels.
- System configurations and connections can be checked during equipment installation.
- Inspection mode permits inspection of emergency broadcast equipment operations without actually making broadcasts.

### 3. HANDLING PRECAUTIONS

- Do not install the unit in locations exposed to the direct sunlight or heaters, as the unit could be deformed or discoloured.
- Avoid installing or storing the unit in dusty or humid locations, as doing otherwise could cause the unit's failure.
- Keep a unit as far away as possible from a fluorescent lamp, digital equipment, PC or other equipment which generate high frequency noise.

#### **[VX-2000, VX-2000SF, VP-2000 series amplifiers, VX-2000DS, VX-2000PF]**

- These units are designed exclusively for rack mount use. If 2 or more units are mounted in an equipment rack, space should be provided upper and lower side of the units for ventilation. The perforated panel is recommended in place of space. For rack mounting, refer to [p. 8-44](#).

#### **[VX-2000, VX-2000SF, VP-2000 series amplifiers, VP-3000 series amplifiers]**

- To prevent noise oscillation, keep input and output cables as far away from each other as possible.

#### **[VX-2000, VX-2000SF, VP-2000 series amplifiers, VP-3000 series amplifiers VX-2000DS, VX-3000DS]**

- Hum noise may be generated if ground loops are created. This noise can be minimized by connecting each component's rear panel ground terminal to earth.

#### **[VP-2000 series amplifiers, VP-3000 series amplifiers]**

- Avoid parallel amplifier connections, which could result in amplifier failure.

#### **[VX-2000DS, VX-3000DS, VX-200PS]**

- Each unit is a permanent connected apparatus having no power on/off switch on itself. Its power cord should be connected to the AC power outlet of the junction panel, so that you can control the power on/off for each unit. For the power line of the rack system, ALL-Pole Mains Switch with a contact separation of at least 3 mm in each pole should be incorporated in the electrical installation of the building.

#### **[VX-200XR/200XI/200SZ/200SP/200SI/200SO, 900 modules]**

- Because each unit is not "hot-pluggable," the system needs to be shut down when it is installed or removed. For turning the system power off, refer to the Instruction Manual attached to the VX-2000DS or VX-3000DS.

#### **[VP-2000 series amplifiers, VP-3000 series amplifiers, VX-2000DS, VX-3000DS]**

- The VP-2000 series amplifiers can be used in conjunction with the VX-2000DS or VX-3000DS while the VP-3000 series amplifiers can be used in conjunction with the VX-3000DS only, not with the VX-2000DS.



# ***Chapter 2***

---

## ***PRODUCT DESCRIPTIONS***

# 1. MAXIMUM SYSTEM EXAMPLE

## 1.1. Block Diagram

The following block diagram shows the maximum size system that can be assembled with the VX-2000 Series.

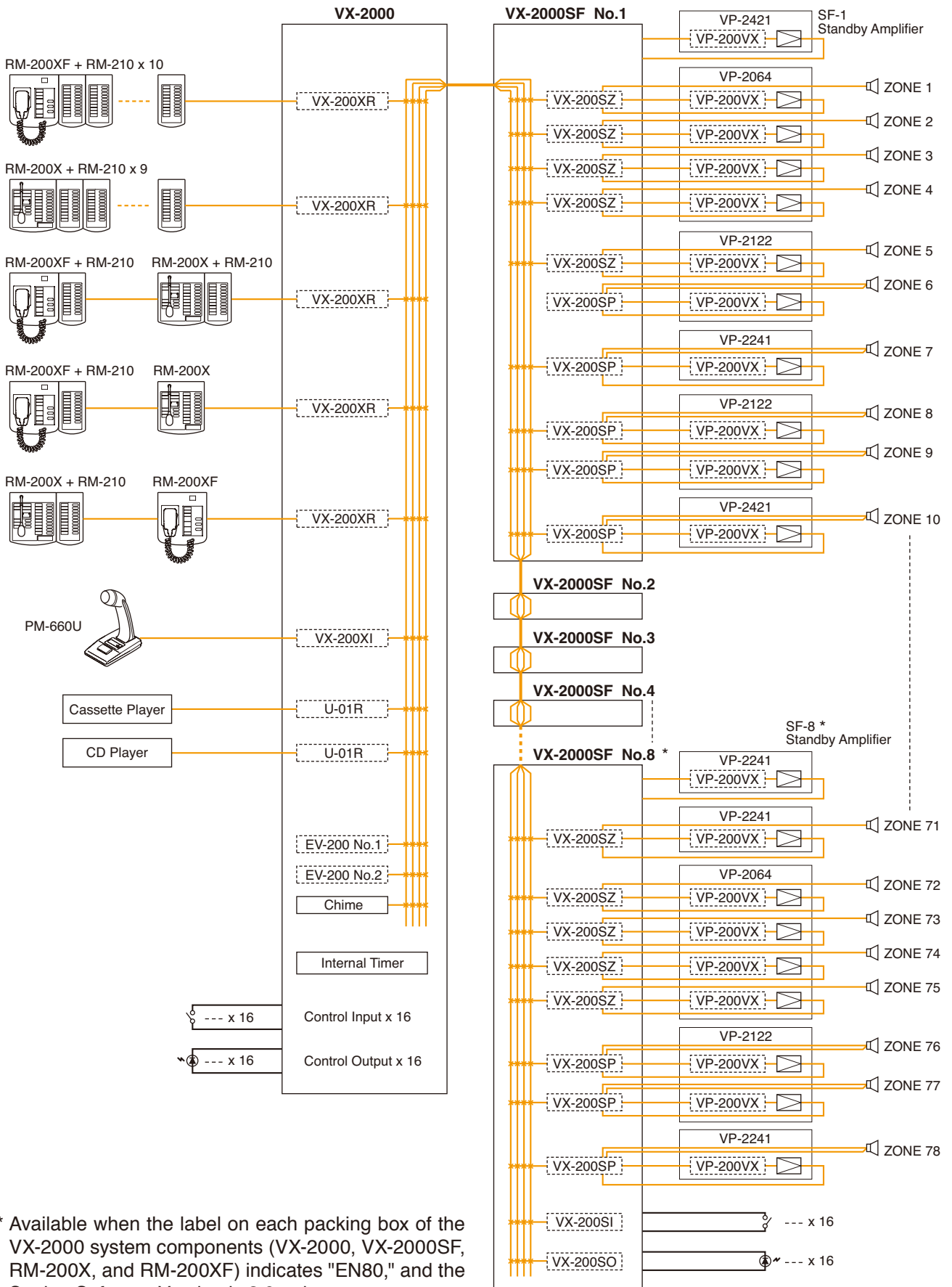

\* Available when the label on each packing box of the VX-2000 system components (VX-2000, VX-2000SF, RM-200X, and RM-200XF) indicates "EN80," and the Setting Software Version is 3.0 or later.

## 1.2. Maximum System Configuration Table

Component	Maximum No. of Units			
<b>Input Source Equipment</b>				
RM-200XF	4 units	4 units in total of Emergency-set models	8 units in total of both models	18 units in total of all Input Source Equipment
RM-200X	4 units ("Emergency" type) 8 units ("General" type)			
Paging Microphone and Music Sources (Cassette, CD, etc.)	8 units			
EV-200	2 units			
Chime (internal)	1 unit			
<b>RM-200XF's and RM-200X's Function Key Extension</b>				
RM-210	10 units (115 function keys) per RM-200XF 9 units (115 function keys) per RM-200X	315 function keys per system		
<b>VX-2000</b>				
VX-2000	1 unit			
<b>Input Module (to be installed in VX-2000)</b>				
VX-200XR VX-200XI 900 module	8 units in total of all Input Modules Usable 900 modules: M-01F, M-01M, M-01P, M-01S, M-01T, M-03P, M-51F, M-51S, M-51T, M-61F, M-61S, M-61T, U-01F, U-01P, U-01R, U-01S, U-01T, U-03R, U-03S, U-61S, and U-61T			
<b>VX-2000SF</b>				
VX-2000SF	8 units*			
<b>SF Module (to be installed in VX-2000SF)</b>				
VX-200SP, VX-200SP-2	80 units	80 units in total of all SF Modules (10 units per VX-2000SF)		
VX-200SZ, VX-200SZ-2	80 units			
VX-200SI	7 units			
VX-200SO	7 units			
<b>Optional Equaliser Card (to be installed in VX-200SP, VX-200SP-2, VX-200SZ and VX-200SZ-2)</b>				
VX-200SE	80 units			
<b>Control Input</b>				
VX-2000	16 inputs (as standard equipment)	128 inputs in total		
VX-200SI	112 inputs (7 units)			
<b>Control Output</b>				
VX-2000	16 outputs (as standard equipment)	128 outputs in total		
VX-200SO	112 outputs (7 units)			
<b>Power Amplifier</b>				
<b>Note:</b> The number and type of power amplifiers should be determined depending on the required speaker output for each zone.				
VP-2064 (4 ch) VP-2122 (2 ch) VP-2241 (1 ch) VP-2421 (1 ch)	80 channels* (80 zones)*			
Standby Amplifier	8 channels* (1 channel per VX-2000SF)			
<b>Power Amplifier Input Module</b>				
VP-200VX	88 units* in total of modules installed in Power and Standby Amplifiers			
<b>Power Supply</b>				
<b>Note:</b> Necessary power capacity should be calculated based on total system specifications.				
VX-2000DS	16 units*	2 units per VX-2000SF		
VX-200PS	48 units*	3 units per VX-2000DS		
Battery	32 or 64 units*	2 or 4 units per VX-2000DS		

\* Available when the label on each packing box of the VX-2000 system components (VX-2000, VX-2000SF, RM-200X, and RM-200XF) indicates "EN80," and the Setting Software Version is 3.0 or later.

## 2. NOMENCLATURE AND FUNCTIONS

### 2.1. Fireman's Microphone RM-200XF

- Specially designed for both emergency and general purpose broadcast applications, the Fireman's Microphone can be used for push-button zone selection and microphone broadcasts.
- PC-programmable system software permits desired functions to be assigned to individual Function keys (equipped with 2 LED indicators).
- Up to 10 RM-210 Remote Microphone Extension units can be used with each RM-200XF Remote Microphone.
- Up to 4 RM-200XF Fireman's Microphones can be connected within a system.
- The CPU switch enables all-zone emergency broadcasts from the RM-200XF Fireman's Microphone, even when the CPU malfunctions.
- Failures of Emergency buttons and signal (both control and audio) path between the microphone (including the internal microphone element) and the VX-2000 System Manager are automatically detected.

[Top]

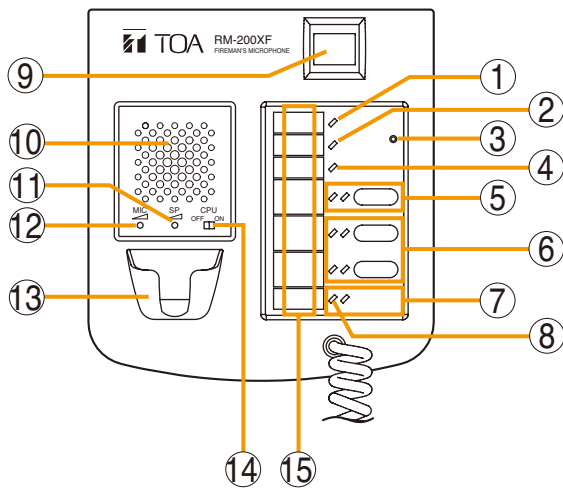

[Side]

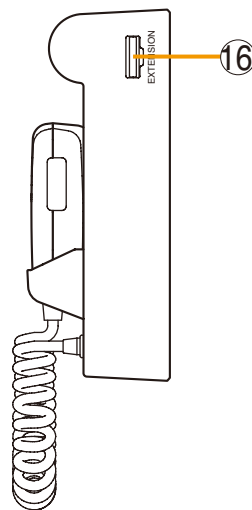

[Bottom]

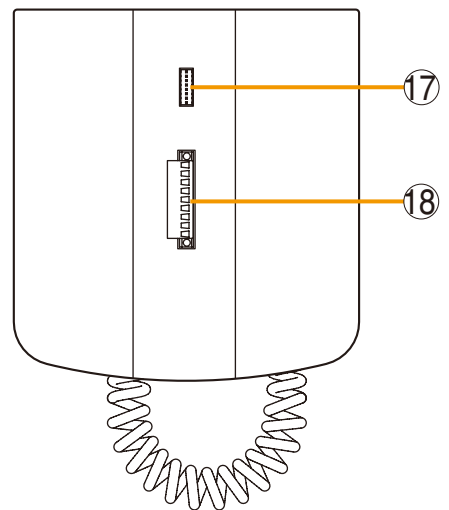

#### [Hand-held microphone]

(Unidirectional type)

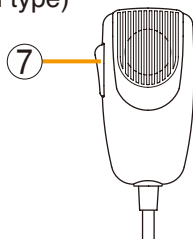

#### 1. Power indicator

Lights green to indicate that the unit is powered and operational.

Extinguishes when no power is supplied or power voltage drops below the operational level.

#### 2. Failure indicator

Indicates system operating status.

- Off: Normal
- Lights yellow: System failure detected
- Flashes yellow: Communications error detected between VX-2000 and RM-200XF
- Lights or flashes green: RM-200XF CPU failure detected

#### 3. Service switch

Used only for service maintenance and for returning the unit operation to a password entry status (only when a password is set). Do not touch this switch for other purposes.

Refer to [p. 7-23](#) for password setting and [p. 5-2](#) for bringing the unit into password entry status.

#### 4. CPU indicator (Red)

Extinguishes when the CPU switch is set to ON.

Lights red when the CPU switch of any RM-200XF unit in the system is set to OFF.

#### 5. Function key 2

(with red, green, or orange LED indicators)

Various functions can be assigned to this key using the PC system setting software.

Refer to [p. 7-54](#) for the assignable functions.

This key can be disabled by the DIP switch No. 17 setting, functioning as an indicator. For details, refer to [p. 8-5](#).

**6. Function keys****(with red, green, or orange LED indicators)**

Various functions can be assigned to these keys using the PC system setting software.

Refer to [p. 7-54](#) for the assignable functions.

**7. Talk key****(with red, green, or orange LED indicators)**

The microphone's talk key function as well as other functions can be assigned to this button using the PC system setting software. Refer to [p. 7-54](#) for the assignable functions.

**8. Microphone sensitivity adjustment indicator**

When the Setting switch (No.17) is set to "Level meter mode: ON," this LED functions as a microphone sensitivity adjustment indicator for the Hand-held Microphone during microphone broadcasts. Otherwise, this LED provides normal indication (depending on the function assigned to the Function key).

Refer to [p. 8-4](#) for the instructions on microphone sensitivity adjustment.

**9. Emergency button**

Such functions as Emergency activation, Emergency reset, and Emergency message recall can be assigned to this button using the PC system setting software.

When the Emergency activation from the RM-200XF is not desired, the Emergency button can be made disabled by the DIP switch No.17 setting, functioning only as an indicator to show emergency mode.

For the setting, refer to [p. 8-5](#).

For the assignable functions, refer to [p. 7-54](#).

**10. Monitor speaker**

Used to monitor current broadcasts.

**11. Monitor speaker output volume control [SP]**

Adjusts the monitor speaker's output volume level.

**12. Microphone volume control [MIC]**

Adjusts the input sensitivity of the Hand-held Microphone.

**13. Microphone hanger**

Used to hold the unit's Hand-held Microphone.

**14. CPU switch [CPU ON/OFF]**

This switch is set to the ON position during normal operation.

**Note**

Setting this switch to the OFF position interrupts all current emergency and general-purpose broadcasts regardless of CPU operations, permitting all-zone broadcasts to be made from the RM-200XF Fireman's Microphone.

For details, refer to [p. 3-9](#).

**15. Name labels**

Enter the zone names and functions assigned to Function keys (equipped with 2 LEDs) on these labels. The PC system software's Print function permits formatted name and function labels to be printed out from a connected printer.

**16. RM-210 extension connector [EXTENSION]**

An RM-210 Extension unit can be attached to this connector to increase the number of available Function keys.

**17. Setting DIP switch**

Used to set the following functions.

- Unit ID No. setting (necessary when 2 or more Remote Microphones are connected.)
- Level meter mode ON/OFF
- Compression ON/OFF
- Emergency Button Enable/Disable
- Function key 2 Enable/Disable

Refer to [p. 8-2](#) for the DIP switch settings.

**18. Link connector [LINK]****(Plug-in, screw type connector)**

Connects to the VX-200XR Remote Microphone Input modules mounted in the VX-2000 System Manager. When cascading 2 or more RM-200X and RM-200XF units, connect their Link connectors to each other.

Signals to be connected are as follow:

- **Audio monitor line [MONITOR IN H/C]**  
A signal line for monitoring current broadcast status
- **Communication line [RM DATA]**  
A LONWORKS\* communication line
- **Audio output line [AUDIO OUT H/C]**  
Audio output from the microphone
- **Power supply [DC POWER IN +/-]**  
Supplies power from the VX-2000 main system
- **Shield [SHIELD]**  
Wire shielding

\* LONWORKS is a trademark of Echelon Corporation.

**[Resetting the RM-200XF]**

The RM-200XF can be returned to the status it was in at the time of system power-on through the operation below.

Hold down the Function key 4 for about 2 seconds while pressing the service switch with a pointed object. Then, the Failure indicator will light red.

After a while, the RM-200XF will be in the normal operating status.

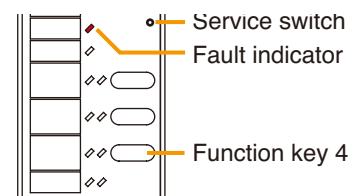

## 2.2. Remote Microphone RM-200X

- Designed for both emergency and general purpose broadcast applications, the Remote Microphone can be used for zone selection and microphone broadcasts. It can also be set for use only in general purpose applications.
- PC-programmable system software permits desired functions to be assigned to individual Function keys (equipped with 2 LED indicators).
- Up to 9 RM-210 Remote Microphone Extension units can be used with each RM-200X Remote Microphone.
- Up to 8 in total of RM-200X and RM-200XF units can be connected within a system.

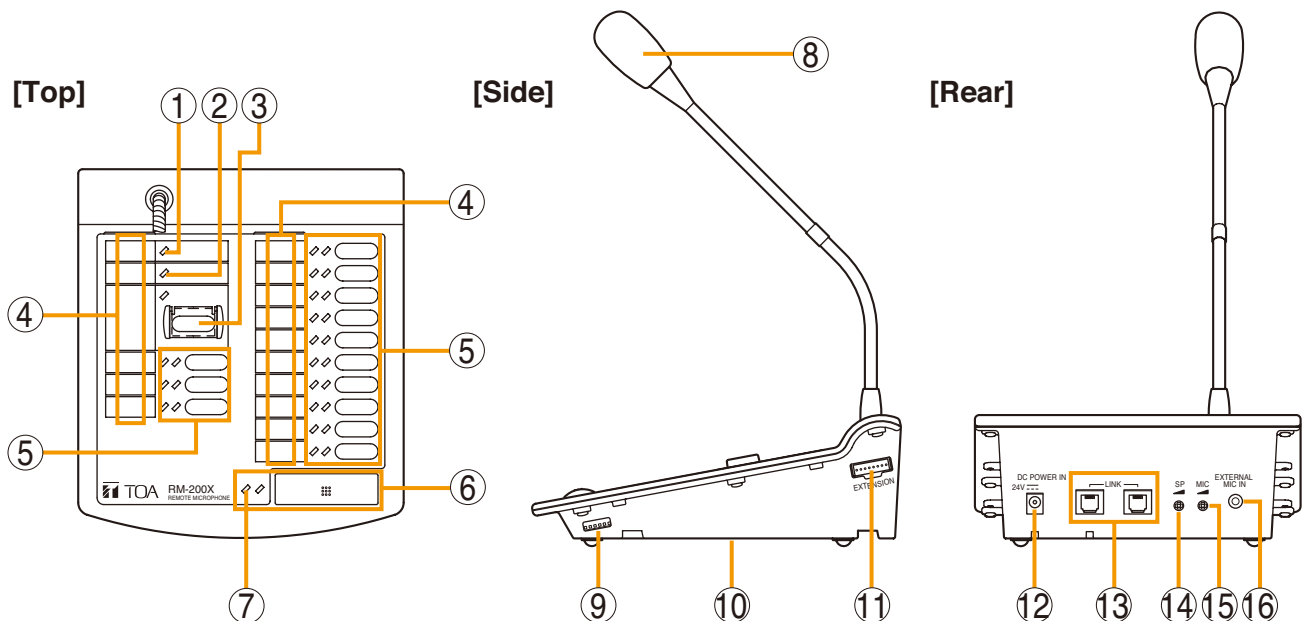

### 1. Power indicator

Lights green to indicate that the unit is powered and operational.

Extinguishes in the following conditions:

- When no power is supplied.
- When power voltage drops below the operational level.
- With the Remote Microphone designated as general type, when Emergency mode is activated.

### 2. Failure indicator

Indicates system operating status.

- Off: Normal
- Lights yellow: System failure detected
- Flashes yellow: Communications error detected between VX-2000 and RM-200X
- Lights or flashes green: RM-200X CPU failure detected
- Lights red: RM-200XF CPU switch OFF

### 3. Emergency button

Such functions as Emergency activation, Emergency reset, and Emergency message recall can be assigned to this button using the PC system setting software.

Refer to [p. 7-54](#) for the assignable functions.

### 4. Name labels

Enter the zone names and functions assigned to Function keys (equipped with 2 LEDs) on these labels. The PC system software's Print function permits formatted name and function labels to be printed out from a connected printer.

### 5. Function key (with red, green or orange LED indicators)

Various functions can be assigned to these keys using the PC system setting software.

Refer to [p. 7-54](#) for the assignable functions.

### 6. Talk key (with red, green, or orange LED indicators)

The microphone's talk key function as well as other functions can be assigned to this key using the PC system setting software. Refer to [p. 7-54](#) for the assignable functions.

**7. Microphone sensitivity adjustment indicator**

When the Setting DIP switch (No.9) is set to "Level meter mode: ON," this LED functions as a microphone sensitivity adjustment indicator for the Gooseneck microphone (No.8) or external microphone (No.16) during microphone broadcasts. Otherwise, this LED provides normal indication (depending on the function assigned to the Function key).

Refer to p. 8-4 for the instructions on microphone sensitivity adjustment.

**8. Gooseneck microphone**

This easily positioned unidirectional microphone offers easy use and clear sound output.

**9. Setting DIP switch**

Used to set the following functions.

- Unit ID No. setting (necessary when 2 or more Remote Microphones are connected.)
- Level meter mode ON/OFF
- Compression ON/OFF

Refer to p. 8-2 for the DIP switch settings.

**10. Monitor speaker**

Used to monitor current broadcasts.

**11. RM-210 extension connector [EXTENSION]**

An RM-210 Extension unit can be attached to this connector to increase the number of available Function keys.

**12. DC power input jack [DC POWER IN]**

When using the RM-200X only for general-purpose applications, the power can be supplied from the AC adapter.

**13. Link connectors [LINK]**

These RJ45 connectors connect to the VX-200XR Remote Microphone Input Module mounted in the VX-2000 System Manager. When cascading 2 or more RM-200X and RM-200XF units, connect their Link connectors to each other.

**14. Monitor speaker output volume control [SP]**

Adjusts the volume level of the monitor speaker (No.10) located at the bottom.

**15. Microphone volume control [MIC]**

Adjusts the input sensitivity of the Gooseneck microphone or connected external microphone.

**16. External microphone input jack [EXTERNAL MIC IN]**

This 3.5 mm-diameter mini-phone jack connects to a headset or other external condenser microphone.

**Note**

The Gooseneck microphone (No.8) is disabled while this jack is in use.

**[Resetting the RM-200X]**

The RM-200X can be returned to the status it was in at the time of system power-on through the operation below.

Simultaneously holding down the Function keys 4, 6, and 7 for about 2 seconds causes the Failure indicator to light red.

After a while, the RM-200X will be in the normal operating status.

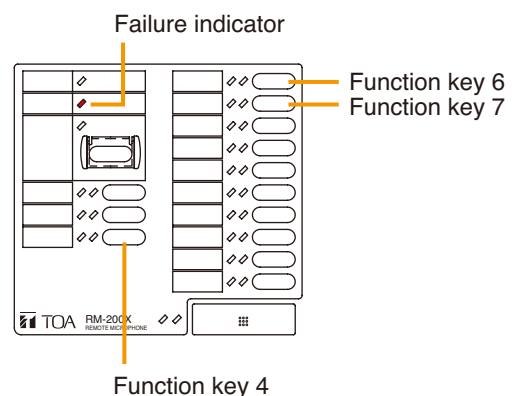

## 2.3. Remote Microphone Extension RM-210

Each connected RM-210 Extension unit adds 10 Function keys to the base RM-200X or RM-200XF.

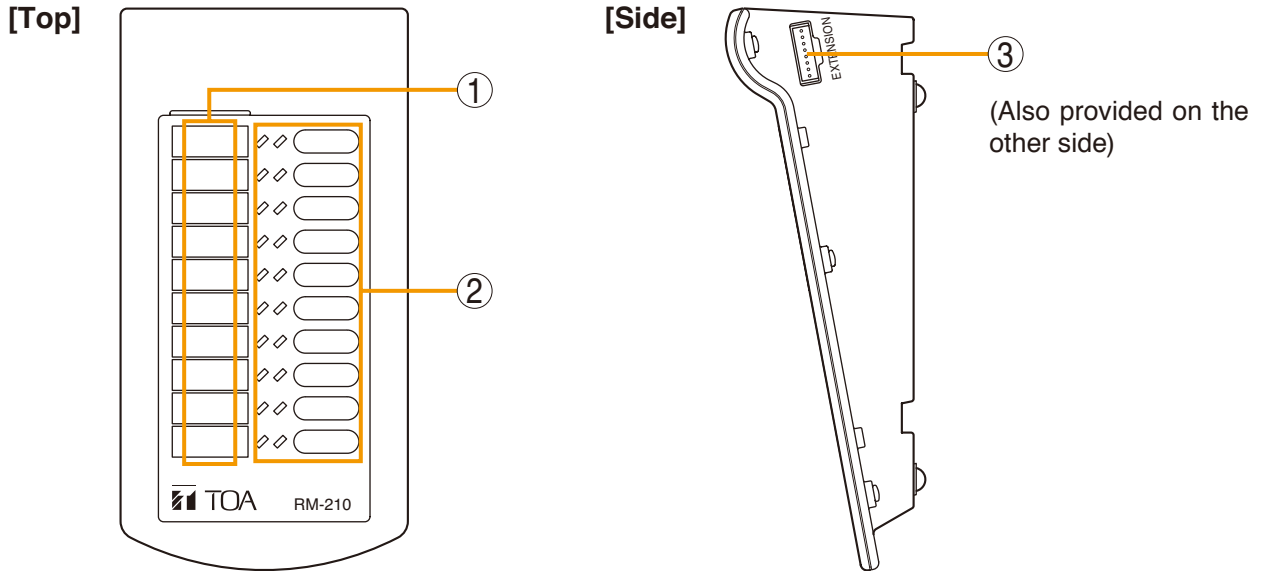

### 1. Name labels

Enter the zone names and functions assigned to the function keys (equipped with 2 LEDs) on these labels. The PC system software's Print function permits formatted name and function labels to be printed out from a connected printer.

### 2. Function keys (with red, green, or orange LED indicators)

Various functions can be assigned to these keys using the PC system setting software. Refer to [p. 7-54](#) for the assignable functions.

### 3. Extension connector [EXTENSION]

Used to further increase the number of Function keys. Up to 9 RM-210 units can be connected to an RM-200X or up to 10 units can be connected to an RM-200XF using this connector, providing the base Remote Microphone with a maximum total of 105 Function keys. The entire system can have a maximum total of up to 315 Function keys.



## 2.4. System Manager VX-2000

- The VX-2000 System Manager is the central matrix section that assigns input signals to 4 audio buses, and controls the entire system.
- The Remote Microphones and other sound source components are connected to the input modules mounted in the VX-2000. The usable modules include the VX-200XR Remote Microphone Input Module, the VX-200XI Audio Input Module (with Control Input), and the range of 900 Series modules (M-01F, M-01M, M-01P, M-01S, M-01T, M-03P, M-51F, M-51S, M-51T, M-61F, M-61S, M-61T, U-01F, U-01P, U-01R, U-01S, U-01T, U-03R, U-03S, U-61S, and U-61T).
- Up to 2 EV-200 Voice Announcement Boards can be installed.
- Equipped with an internal chime source.
- 16 external control inputs and 16 external control outputs are provided as standard equipment.

### [Front]

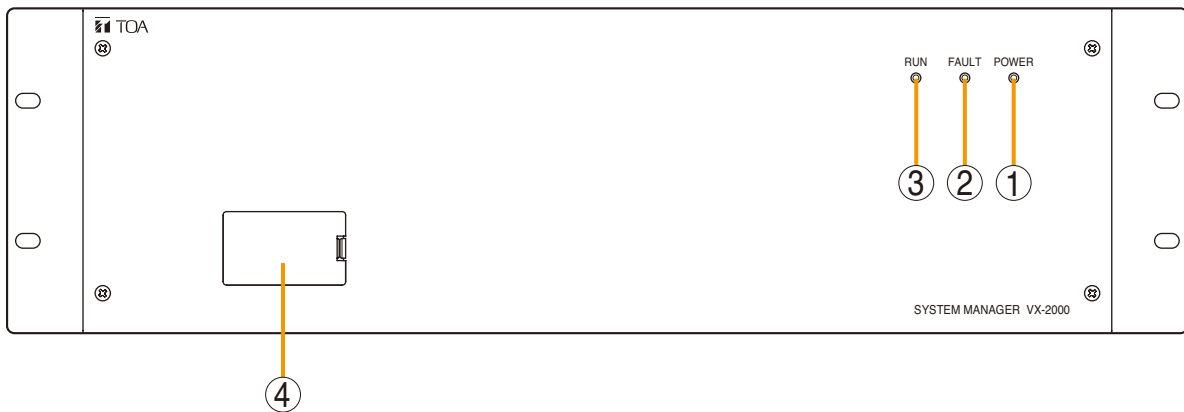

### [Front panel detached]

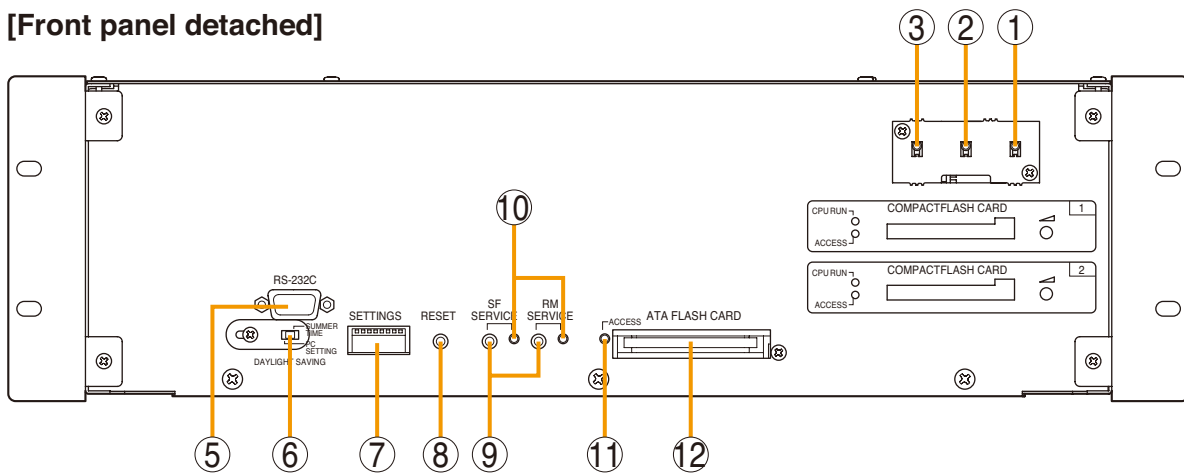

### [Rear]

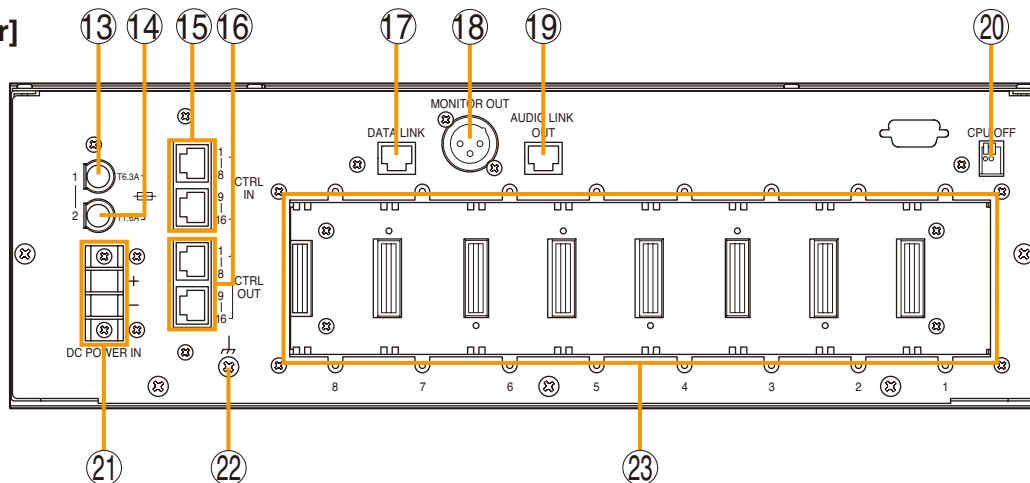

1. **Power indicator [POWER]**  
Lights green when the power is supplied.
2. **Failure indicator [FAULT]**  
Lights yellow when a failure is detected in the system.
3. **Run indicator [RUN]**  
Lights green during correct operation.
4. **Front pocket**  
Opening the cover permits PC connections and summer time settings.
5. **RS-232C connector [RS-232C]**  
Provides connection to an external PC. Data set using the system's PC software can be downloaded or error and event logs can be read out. This connector can also be moved to the rear panel. For the instructions on moving the connector, refer to [p. 8-16](#).
6. **Daylight saving switch [DAYLIGHT SAVING]**  
Used to set the internal clock to summer time. The setting can be performed either from the VX-2000 itself or by way of the PC system software. For details, refer to [p. 7-62](#).
  - SUMMER TIME position  
Advances the internal clock and timer by 1 hour.
  - PC SETTING position  
Resets the internal timer to local standard time.
7. **Setting DIP switch [SETTINGS]**  
All switches are set to the OFF position at the factory, and should remain in this position during normal use. Do not touch unless necessary. Refer to [p. 8-23](#) for the switch settings.
8. **Reset key [RESET]**  
Restores the unit to the same condition as results when the VX-2000's power is turned OFF and ON again.  
**Note:** Pressing the Reset key resets the volume to the initial level.
9. **Service switch [SF SERVICE, RM SERVICE]**  
Used only for service maintenance. Do not touch this switch during normal system operations.
10. **Service indicator**  
Lights or flashes green if the VX-2000's CPU fails for any reason.
11. **PC card indicator [ACCESS]**  
Lights green while reading data after the PC card is accessed.
12. **Firmware update PC card slot [ATA FLASH CARD]**  
The PC memory card used to update the VX-2000's firmware is inserted into this slot.
13. **Fuse holder [FUSE]**  
Contains the DC fuse for the RM-200XF and RM-200X. Use only fuses with a rating of 250 V, T6.3 A.
14. **Fuse holder [FUSE]**  
Contains the DC fuse for the VX-2000. Use only fuses with a rating of 250 V, T1.6 A.
15. **Control input connectors [CTRL IN 1 – 8, 9 – 16]**  
These RJ45 connectors receive activation signals from external equipment to enable external VX-2000 system control. A built-in photocoupler permits internal modification for insulation. For the modification instructions, refer to [p. 8-17](#).
16. **Control output connectors [CTRL OUT 1 – 8, 9 – 16]**  
These RJ45 connectors permit the VX-2000 to control other connected external equipment. A built-in photocoupler permits internal modification for insulation. For the modification instructions, refer to [p. 8-17](#).
17. **Data link connector [DATA LINK]**  
This RJ45 connector connects to the VX-2000SF Surveillance Frame's Data Link connector. It mixes audio signals from the speaker lines connected to the monitor bus of the VX-2000SF, and then transmits the mixed signal to the VX-2000's Monitor output.
18. **Monitor output connector [MONITOR OUT]**  
A power amplifier and monitor speaker can be connected to this connector. Audio signals relayed to the monitor bus can then be monitored.
 

**Usable connectors**

XLR type male connector



Pin 1: Ground      Pin 2: Hot  
Pin 3: Cold
19. **Audio signal bus connector [AUDIO LINK OUT]**  
This RJ45 connector connects to the VX-2000SF Surveillance Frame's AUDIO LINK IN connector. It can be insulated by installing an insulating transformer in the unit. For the installation instructions, refer to [p. 8-18](#).
20. **CPU off output [CPU OFF]**  
Provides a make contact output when the RM-200XF's CPU switch is set to the OFF position. For details, refer to [p. 3-9](#).
21. **DC power input [DC POWER IN]**  
Connects to the DC POWER OUT terminal of the VX-2000DS or VX-3000DS Emergency Power Supply unit.
22. **Ground terminal**
23. **Module slots 1 – 8**  
Used to install the input modules to which the system's Remote Microphones or other sound source equipment are connected.

## 2.5. Voice Announcement Board EV-200

- Permits broadcast of general-purpose or emergency messages recorded on a corresponding CF card inserted into the slot.
- A maximum of 2 EV-200 boards can be installed in the VX-2000 System Manager. For the installation details, refer to [p. 8-19](#).

### Note

When using 2 EV-200 boards, the type of emergency broadcast message is determined by the slot used. Slot 1 is used exclusively for Warning messages, while Slot 2 is designated for Evacuation messages.

[Top]

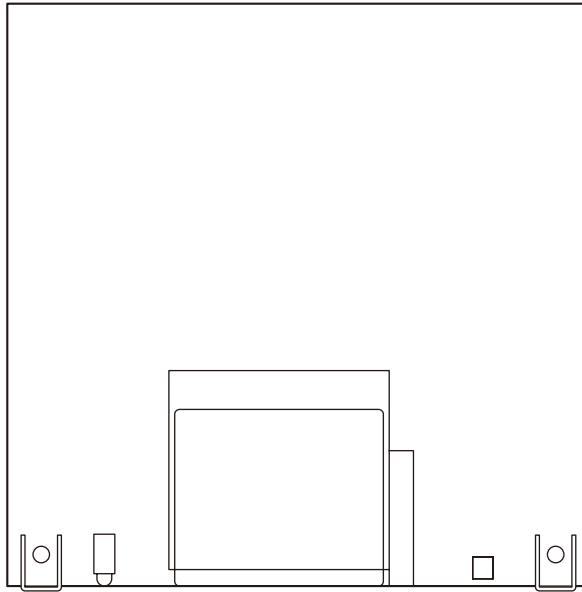

[Front]

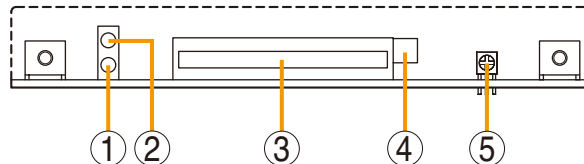

#### 1. Card access indicator [ACCESS]

Lights or flashes green when the CF card is being accessed and data is read out.

#### Note

Avoid ejecting the CF card while the Card access indicator remains lit or is flashing, as data stored in the card may be lost.

#### 2. CPU status indicator [CPU RUN]

Flashes green when the unit is operating correctly. Continuously lights or extinguishes if any irregularities are detected.

#### 3. CF card slot

Insert the recorded CF card into this slot.

#### 4. Eject button

Press this button to eject the CF card.

#### 5. Volume control

Adjusts the EV-200's output volume.

## 2.6. Remote Microphone Input Module VX-200XR

The VX-200XR module is designed to be used with the RM-200X Remote Microphone or RM-200XF Fireman's Microphone. Insert the module into the VX-2000's input module slot for each Remote or Fireman's Microphone used in the system.

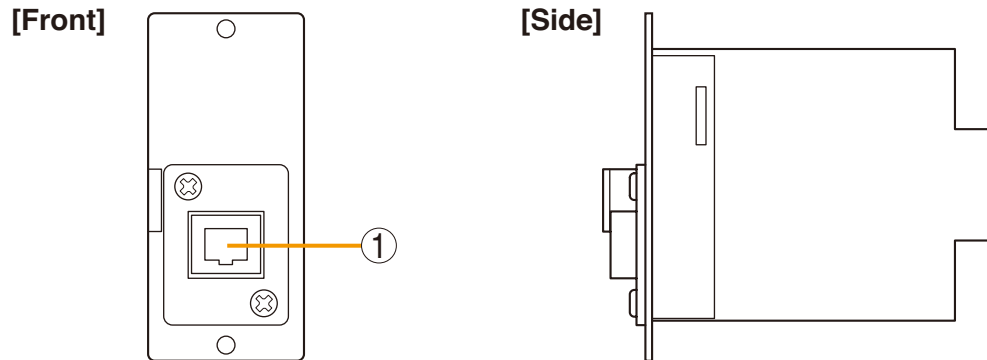

### 1. Input connector

This RJ45 connector connects to the Link connector of the RM-200X or RM-200XF Remote Microphone.

## 2.7. Audio Input Module with Control input VX-200XI

The VX-200XI module connects to TOA's Paging Microphone (example: PM-660U) or other sound source equipment with both audio and control outputs.

The audio input sensitivity can be set to either  $-70$  dB\* or  $-20$  dB\* using the internal switch.

Insert the VX-200XI module into the input module slot of the VX-2000 System Manager when designated for use.

\* 0 dB = 1 V

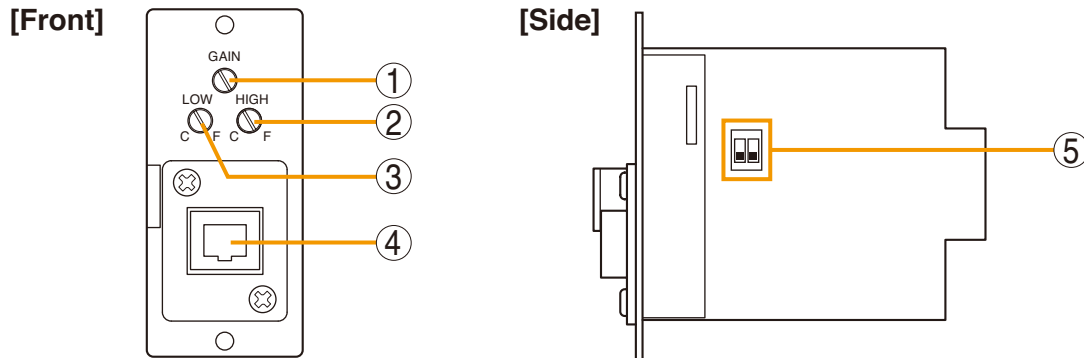

### 1. Gain control [GAIN]

Adjusts the input sensitivity level.

### 2. Treble control [HIGH]

Adjusts the input signal level in high frequencies. The control is factory-preset to "F" (Flat) position. Turning it toward "C" (Cut) position reduces high frequency elements of a signal.

### 3. Bass control [LOW]

Adjusts the input signal level in low frequencies. The control is factory-preset to "F" (Flat) position. Turning it toward "C" (Cut) position reduces low frequency elements of a signal.

### 4. Input connector

This RJ45 connector connects to the audio and control signal wiring.

Signal wires to be connected are as follows:

- 1: Control input (+)
- 2: Control input (-)
- 3: NC
- 4: Audio in (C)
- 5: Audio in (H)
- 6: NC
- 7: NC
- 8: NC

The control input terminals have a built-in photocoupler that permits internal modification for insulation. For the modification instructions, refer to [p. 8-22](#).

### 5. Setting DIP switch

Sets the input sensitivity (MIC:  $-70$  dB\* or LINE:  $-20$  dB\*) and phantom power ON/OFF.

For the settings, refer to [p. 8-21](#).

## 2.8. Surveillance Frame VX-2000SF

- The VX-2000SF Surveillance Frame is the main matrix section of the VX-2000 system that assigns audio signals to individual zones from 4 audio buses. It can be extended to up to 8 units\*.
- A total of 10 units of output modules and control modules can be installed per VX-2000SF. The following 4 types of modules can be used: the VX-200SP Pilot Tone Detection module, the VX-200SZ Impedance Detection module, the VX-200SI Control Input module, and the VX-200SO Control Output module.
- The output module features a failure detection function, and can detect failures that occur between the VX-2000 unit and the speaker lines.
- One standby amplifier can be connected per VX-2000SF. Should the power amplifier fail, output is automatically switched to the standby amplifier.
- The output volume to the power amplifier can be set using the PC system software.

\* Available when the label on each packing box of the VX-2000 system components (VX-2000, VX-2000SF, RM-200X, and RM-200XF) indicates "EN80," and the Setting Software Version is 3.0 or later.

### [Front]



### [Front panel detached]

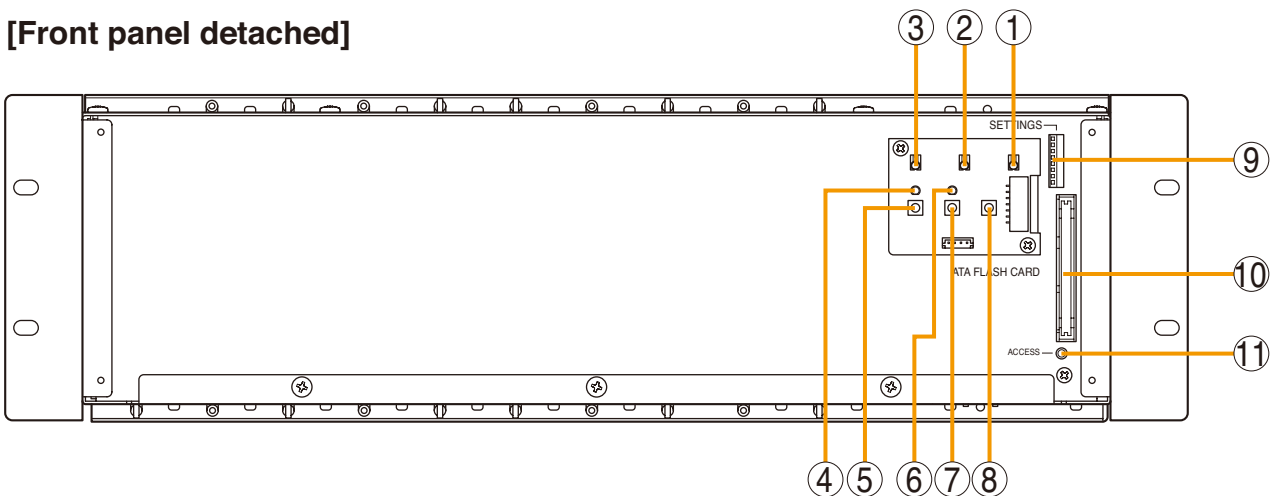

### [Rear]

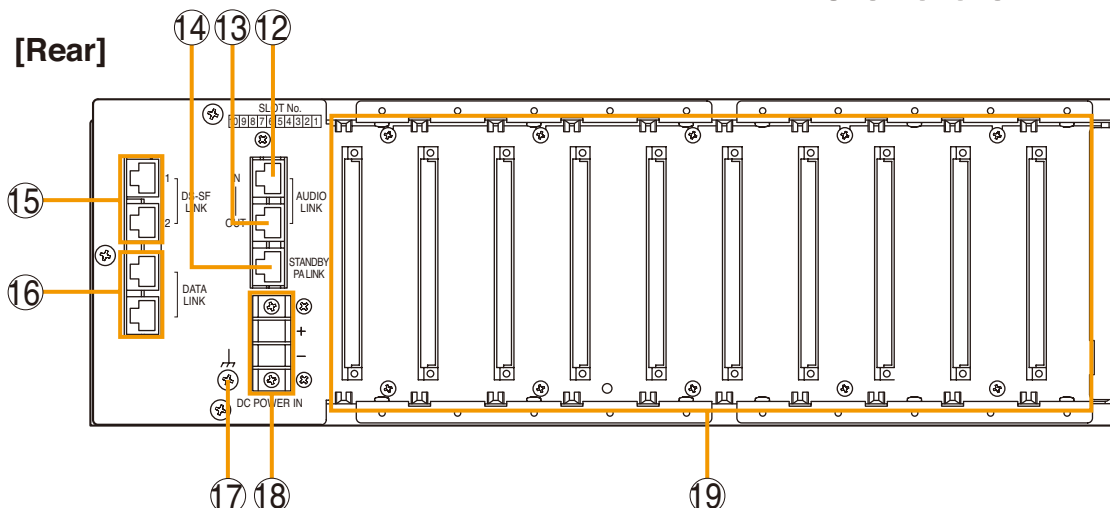

- 1. Power indicator [POWER]**  
Lights green when power is supplied.
- 2. Failure indicator [FAULT]**  
Lights yellow when a failure is detected in the system.
- 3. Run indicator [RUN]**  
Lights green when the unit is operating correctly.
- 4. Service indicator**  
Lights or flashes green if the VX-2000SF's CPU fails for any reason.
- 5. Service switch [SERVICE]**  
Used only for service maintenance.  
Do not touch this switch during normal system operations.
- 6. Initial setting indicator**  
Continuously lights green during the initial setting of the VX-200SZ.  
For the VX-200SZ initial setting instructions, refer to [p. 10-10](#).
- 7. Initial setting switch [INITIAL]**  
Performs the initial setting of the VX-200SZ Impedance Detection module.
- 8. Reset key [RESET]**  
Restores the unit to the same condition as results when the VX-2000's power is turned OFF and ON again.
- 9. Setting DIP switch [SETTINGS]**  
Sets the Unit ID No. and terminator ON/OFF.  
Refer to [p. 8-24](#) for the switch settings.
- 10. Firmware update PC card slot [ATA FLASH CARD]**  
The PC memory card used to update the VX-2000SF's firmware is inserted into this slot.
- 11. PC card indicator [ACCESS]**  
Lights green while reading data after the PC card is accessed.
- 12. Audio signal bus input connector [AUDIO LINK IN]**  
This RJ45 connector connects to the VX-2000 System Manager's AUDIO LINK OUT connector.
- 13. Audio signal bus output connector [AUDIO LINK OUT]**  
This RJ45 connector connects to the AUDIO LINK IN connector of an additional VX-2000SF Surveillance Frame. It can be insulated by installing an insulating transformer in the unit.  
For the installation instructions, refer to [p. 8-27](#).
- 14. Standby amplifier link connector [STANDBY PA LINK]**  
This RJ45 connector connects to the standby amplifier input.
- 15. DS-SF link connector [DS-SF LINK 1, 2]**  
This RJ45 connector connects to the VX-2000DS' DS-SF Link connector or VX-3000DS' DS Link IN connector. Data such as battery charging status, AC/DC power status, and failures of the charging circuit or battery can be retrieved from the VX-2000DS or VX-3000DS through this connector.
- 16. Data link connector [DATA LINK]**  
This RJ45 connector connects to the Data Link connector of the VX-2000 or additional VX-2000SF Surveillance Frame.
- 17. Ground terminal**
- 18. DC power input [DC POWER IN]**  
Connects to the DC POWER OUT terminal of the VX-2000DS or VX-3000DS unit.
- 19. Module slots (1 – 10)**  
A total of 10 units of VX-200SP Pilot Tone Detection module, VX-200SZ Impedance Detection module, VX-200SI Control Input module, and VX-200SO Control Output module can be installed.

## 2.9. Pilot Tone Detection Module VX-200SP

Install this module in the VX-2000SF Surveillance Frame to detect speaker line short circuits, open circuits by monitoring for the presence of a pilot signal, and ground fault.

[Front]

[Side]

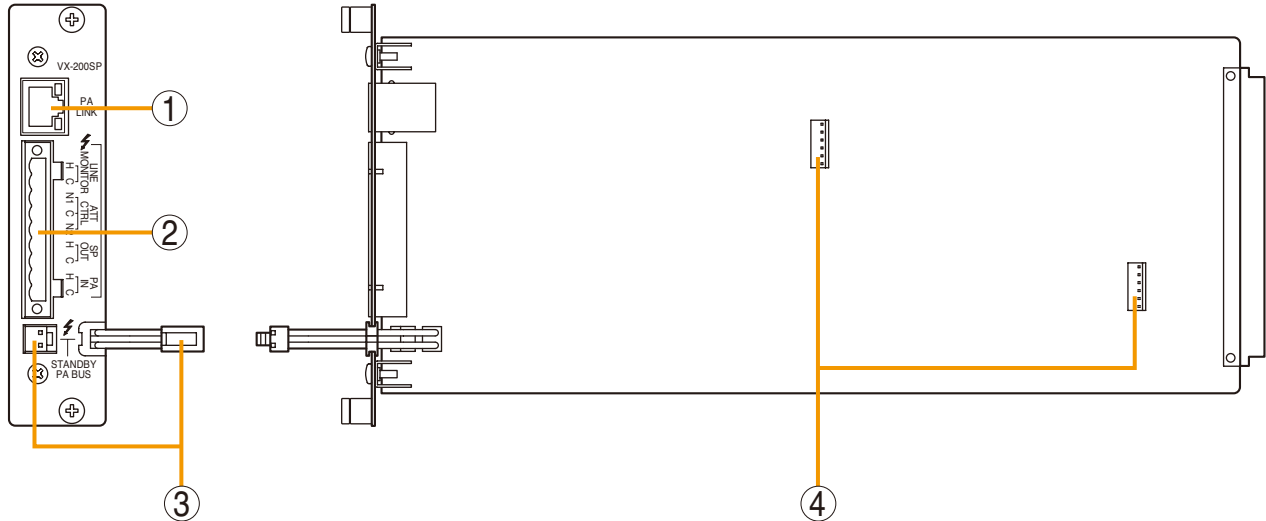

### 1. Power amplifier link connector [PA LINK]

This RJ45 connector connects to the PA LINK connector of the VP-200VX Power Amplifier Input module or the VP-3000 series Power Amplifier. Both LEDs on this connector are not used.

### 2. VX-200SP plug-in screw connector

Signal lines to be connected are shown below:

- **Line monitor input [LINE MONITOR]**  
Monitors connected speaker lines.  
Connect by wiring from the speaker line end.
- **External attenuator control [ATT CTRL]**  
Permits connection of a 3- or 4-wire system attenuator.  
For the attenuator connection, refer to [p. 9-7](#).
- **Speaker output [SP OUT]**  
Connects to the speaker.
- **Power amplifier input [PA IN]**  
Connects to the power amplifier's speaker output terminal.

### 3. Standby amplifier bus connector [STANDBY PA BUS]

Connects to all outputs of a single VX-2000SF unit to be switched over to the standby amplifier when the power amplifier fails. For details, refer to [p. 9-9, 9-10](#) for Standby Amplifier Connection.

### 4. VX-200SE mounting connector

Used to mount the VX-200SE Equaliser Card.



## 2.10. Impedance Detection Module VX-200SZ

Install this module in the VX-2000SF Surveillance Frame to detect speaker line short circuits, open circuits by comparing impedance readings, and ground fault.

### Important Note

When combining this module with the VP-200VX BGM Input Module, then the signal level applied to the VP-200VX's external input should be low, i.e. about 10 dB below the rated level. The level can also be reduced by the volume adjustment.

[Front]

[Side]

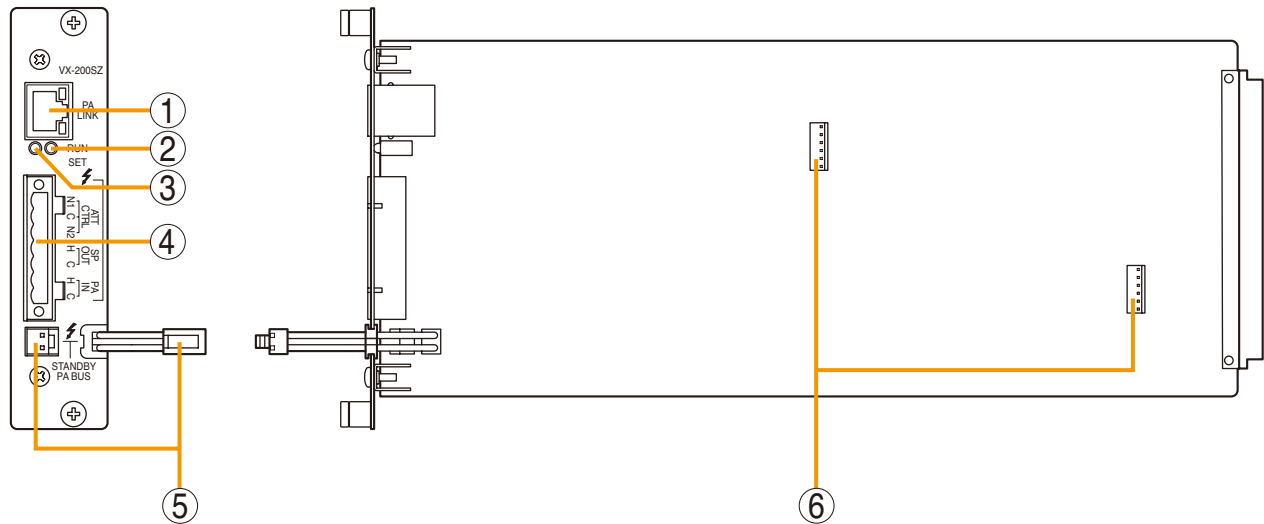

#### 1. Power amplifier link connector [PA LINK]

This RJ45 connector connects to the PA LINK connector of the VP-200VX Power Amplifier Input module or the VP-3000 series Power Amplifier. Both LEDs on this connector are not used.

#### 2. Run indicator [RUN]

Flashes green when system equipment is operating correctly.

#### 3. Set indicator [SET]

Indicates system initialisation setting status.

- Off: Initialisation undone (factory-set)
- Flashes green: Initialisation in progress
- Lights green: Initialisation completed

#### 4. VX-200SZ plug-in screw connector

Signal lines to be connected are shown below:

- **External attenuator control [ATT CTRL]**  
Permits connection of 4-wire system attenuators. For the connection instructions, refer to [p. 9-7](#). The attenuator bypass method can be changed from relay to photocoupler type. For the modification instructions, refer to [p. 8-29](#).

#### • Speaker output [SP OUT]

Connects to the speaker.

#### • Power amplifier input [PA IN]

Connects to the power amplifier's speaker output.

#### 5. Standby amplifier bus connector [STANDBY PA BUS]

Connects to all outputs of a single VX-2000SF unit to be switched over to the standby amplifier when the power amplifier fails.

For details, refer to [p. 9-9](#), [9-10](#) for Standby Amplifier Connection.

#### 6. VX-200SE mounting connector

Used to mount the VX-200SE Equaliser card.

## 2.11. Equaliser Card VX-200SE

The VX-200SE Equaliser is a 9-band, 1-channel equaliser to be mounted on the circuit board of the VX-200SP Pilot Tone Detection module or VX-200SZ Impedance Detection module.

Equaliser settings are performed using the PC system software. For the setting instructions, refer to [p. 7-37](#) "8.3. Equaliser Setting" (PC software offline settings).

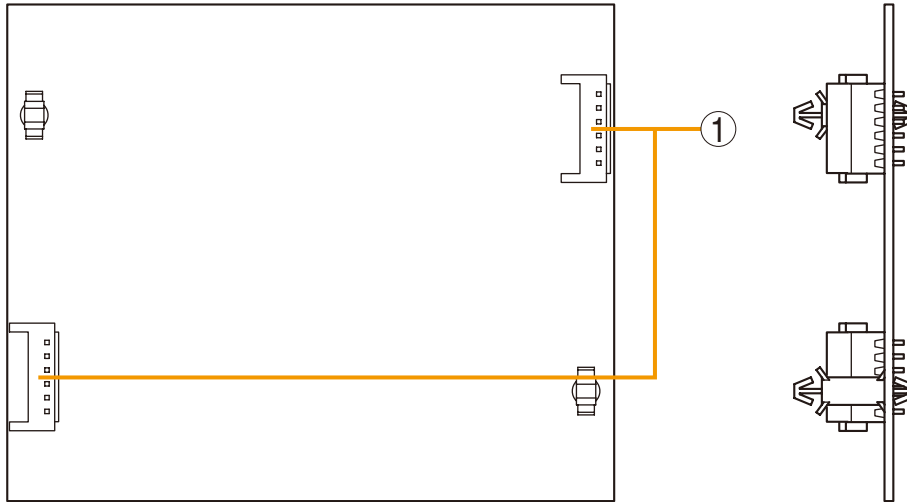

### 1. Mounting connector

Fit this connector into the VX-200SE mounting connector on the circuit board of the VX-200SP or VX-200SZ.

## 2.12. Control Input Module VX-200SI

Install this module in the VX-2000SF Surveillance Frame when in use.

The VX-200SI receives a contact signal from connected external equipment and controls the system.

By increasing the number of Control input modules, the system can have up to 128 control inputs, including the System Manager's 16 control inputs.

[Front]

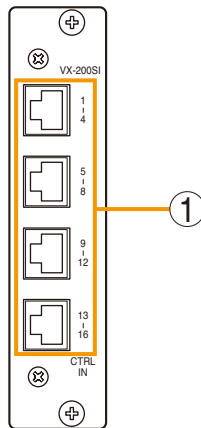

### 1. Control input connector [CTRL IN 1 – 4, 5 – 8, 9 – 12, 13 – 16]

This RJ45 connector connects to equipment components that output control signals.

The CTRL 1 – 4 input can be insulated by internal modification.

For the modification instructions, refer to [p. 8-32](#).

Logic (make or break) for the CTRL 1 – 16 input can also be switched by changing the position of the internal switch. For the switch position selection, refer to [p. 8-31](#).

## 2.13. Control Output Module VX-200SO

Install this module in the VX-2000SF Surveillance Frame when in use.

No-voltage 'make' contacts can be output to external equipment depending on the internal event.

By increasing the number of Control output modules, the system can have up to 128 control outputs, including the System Manager's 16 control outputs.

[Front]

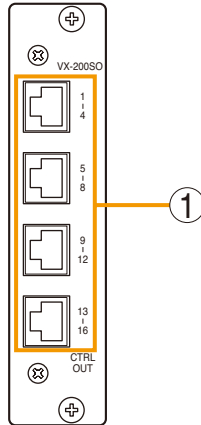

### 1. Control output connector [CTRL OUT 1 – 4, 5 – 8, 9 – 12, 13 – 16]

This RJ45 connector connects to equipment components that are activated by make contact signals.

## 2.14. Power Amplifiers VP-2064, VP-2122, VP-2241, and VP-2421

Four different configurations of power amplifiers can be used in the VX-2000 system: 60 W x 4 channels, 120 W x 2 channels, 240 W x 1 channel, and 420 W x 1 channel versions. Mount a VP-200VX Power Amplifier Input module for each channel used.

### [Front]



This figure shows VP-2064.

### [Rear]

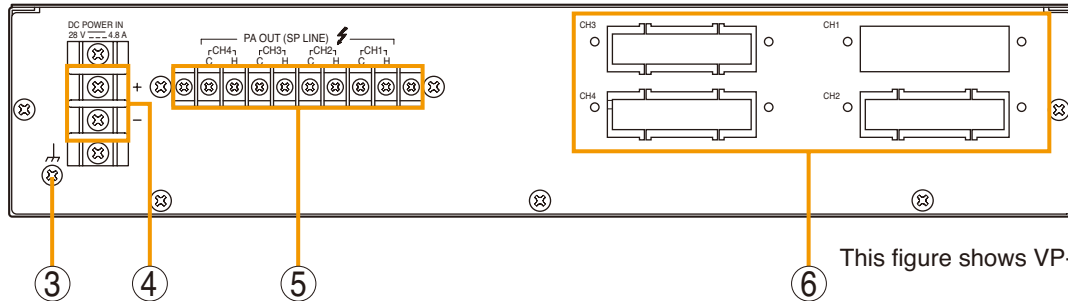

This figure shows VP-2064.

#### 1. Channel power indicator [POWER]

Only the lamp for the input module-mounted channel lights green when the power is supplied.

- Off: VP-200VX not installed
- Lights green: In-use status
- Lights red: Standby status or DC fuse blowout

#### 2. Overheat indicator [OVERHEAT]

If the internals of the power amplifier overheat, this indicator lights yellow and the power amplifier's operation is stopped.

#### 3. Ground terminal

#### 4. DC power input [DC POWER IN]

Connects to the VX-2000DS/3000DS unit's DC POWER OUT terminal.

#### 5. Output terminal [PA OUT (SP LINE)]

Connects to the power amplifier input terminal of the VX-200SP or VX-200SZ module mounted in the VX-2000SF Surveillance Frame.

The speaker line output voltage can be changed with an internal modification.

For the modification procedure, refer to [p. 8-34](#).

#### 6. Module slot

Insert the VP-200VX Power Amplifier Input module into this slot.

## 2.15. Power Amplifiers VP-3154, VP-3304, and VP-3504

Three different configurations can be used in the VX-2000 system: 150 W x 4 channels, 300 W x 4 channels, and 500 W x 4 channels.

### Note

The VP-3000 series amplifiers can be used in conjunction with the VX-3000DS only, but not with the VX-2000DS.

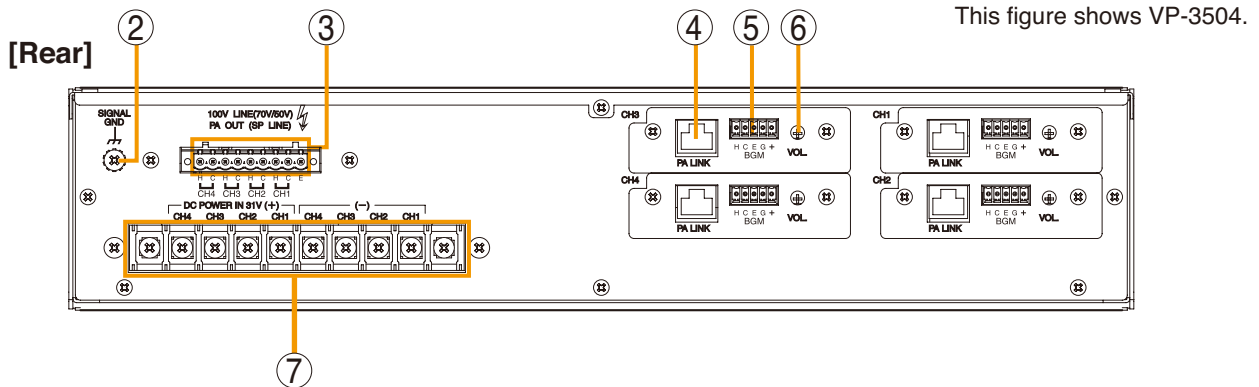

This figure shows VP-3504.

### 1. Channel Status Indicators [SIGNAL, PEAK, OPERATE, POWER]

- OPERATE and POWER indicators

**OPERATE:** Indicates whether power amplifier is normally operating (lit green) or not (unlit).

**POWER:** Indicates whether power is supplied to the amplifier (lit green) or not (unlit).

Operating Status	OPERATE	POWER
In-use	● Lit	● Lit
Standby	○ Unlit	● Lit
DC fuse blowout	○ Unlit	○ Unlit
Protection*1 activated	○ Unlit	● Lit

\*1 The built-in protection circuit operates if some irregularities occur inside the amplifier such as abnormal temperature rise or fan failure.

- SIGNAL and PEAK indicators  
SIGNAL indicators light green and PEAK indicators light red when input signals applied to the PA LINK connector (4) or the BGM input terminal (5) exceed the following levels.

[Input signal levels to light indicators]

Input terminal	SIGNAL indicators	PEAK indicators
PA LINK connector's audio input	-20 dB*2	-2.5 dB*2
BGM input (-10 dB*2*3)	-30 dB*2	-12.5 dB*2
BGM input (0 dB*2*4)	-20 dB*2	-2.5 dB*2

\*2 0 dB = 1 V

\*3 Factory-preset sensitivity

\*4 Sensitivity after modification (see p. 8-42.)

### 2. Functional Earth Terminal [SIGNAL GND]

Hum noise may be generated when external equipment is connected to the unit. Connecting this terminal to the functional earth terminal of the external equipment may reduce the hum noise.

**Note:** This terminal is not for protective earth.

### 3. Output Terminals [PA OUT (SP LINE)]

Connect to the power amplifier input terminal of the VX-200SP or VX-200SZ module mounted in the VX-2000SF Surveillance Frame.

The speaker line output voltage can be changed by internal modification.

For the modification procedure, see p. 8-40.

**4. PA Link Connector [PA LINK]**

This RJ45 connector connects to the power amplifier output of the VX-200SP or VX-200SZ module.

When this unit is used as the standby amplifier, connect to the VX-2000SF's standby PA LINK connector.

Output audio signals are transmitted to the power amplifier, and the power amplifier's audio monitor signals are returned to this PA link connector.

It is also possible to retrieve data regarding power amplifier overheating status and blown DC fuses.

Hum noise may be generated by a ground loop of the PA link's audio input accidentally created in the system. To cut off the ground loop, make the ground lift setting referring to the procedure on p. 8-41.

**5. BGM Input Terminal [BGM]**

Removable terminal block (5P), BGM signal input:  $-10\text{ dB}^{*1*2}/600\ \Omega$  balanced, Mute input: no-voltage make contact.

Receives BGM signals and BGM mute control signal (make contact).

When the Mute input terminals are closed, BGM signals are muted.

[Pin function]

H	C	E	G	+
BGM signal input			Mute input	
Hot	Cold	Earth	Ground	Control input

\*1 0 dB = 1 V

\*2 Can be changed to "0 dB\*1." (see p. 8-42.)

**6. BGM Volume Control [VOL.]**

Adjusts the BGM input level.

If the PEAK indicator lights red, reduce the BGM output level at the BGM source equipment or BGM input level with this volume control.

**7. DC Power Input Terminal [DC POWER IN]**

Connects to the VX-3000DS Emergency Power Supply's DC power output terminal.

## 2.16. Power Amplifier Input Module VP-200VX

Insert this module into the Power Amplifier's Input module slot when in use.

### [Front]

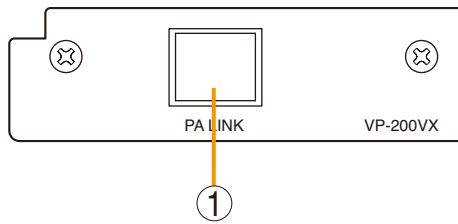

#### 1. Input connector [PA LINK]

This RJ45 connector connects to the power amplifier output of the VX-200SP or VX-200SZ module.

When this module is mounted on the standby amplifier, connect to the VX-2000SF's standby PA LINK connector. Output audio signals are transmitted to the power amplifier, and the power amplifier's audio monitor signals are returned to the module.

It is also possible to retrieve data regarding power amplifier overheating status and blown DC fuses.



# ***Chapter 3***

---

## ***SYSTEM OPERATION OUTLINE***

## 1. OPERATION MODES

### 1.1. Drive Mode

The system can be set to operate in either "Normal" or "Economy" mode when the power is switched on. Use the PC software to set the drive mode.

- **Normal Mode**

The normal drive mode in which all amplifiers except standby amplifiers are in active status. System failures are automatically monitored once every within 100 seconds.

- **Economy Mode**

Unused amplifiers are placed in standby mode, and are switched to active status only when they are used for broadcast.

System failures are automatically monitored once every 24 hours.

#### [About amplifier status and indication]

Active Status: Normal state of operation. The Channel LED lights green.

Standby Status: All amplifier control sections are operative, however, to reduce power consumption, no power is supplied to the sections that actually amplify the output signals. Channels in standby mode are indicated by corresponding red Channel LEDs.

### 1.2. System Operation Mode

The system's operation mode changes when there is a power failure or the emergency mode is activated, thereby changing the status of the unused amplifiers and monitoring intervals.

System Operation Mode	Power Supply Status	Unused Amplifier	Monitoring Interval	General Broadcast
Normal	AC	Active status	Within 100 seconds	Enabled
Economy	AC	Standby status	Within 24 hours	Enabled
AC failure	Battery	Standby status	Interval set by PC software	Disabled
Emergency	AC or battery	Active status	Within 100 seconds	Disabled

#### Notes

- The system automatically reverts to its most recent operation mode after the emergency mode is reset.
- General broadcast stops automatically when the system enters the mode in which general broadcast is disabled.

#### [System Operation Mode]

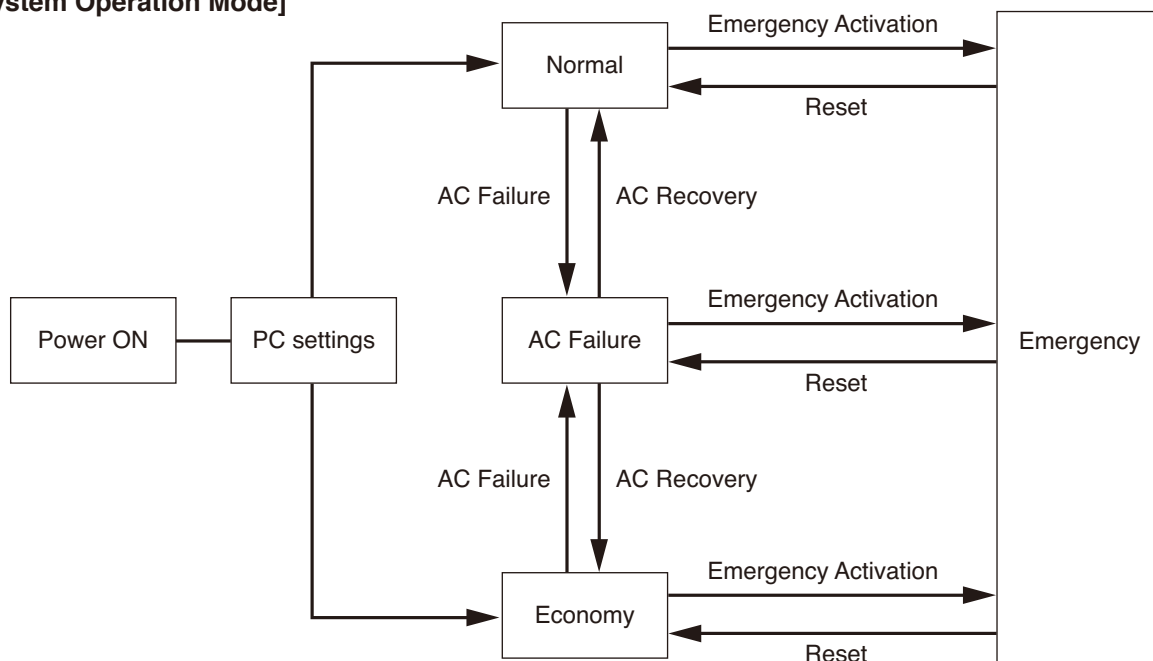

## 2. MONITOR FUNCTION

In the VX-2000 system, the entire system is monitored during operation.

- Should any failure be detected, it is indicated by lighting the Failure LEDs of all connected RM-200X, RM-200XF, VX-2000 and VX-2000SF units.

### Note

When an RM-200X Remote Microphone set for General type fails, this is recorded in the operation log. However, the Failure LEDs of the RM-200X, RM-200XF, VX-2000 and VX-2000SF do not light.

- More precise failure locations can be indicated by preparing failure output patterns that contain PC-designated failure sources, and assigning such patterns to the Remote Microphone function keys. In this case, a failure of the RM-200X set for General type can also be indicated. A single control output can be interlocked with the failure output pattern.

Refer to p. 4-5 for details regarding failure output patterns, to p. 5-34 for Remote Microphone operations when failures are detected, and to p. 7-51 for PC software settings.

### 2.1. Continuous Monitoring

Monitoring intervals differ depending on operation mode. The entire system is monitored once every within 100 seconds in Normal and Emergency Modes, while one monitoring is carried out every 24 hours in Economy mode. Monitoring intervals in AC failure mode need to be set using a PC.

#### [Items to be monitored]

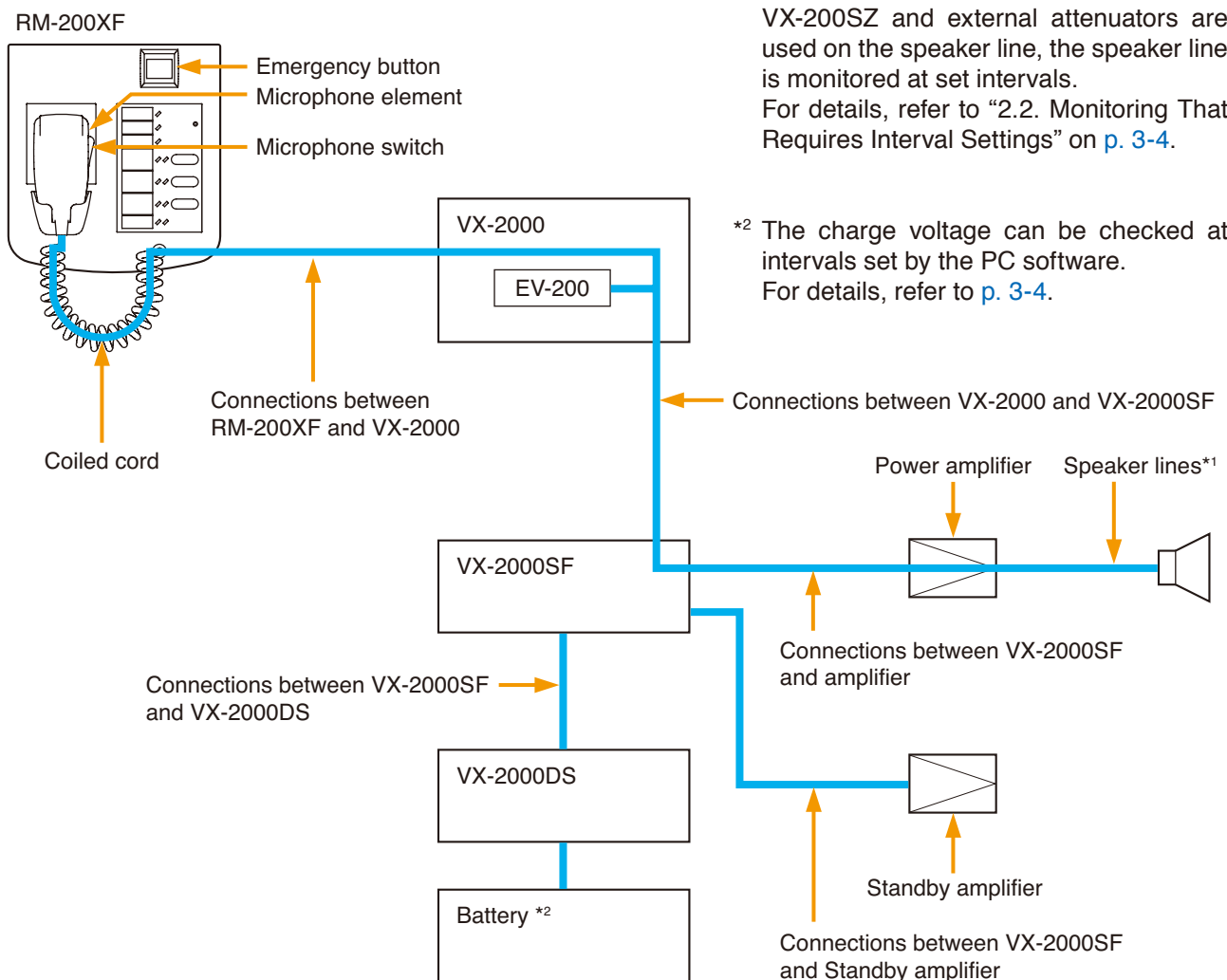

## 2.2. Monitoring That Requires Interval Settings

### • Battery Monitoring

Set the time interval for checking the backup batteries for correct voltage. Monitoring can be set for Daily (time), Weekly (day and time) or Monthly (date and time) intervals. Use the PC software to perform these settings. Refer to [p. 7-29](#) for the setting procedure.

### • Monitoring in AC Failure Mode

In AC failure mode, the system is powered by the battery. To minimize battery power consumption in this case, all amplifiers not used for broadcast are placed in standby mode regardless of the drive mode setting, causing their channel power LEDs to light red.

Each amplifier is switched to active mode only while being monitored (its channel power LED lights green). Because the system monitoring consumes battery power, the monitoring interval in AC failure mode needs to be set not for the "Within 100 seconds" as normal monitoring mode but for either "Every 1 – 24 hours, 1-hour units" or "Every 1 – 60 minutes, 1-minute units" using the PC software. For setting the monitoring interval, refer to [p. 7-29](#).

#### **Note**

In AC failure mode, general broadcast cannot be performed.

### • Impedance Monitoring

The VX-200SZ Impedance Detection module is designed to detect speaker line failures by comparing their impedance. When external attenuators are used through speaker lines, they must be bypassed for correct monitoring or correct failure detection.

Because sound volume will suddenly increase if an attenuator should be bypassed during broadcast, set the monitoring interval not for the "Within 100 seconds" as normal monitoring mode but for either "Every 1 – 24 hours, 1-hour units" or "Every 1 – 60 minutes, 1-minute units" using the PC software. For setting the monitoring interval, refer to [p. 7-14](#).

For the operation details about external attenuator control terminals, refer to [p. 3-7](#).

#### **Notes**

- All VX-200SZ units using external attenuators in the system are monitored at the same timer intervals.
- Time intervals set above are rendered invalid in AC failure mode, and monitoring is carried out at the time intervals set above in the "Monitoring in AC Failure Mode" explanation.
- It is highly recommended that monitoring be performed in idle periods of time because sound volume will suddenly increase if attenuators are bypassed during broadcast.

### 3. AMPLIFIER STANDBY FUNCTIONS

A single standby amplifier can be provided per VX-2000SF. When a system amplifier failure is detected, that amplifier is automatically switched over to the standby amplifier.

- Because the standby amplifier is in standby mode when not in use, the CH LED lights red. When in use, the CH LED lights green.
- Standby amplifiers are also monitored for failures, as with other equipment, depending on the operation mode. The CH LED lights green during monitoring.

#### Notes

- The system continues to display the failure indication until the amplifier that failed is restored to normal condition. For the reset procedures, refer to [p. 5-36](#) of this manual.
- Only a single standby amplifier can be connected per VX-2000SF. If one amplifier fails, it is switched over to the standby amplifier. Should other amplifier failures be detected, broadcasts cannot be made to their corresponding zones.
- When all-zone broadcasts are made by turning off the RM-200XF's CPU switch (refer to [p. 3-9](#)), standby amplifier broadcasting is disabled. Therefore, broadcasts cannot be made to any zone currently switched over to the standby amplifier owing to amplifier failure.

#### Example

When a failure of Amp 2 is detected, the amplifier is automatically switched over to the standby amplifier. In this event, the standby amplifier's CH LED changes from steady red to steady green conditions.

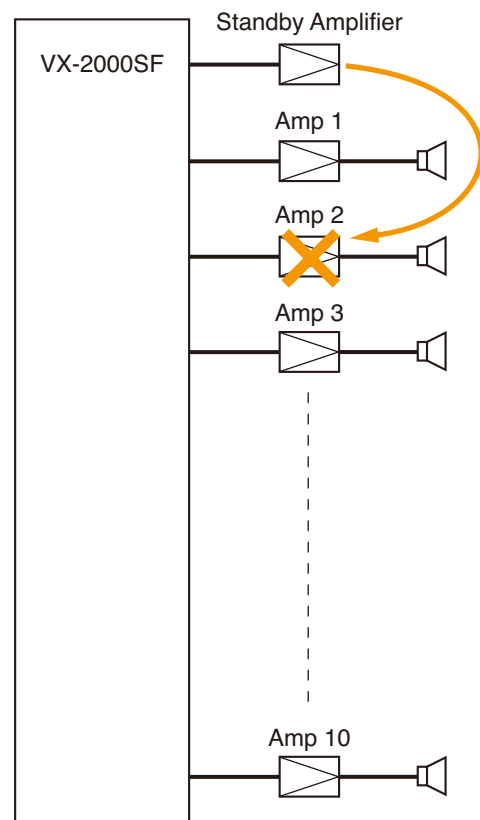

## 4. SPEAKER LINE FAILURE DETECTION METHODS

### Note

The failure detection functions described here are designed to perform on a 100-volt line of speaker. For the methods using a 70- or 50-volt line, please consult your TOA dealer.

### 4.1. Impedance Detection Method

The VX-200SZ Impedance Detection module compares impedances to detect speaker line failures. A 40Hz pilot signal for impedance detection is superimposed on the signal line. The VX-200SZ checks the impedance before the [SP OUT] terminal, and compares it with the initially set impedance to detect speaker line failures. The VX-200SZ module's initial impedance value must be set at the time of installation or during periodic service maintenance.

Refer to p. 10-10 for the initialisation method.

#### [VX-200SZ Failure detection]

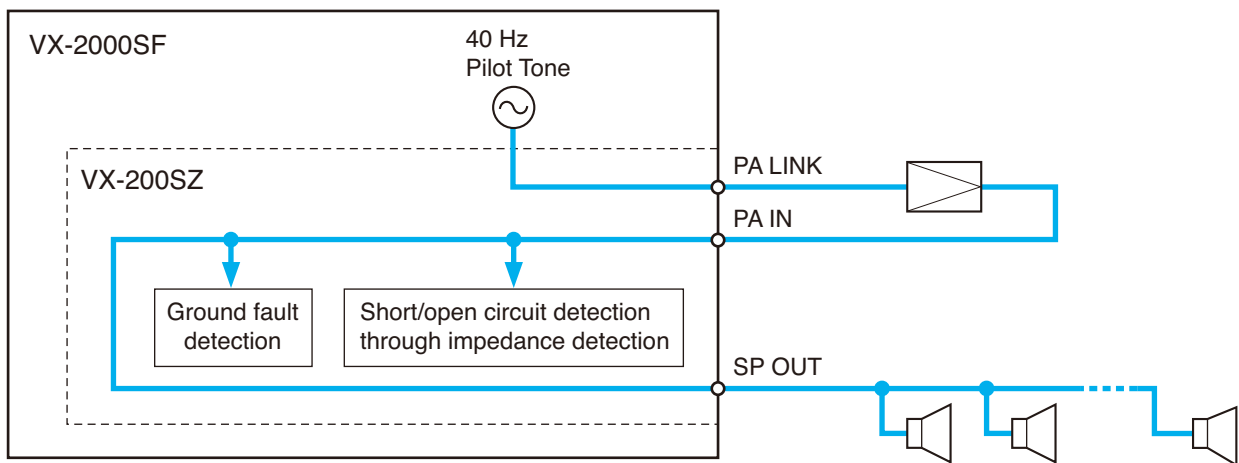

### 4.2. Pilot Tone Detection Method

The VX-200SP Pilot Tone Detection module detects speaker line failures by using a pilot tone. A 20kHz failure detection pilot signal is superimposed on the signal line. To detect speaker line failures, the VX-200SP checks the signal return from the speaker line end to the LINE MONITOR terminal.

#### [VX-200SP Failure detection]

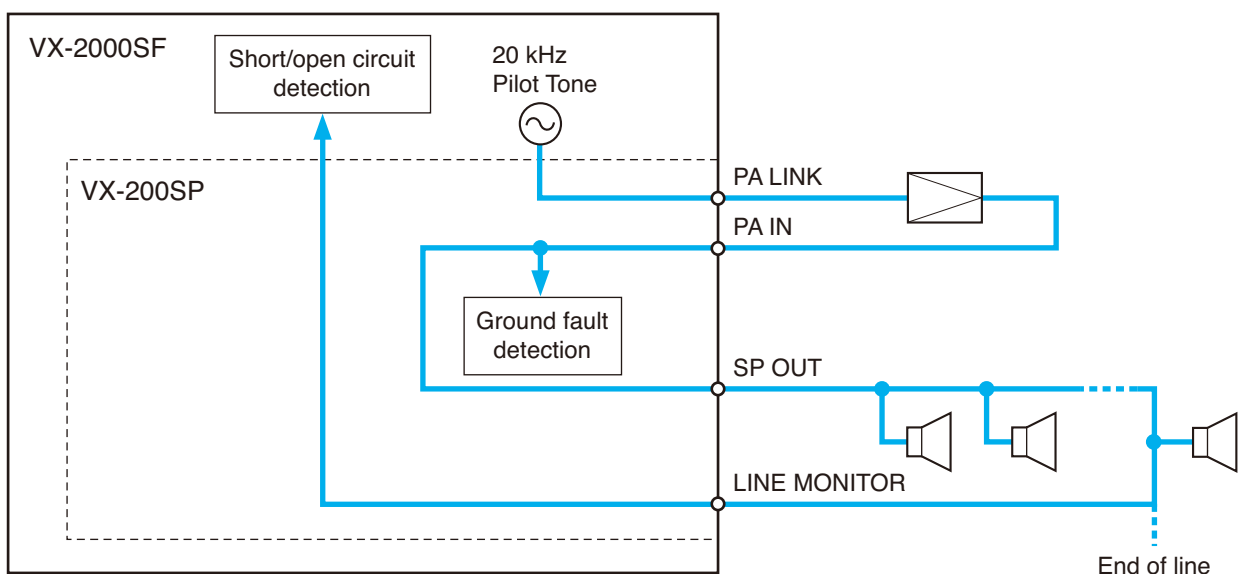

## 5. EXTERNAL ATTENUATOR CONTROL TERMINAL OPERATION

Both the VX-200SZ and VX-200SP are equipped with control terminals that enable them to bypass external attenuators. Depending on the system operation status, the External Attenuator Control terminals work in either the "Valid" (N2 - C terminals closed) or "Bypassed" (N1 - C terminals closed) mode.

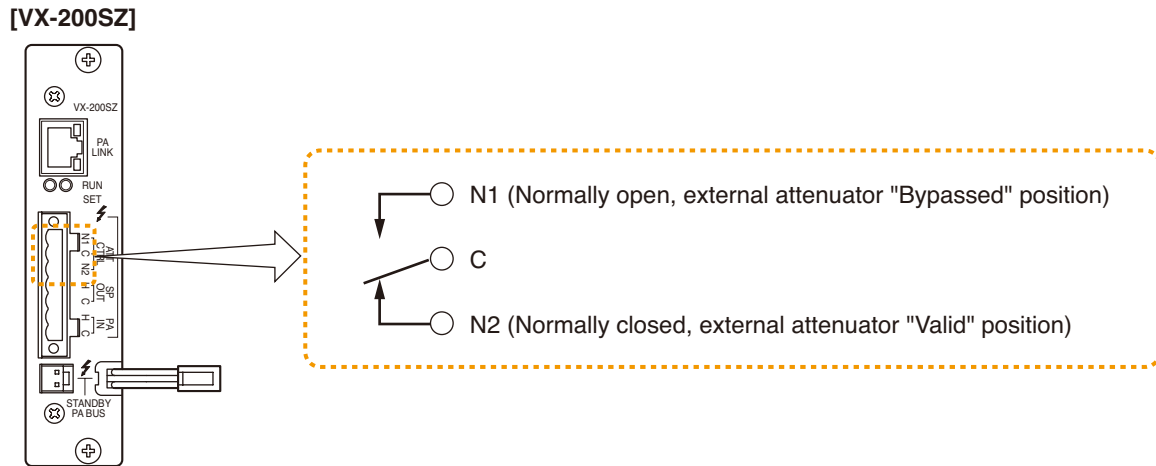

### 5.1. Operation

The External Attenuator Control terminals are switched to either the "Valid" position or "Bypassed" position depending on whether broadcasting is being made or broadcast modes.

When paging from a Remote Microphone or EV message broadcast is made, the attenuator control terminals are switched to the "Valid" position, permitting the broadcast to go through at full (attenuator-bypassed) volume.

Broadcast	Broadcast Mode	External Attenuator Control Terminals
ON	BGM broadcast	Valid (N2 - C terminals closed)
	Paging broadcast	Bypassed (N1 - C terminals closed)
	EV broadcast Emergency broadcast	
OFF		Bypassed (N1 - C terminals closed)

#### Notes

- BGM refers to input sources designated by the PC software as "Used as BGM."
- The attenuator control terminals are set for the "Bypass" position (N1 - C terminals closed) while the CPU is off.
- For connections to external attenuators, refer to [p. 9-7](#).

## 5.2. Operation During Monitoring

### [VX-200SZ]

Because the VX-200SZ monitors speaker lines by comparing their impedance, when external attenuators are used, they are bypassed to monitor the system. When connecting an external attenuator to the VX-200SZ, set as "Use external attenuator" in the PC software, then set the monitoring time interval.

Monitoring time intervals and External Attenuator Control terminal operations differ depending on the operation mode and whether or not external attenuators are used.

Operation Mode	External Attenuator	Monitoring Intervals	Control Terminal Operation during Monitoring
Normal or Emergency	Unused	Within 100 seconds	Not work
	Used	Set by the PC setting*1	Bypasses external attenuators.
Economy	Unused	24 hours	Not work
	Used	Set by the PC setting*1	Bypasses external attenuators.
AC Failure	Unused	Set by the PC setting*2	Not work
	Used	Set by the PC setting*2	Bypasses external attenuators.

\*1 PC Setting : Impedance Monitoring Interval Setting

\*2 PC Setting : Monitor Interval in AC Failure Mode

### Note

When external attenuators are used, they are bypassed at set monitoring time intervals, even during BGM broadcasts.

### [VX-200SP]

Because the VX-200SP monitors speaker lines by checking with a pilot tone, external attenuators need not be bypassed during monitoring. In this case, the Attenuator Control terminals do not operate during monitoring.

The VX-200SP carries out monitoring at intervals that correspond to the operation mode. For details, refer to the table below.

Operation Mode	Monitoring Intervals	Control Terminal Operation during Monitoring
Normal or Emergency	Within 100 seconds	Not work
Economy	24 hours	
AC Failure	Set by the PC setting*3	

\*3 PC Setting : Monitor Interval in AC Failure Mode



## 6. CPU SWITCH

The VX-2000 system features a fail safe-function which enables all-zone broadcasts even if the system's CPU fails. If the CPU cannot correctly control system performance due to its failure, all-zone announcements can be made from the RM-200XF Remote Microphone by setting the RM-200XF's CPU switch to the OFF position.

Setting the RM-200XF's CPU switch to the OFF position causes the CPU indicator to light red. No control is performed by the VX-2000 System Manager's CPU as long as the CPU switch is in the OFF position. (This is possible only when the VX-2000's CPU is operating.)

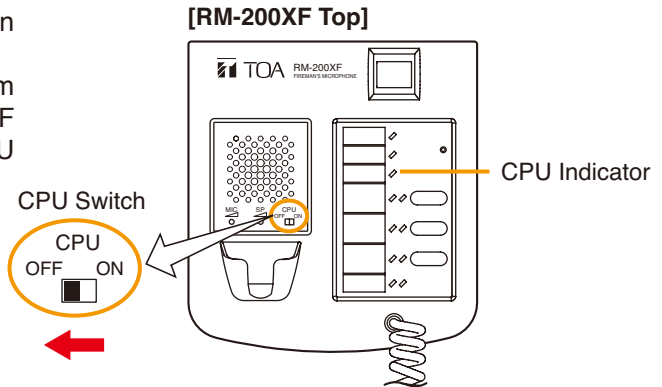

### Operation of each system component when the CPU switch is set to OFF

#### [RM-200XF]

- The CPU indicators on all RM-200XF Remote Microphones within the system light red, and all other indicators-excluding the power indicator-extinguish. In this event, indicators on additional RM-210 Extension units installed in the system also extinguish.
- As long as at least one CPU switch is turned OFF, announcements can be made to all zones from all RM-200XF units in the system regardless of other's CPU switch setting. If simultaneous broadcasts are made from 2 or more RM-200XF units, they are mixed together. With the CPU switch set to OFF, the RM-200XF's talk key performs PTT (press-to-talk) operation regardless of the PC software setting.

#### [RM-200X]

The failure indicator lights red, and all other indicators-including the power indicator-extinguish. Indicators on all added RM-210 Extension units also extinguish.

#### [VX-2000]

The CPU OFF terminals on the rear panel are closed.

#### Note

The VX-2000's CPU OFF terminals are not only closed when the RM-200XF's CPU switch is set to OFF, but also when no control is performed by the VX-2000 System Manager's CPU.

#### [VX-200SZ and VX-200SP]

The external attenuator control terminals N1 and C are shorted.

When external attenuators are connected to these terminals, they are bypassed.

#### [VX-200SO]

All control output terminals are opened.

### CPU OFF function and module slots

The CPU off function is available only at the module slots 2, 4, 6 and 8. So use these slots for the input modules connected to fireman microphones RM-200XF that shall provide the CPU off function.

The CPU off function is not available only at the module slots 1, 3, 5 and 7.

Other remote microphones can be connected to input modules in any slot.

#### Notes

- When making all-zone broadcasts by turning off the RM-200XF's CPU switch, standby amplifier broadcasting is disabled. This means that broadcasts cannot be made to any zone currently switched over to the standby amplifier owing to amplifier failure.
- CPU switch ON/OFF data are recorded in the system operation log. (This is possible only when the VX-2000's CPU is operating.)

## 7. SWITCHING OFF SYSTEM POWER

In the system example below, the VX-2000DS is used for backup power supply. For the system employing the VX-3000DS unit instead of the VX-2000DS, refer to the instruction manual attached to the VX-3000DS.

When it is necessary to open the equipment's case for modification or change of setting, the system's power needs to be switched off.

If the DC power supply from the VX-200PS to the VX-2000DS stops, the VX-2000DS automatically switches the system's power supply over to the battery. The system power can be switched off without switching over to the battery by using the VX-2000DS' Setting switch that enables the VX-2000DS to operate in conjunction with other systems than VX-2000 system.

Refer to the Instruction Manual attached to the VX-2000DS for the method to use the VX-2000DS with other systems and switch off the system power (DC).

### Note

Stopping the AC power supply to the VX-2000DS automatically switches the power supply over to the battery. Take care not to stop the AC power supply to the VX-2000DS.

### [Whole power supply system]

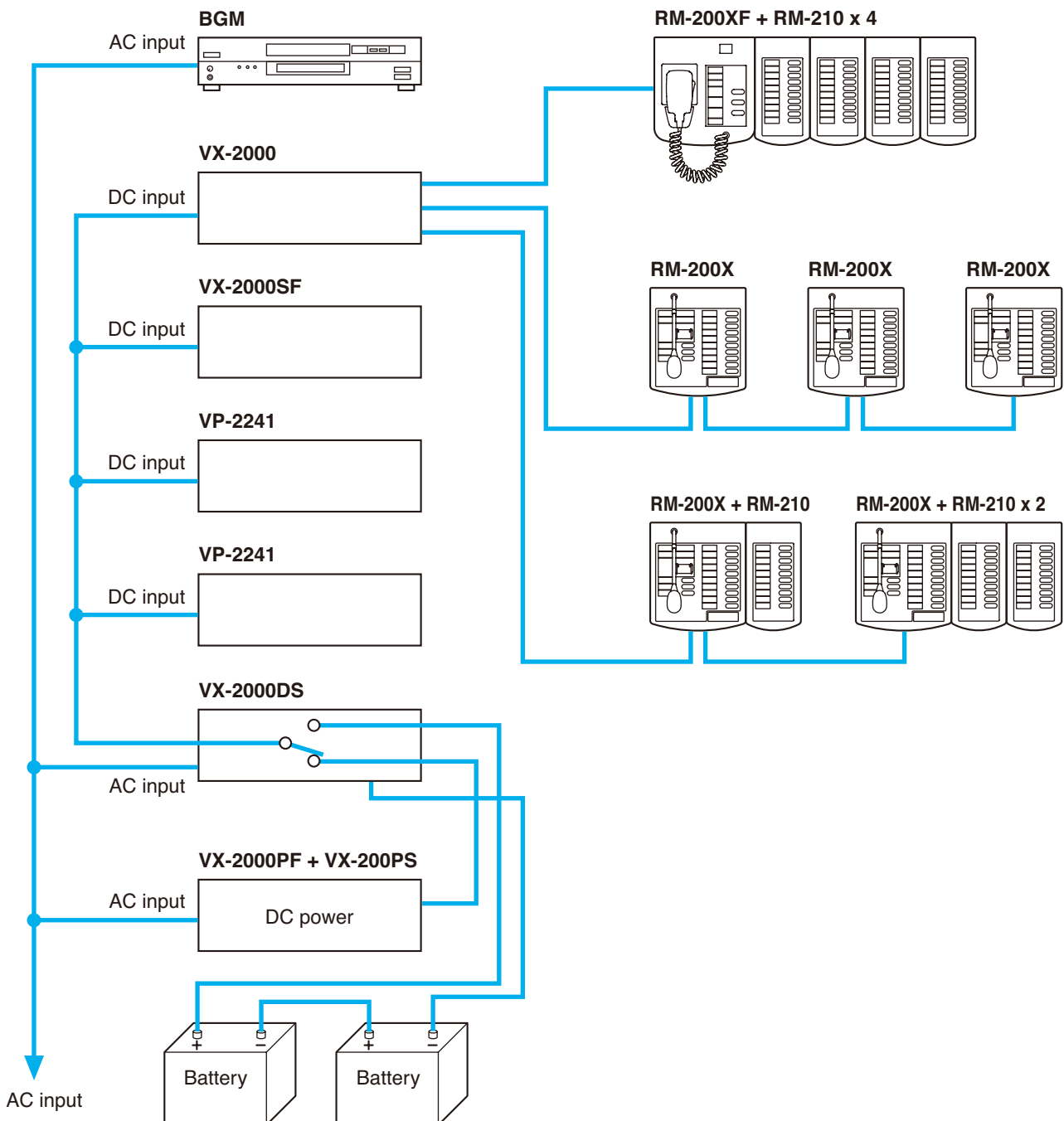







## 8. BROADCAST PRIORITIES

Broadcast priorities are broadly divided into 4 categories, which are classified in the following priority order:

1. **Emergency RM:** Broadcasts from the Remote Microphone designated as Emergency type.
2. **Emergency EV:** EV messages (Reset, Evacuation and Alert messages) set as Emergency in EV Message Type.
3. **General:** Broadcasts from the Remote Microphone designated as General type, broadcasts of general-purpose EV messages, and broadcasts from sound sources not set as BGM.
4. **BGM:** Broadcasts from sound sources set as BGM.

Use the PC software to set priorities. Refer to [p. 7-30](#) for the setting procedure.

### [Setting Example]

Priority	Priority order classified by category	Setting within the category	Priorities within the same category	FIFO/LIFO* when same priority level
High   Low	Emergency RM	<div style="display: flex; justify-content: space-between;"> <div style="border: 1px solid black; padding: 2px;">RM-1 (Emergency)</div> <div style="border: 1px solid black; padding: 2px;">RM-2 (Emergency)</div> </div>	Priority high   Priority low	<ul style="list-style-type: none"> <li>• Broadcasts shown side-by-side are of the same priority level.</li> <li>• Either FIFO or LIFO can be set if same priority level.</li> </ul>
	Emergency EV	<div style="display: flex; justify-content: space-between;"> <div style="border: 1px solid black; padding: 2px;">Reset 1</div> <div style="border: 1px solid black; padding: 2px;">Reset 2</div> </div> <div style="display: flex; justify-content: space-between; margin-top: 5px;"> <div style="border: 1px solid black; padding: 2px;">Evacuation 1</div> <div style="border: 1px solid black; padding: 2px;">Evacuation 2</div> </div> <div style="display: flex; justify-content: space-between; margin-top: 5px;"> <div style="border: 1px solid black; padding: 2px;">Alert 1</div> <div style="border: 1px solid black; padding: 2px;">Alert 2</div> </div>	Determined according to Message Type. "Reset" "Evacuation" "Alert" in order of high to low.	<ul style="list-style-type: none"> <li>• Same priority level if same Message Type.</li> <li>• Always LIFO for the same level.</li> </ul>
	General	<div style="display: flex; justify-content: space-between;"> <div style="border: 1px solid black; padding: 2px;">RM 3 (General)</div> <div style="border: 1px solid black; padding: 2px;">General EV1</div> </div> <div style="display: flex; justify-content: space-between; margin-top: 5px;"> <div style="border: 1px solid black; padding: 2px;">RM 4 (General)</div> <div style="border: 1px solid black; padding: 2px;">General EV2</div> </div> <div style="border: 1px solid black; padding: 2px; margin-top: 5px; width: 100%;">PM-660U</div>	Priority high   Priority low	<ul style="list-style-type: none"> <li>• Broadcasts shown side-by-side are of the same priority level.</li> <li>• Either FIFO or LIFO can be set if same priority level.</li> </ul>
	BGM	<div style="display: flex; justify-content: space-between;"> <div style="border: 1px solid black; padding: 2px;">BGM 1</div> <div style="border: 1px solid black; padding: 2px;">BGM 2</div> </div>	No priority order within category. All same priority level.	<ul style="list-style-type: none"> <li>• Always LIFO.</li> </ul>

\* FIFO: First-in-first-out priority

\* LIFO: Last-in-first-out priority

### 8.1. Duplicate Broadcasts from both Higher and Lower Priority Equipment

While BGM is being broadcast to Zones 1, 2, and 3, if RM-1 makes broadcasts to Zone 3, BGM output in Zone 3 is interrupted, allowing RM-1 to go through because RM-1 is given priority over BGM.

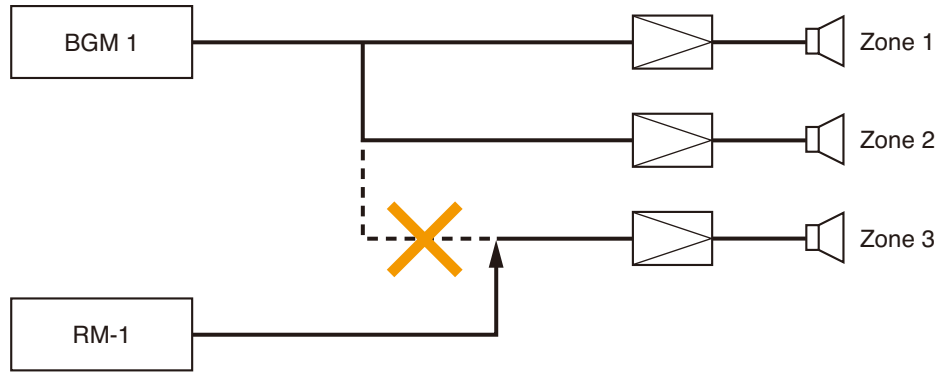

## 8.2. FIFO/LIFO Priorities

Set FIFO (first-in-first-out) or LIFO (last-in-first-out) priority when 2 or more sources are identical in priority level. This setting is possible for both Emergency RM and General categories.

**FIFO:** Priority is given to the first-enabled source. Other sources of the same priority level must wait until the first-enabled source finishes its broadcast.

**LIFO:** Priority is given to the source last enabled. While one source is broadcasting, if another equipment source makes a broadcast, the current broadcast is interrupted, allowing the broadcast of the latter source to go through.

### [FIFO broadcasts to the same zone]

While RM-3 is making broadcasts to Zones 1 and 2, if General EV1 of the same priority level makes broadcasts to Zones 2 and 3, General EV1 is allowed to go through to Zone 3 but cannot broadcast to Zone 2 until RM-3 is finished.

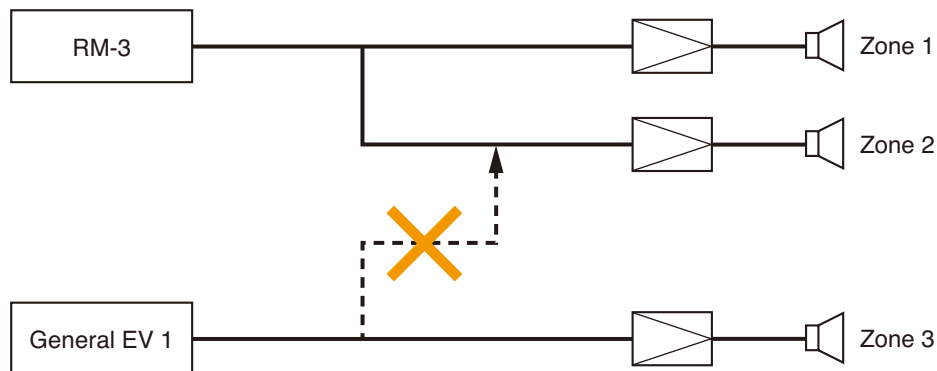

### [LIFO broadcasts to the same zone]

While RM-3 is making broadcasts to Zones 1 and 2, if General EV1 of the same priority level makes broadcasts to Zones 2 and 3, RM-3's broadcast to Zone 2 is interrupted, and General EV1 can make broadcasts to both Zones 2 and 3.

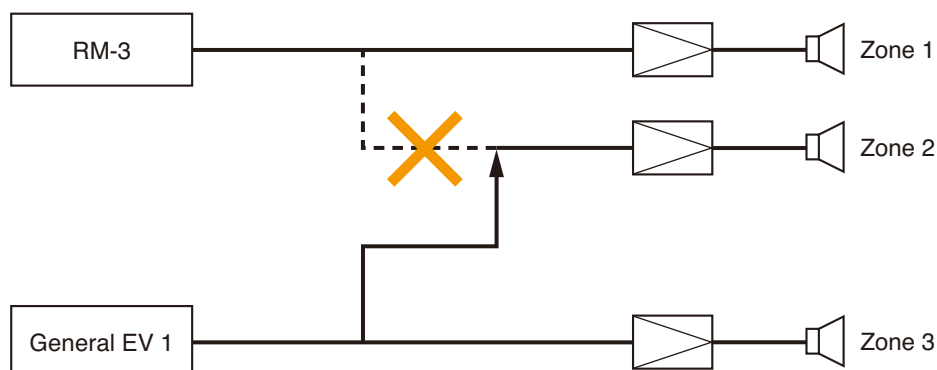

### 8.3. Broadcasts from the Daisy-Chain Connected Remote Microphones

When Remote Microphones are connected in a daisy-chain fashion to a single VX-200XR, only 1 Remote Microphone among those can make broadcasts. The broadcast-enabled Remote Microphone is determined on a priority basis such as highest, FIFO, or LIFO priority of which settings are applicable among daisy-chained Remote Microphones.

**[Broadcasts from RM-3 given higher priority than RM-4, or FIFO Broadcasts from both Remote Microphones of the same priority level]**

While RM-3 is broadcasting to Zones 1 and 2, if RM-4 attempts to broadcast to Zones 2 and 3, it cannot broadcast to any zone. RM-4 must wait until RM-3 finishes its broadcast.

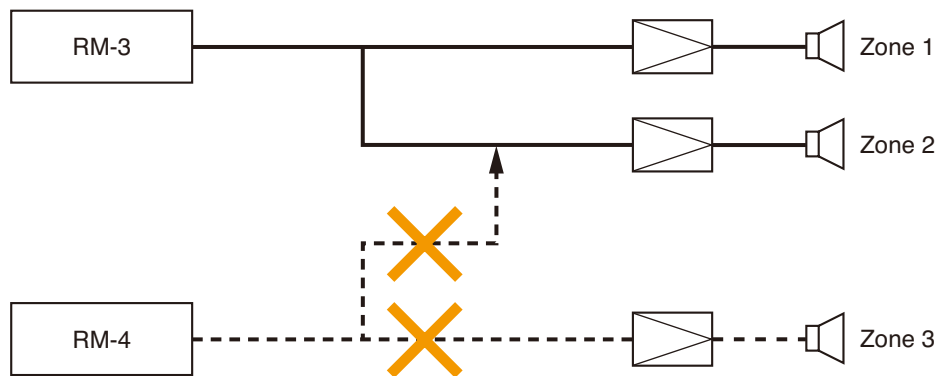

#### Tip

Up to 4 Remote Microphones of Emergency type can be daisy-chain connected to a single VX-200XR.

In this connection system, however, when the Remote Microphone with highest priority makes broadcast, others with lower priority are disabled for broadcast.

It is recommended that every Emergency type unit be made one-to-one connection to the VX-200XR if individual units are intended to make broadcasts to different zones in Emergency mode.

As for the RM-200X unit designated as General type, it may be connected in a daisy chain to the Emergency type unit because the RM-200X will not operate in Emergency mode.

- During broadcast from the Remote Microphone with highest priority, other Remote Microphones are disabled for broadcast.

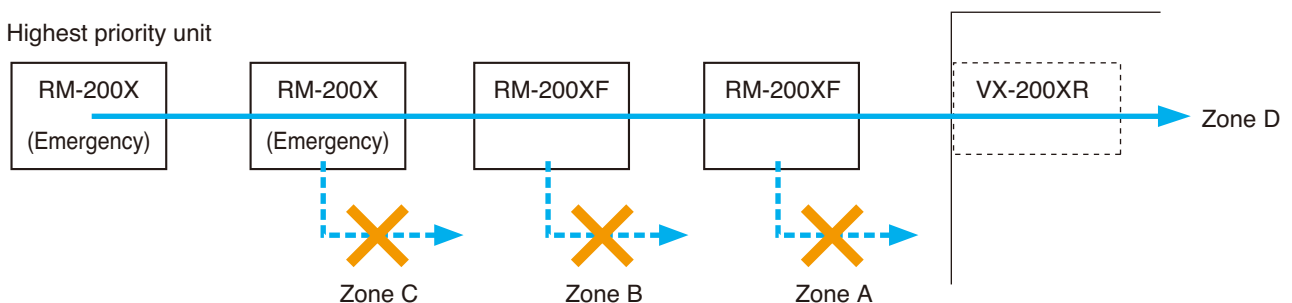

- When all Emergency type Remote Microphones are one-to-one connected to each VX-200XR, they can independently make broadcasts to their corresponding zones.

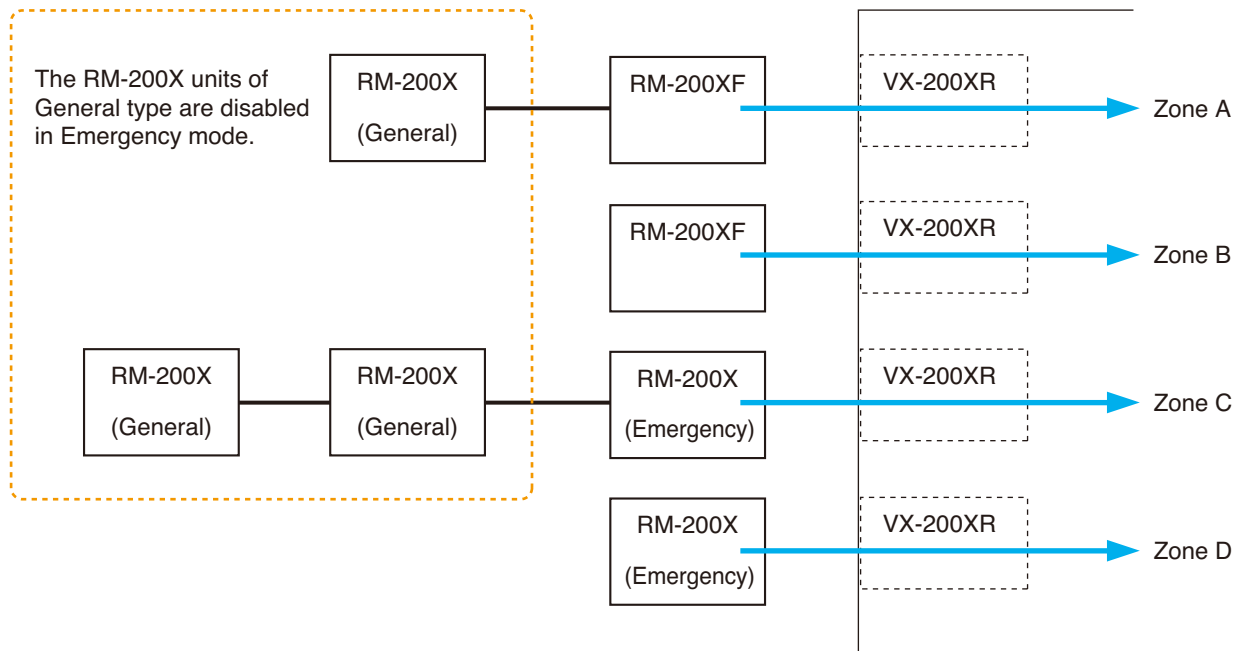

**[Broadcasts from RM-4 given higher priority than RM-3, or LIFO Broadcasts from both RM-3 and RM-4 of the same priority level]**

RM-4 can broadcast to Zones 2 and 3 while RM-3 is broadcasting to Zones 1 and 2. The current broadcast is terminated in Zone 1, and broadcasts from RM-4 are made in Zone 2 instead of RM-3 broadcasts.

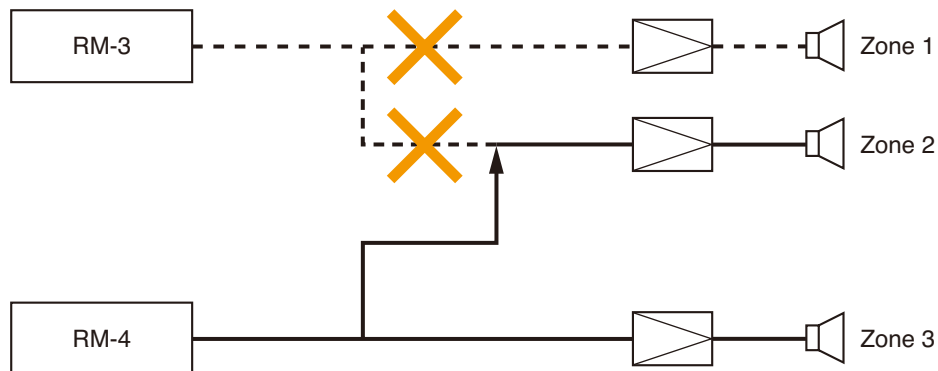

# ***Chapter 4***

---

## ***FUNCTIONS***



## 1. OPERATION OUTLINE

The VX-2000 system features 3 types of Activation Items: Remote Microphone function keys, control input terminals, and internal timer.

The VX-2000 system makes broadcasts or performs operations by assigning various functions to these 3 types of Activation Items. Patterns, in which broadcast inputs and outputs and signal routings are preprogrammed, can be created and assigned to the Activation Items.

Other functions can also be set in addition to patterns. All settings are performed by way of the system's dedicated PC software, and the system can be operated by downloading the prepared setting data to the VX-2000.

### [VX-2000 System Activation Items]

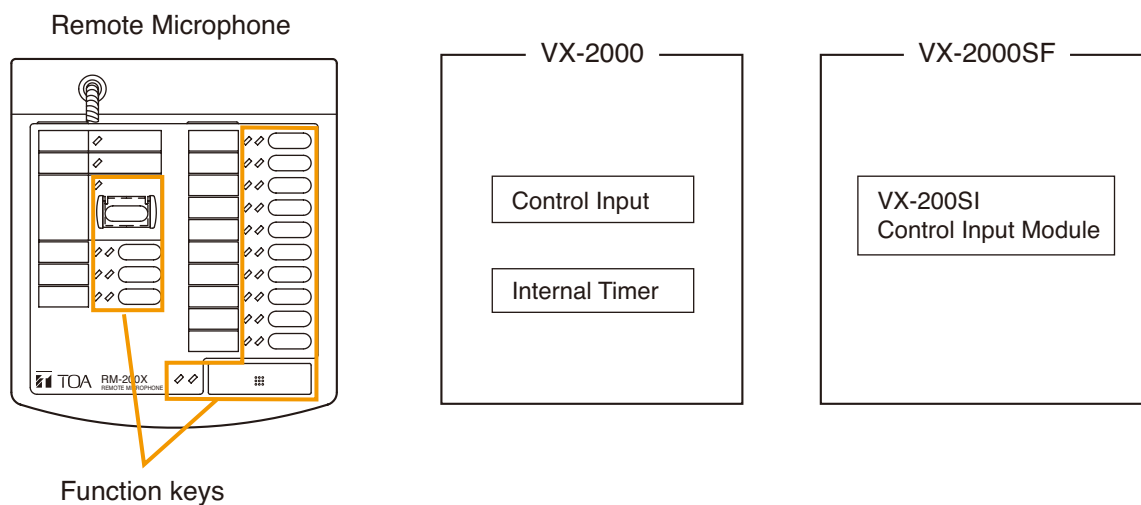

- **Remote Microphone Function Keys**

Besides broadcast and control pattern recall, such functions as Audio Monitor, broadcast zone selection, and microphone announcement can be assigned to these keys. Assignment of the system failure indication function makes it possible to indicate detected failures by way of the Remote Microphone buzzer and function key LED indicator.

- **Control Input (VX-2000 or VX-200SI)**

In addition to broadcast and control pattern recall, monitor zone selection can be assigned to this input. It is also possible to assign such functions as the lighting of RM, VX, and SF failure LEDs when failure data is received from an external source, or correction of internal timer settings.

- **Internal Timer**

Broadcast and control patterns can be recalled at preset times.

Refer to [p. 4-3](#), "Preparing Patterns," for details regarding broadcast and control patterns, and to [p. 4-6](#), "Activation Items," for details regarding Activation Items.

## 2. PATTERNS

In the VX-2000 system, patterns of broadcast settings and operation controls are created using its dedicated PC software, and are assigned to Activation Items (such as the Remote Microphone function keys, control input, and internal timer). Broadcasts can be made and control functions performed by recalling assigned patterns using the Remote Microphone function keys or control input operation, or activation by way of the internal timer. Use the PC software to create and assign patterns to the Activation Items.

### 2.1. Emergency Broadcast Patterns

The emergency broadcast patterns include emergency EV messages and their corresponding broadcast zones. Use the PC software to create the emergency broadcast patterns. For details, refer to [p. 7-39](#).

Pattern Type	Feature
Dual-origin EV message broadcast (Two EV-200 units used.)	<ul style="list-style-type: none"> <li>• Two different emergency EV messages can be broadcast to individual zones using 2 EV-200 units.</li> <li>• Up to 50 Alert EV message patterns and up to 50 Evacuation EV message patterns can be set.</li> <li>• One or more control outputs activated in synchronisation with the patterns can be set.</li> </ul>
Single-origin EV message broadcast	<ul style="list-style-type: none"> <li>• Emergency EV messages and their corresponding broadcast zones can be changed by switching the pattern from Phase-1 to Phase 2 at preset time intervals.</li> <li>• Up to 50 patterns can be set.</li> <li>• One or more control outputs activated in synchronisation with the patterns can be set.</li> </ul>
No EV unit installed.	<ul style="list-style-type: none"> <li>• Emergency broadcast patterns cannot be created.</li> <li>• One or more control outputs activated in synchronisation with emergency activation can be set.</li> </ul>

#### Note

When 2 or more patterns are simultaneously recalled, the system operates as follows:

#### [Dual-origin EV Broadcasts]

- If the assigned EV messages are the same, the message is broadcast to all zones set in each of the simultaneously recalled patterns.
- If the assigned EV messages are different, but the recalled pattern output zones are duplicated, the message assigned the highest priority is broadcast to all duplicated zones.  
Example: Pattern A includes an Evacuation message (highest priority) output to zones 1 – 5. Pattern B includes an Alert message output to zones 3 – 7. When both patterns are simultaneously recalled, Pattern A is broadcast to zones 1 – 5, while Pattern B can only be broadcast to zones 6 and 7.

#### [Single-origin EV Broadcasts]

Broadcasts are made to every zone set in each of the simultaneously recalled zones.

## 2.2. Control/General-Purpose Broadcast Patterns

Use the PC software to create the desired patterns. For details, refer to [p. 7-45](#).

Pattern Type	Feature
Control output pattern	<ul style="list-style-type: none"> <li>• Allows to output control signals to external equipment. The control output is shorted by activation from a remote microphone or a control input. It can also remain shorted for a period of time set by the internal timer.</li> <li>• One or more control outputs are set.</li> <li>• Up to 50 patterns can be created.</li> </ul>
Interrupt broadcast pattern	<ul style="list-style-type: none"> <li>• Allows the broadcast higher than BGM in priority. Interrupt broadcast can be made by activation from a control input. It can also be made continue for a period of time set by the internal timer.</li> <li>• Input sound sources including BGM sources, and their corresponding output zones are set.</li> <li>• Up to 50 patterns can be created.</li> <li>• One or more control outputs activated in synchronisation with the pattern can be set.</li> </ul>
EV broadcast pattern	<ul style="list-style-type: none"> <li>• Allows broadcasts of EV messages from the EV-200 mounted in the VX-2000. EV messages are recalled and broadcast by activation from a control input. They can also be broadcast at a set time determined by the internal timer.</li> <li>• Includes general-purpose EV messages and their corresponding output zones.</li> <li>• Up to 20 patterns can be created.</li> <li>• One or more control outputs activated in synchronisation with the pattern can be set. The control output is shorted during the duration of the EV message broadcast.</li> </ul>
Base pattern	<ul style="list-style-type: none"> <li>• Allows BGM broadcast. BGM broadcast can be made by remote microphone operation or a control input operation. It can also be made at a set time determined by the internal timer.</li> <li>• Includes BGM sources and corresponding output zones.</li> <li>• Up to 20 patterns* can be created.</li> <li>• One or more control outputs activated in synchronisation with the pattern can be set.</li> </ul>
Volume pattern	<ul style="list-style-type: none"> <li>• Allows to control an input sensitivity or output zone volume. The volume can be controlled by activation from a remote microphone or a control input. It can also remain changed for a period of time set by the internal timer.</li> <li>• Input: This pattern includes individual input sources excluding Remote Microphones.</li> <li>• Output: In this pattern, one or more output zones are set.</li> <li>• A total of up to 156 patterns can be created for both the input and output.</li> </ul>

### Notes

Interrupt and EV broadcast patterns can be simultaneously recalled. When simultaneously recalled, the system operates as follows:

[Interrupt Broadcast]

- If the assigned input sources are the same, broadcasts are made to every output zone set in all recalled patterns.
- If the assigned input sources are different, but the recalled pattern output zones are duplicated, the input source assigned the highest priority is broadcast to all duplicated zones, while other recalled sources are broadcast to the corresponding output zones that are not among the duplicated zones.

\* Available when the VX-2000 Setting Software Version 3.0 or later is installed.

**[EV Broadcast]**

- If the assigned EV messages are the same, the message is broadcast to every zone set in all recalled patterns.
- If the assigned EV messages are different, but the recalled pattern output zones are duplicated, the EV message assigned the highest priority is broadcast to all duplicated zones, while other recalled messages are broadcast to the corresponding output zones that are not among the duplicated zones.

**2.3. Failure Output Patterns**

Failure output patterns are used to indicate the locations of failures when detected. Up to 315 patterns can be created for equipment, amplifier, speaker and power supply systems, and several failure sources can be set per pattern.

**[Failure source table]**

Equipment	Power Amplifier	Speaker	Power Supply	CIN Fault* <sup>2</sup>
<ul style="list-style-type: none"> <li>• Remote Microphone</li> <li>• EV-200</li> <li>• VX-2000</li> <li>• VX-2000SF</li> <li>• External Fault CIN*<sup>1</sup></li> </ul>	<ul style="list-style-type: none"> <li>• Power amplifier</li> <li>• Standby power amplifier</li> </ul>	<ul style="list-style-type: none"> <li>Speaker line</li> <li>• Open circuit</li> <li>• Short circuit</li> <li>• Ground fault</li> </ul>	<ul style="list-style-type: none"> <li>• VX-2000DS</li> <li>• VX-3000DS</li> </ul>	<ul style="list-style-type: none"> <li>• VX-200SI</li> </ul>

**[Method to indicate a failure]**

Assigning the Failure Output Pattern to the Remote Microphone's function key causes the Failure LED to light and the built-in buzzer to sound when a failure included in the pattern occurs.

One control output can be set in the Failure Output Pattern and is turned ON when a failure included in the pattern occurs. Using this control output permits visual indication such as lamp to light for an external failure indication.

Use the PC software to create failure output patterns. For details, refer to [p. 7-51](#).

For details on operations and indications when failures are detected, refer to [p. 5-34](#).

\*<sup>1</sup> Available when the VX-2000 Setting Software Version 2.1 or later is installed.

\*<sup>2</sup> Available when the VX-2000 Setting Software Version 3.0 or later is installed.

### 3. ACTIVATION ITEMS

The VX-2000 has Activation Items, which are Remote Microphone (RM-200X and RM-200XF) function keys, control inputs, and internal timer.

The VX-2000 system can be operated by assigning broadcast and control patterns to the Activation Items. Functions other than pattern recall can also be set. Use the PC software to assign the desired functions.

For details, refer to [p. 7-52](#).

Patterns and functions that can be set for each Activation Item are explained here.

#### 3.1. Remote Microphone Function Keys

Items that can be assigned to the Remote Microphone function keys are shown below. LED indications change depending on the item.

[Table of items assignable to the Function Keys]

Item		Function	Left-Side LED Display contents	Right-Side LED display contents
Emergency	Emergency Activation	Activates Emergency mode. Broadcasts can also be made by recalling emergency broadcast patterns.	Emergency mode: Button or LED lights. General-purpose mode: Button or LED extinguished.	
	Emergency Alert EV*1	Recalls the Alert EV message.	EV can be used.	EV in use.
	Emergency Evacuation EV*1	Recalls the Evacuation EV message.	EV can be used.	EV in use.
	Emergency Reset*1	Restores the general-purpose broadcast mode. Broadcasts can also be made by assigning the Reset EV message.	Unused.	Unused.
	Silence*3	The EV message stops.	Silencing.	Unused.
Base Pattern Change		Recalls and broadcasts the base pattern.	Unused	Base pattern in use.
Base Pattern End		Stops BGM broadcasts.	Unused.	Base pattern not in use.
Control Output Interlock		Recalls the control output interlock pattern.	Unused.	In progress.
Audio Monitoring		Selects zones to monitor by way of the Remote Microphone monitor speaker.	Unused.	Monitoring in progress.
Volume UP Operation		Changes the assigned pattern volume level. Volume level increases by 3 dB each time the key is pressed.	Unused.	Volume increased.
Volume DOWN Operation		Changes the assigned pattern volume level. Volume level decreases by 3 dB each time the key is pressed.	Unused.	Volume decreased.
Failure Output Reception		The buzzer sounds when a failure of the assigned failure output pattern is detected. Pressing the key stops the buzzer and changes the failure detection indicator from flashing to steady-on status.	Failure detected.	Unused.
Failure Output Reset		Resets the failure detection indication.	Unused.	Unused.
Zone Selection		Pre-selects the zones.	Zone monitoring.	Pre-selection in progress.
All-Zone Selection		Pre-selects all zones.	Unused.	Pre-selection in progress.
Clear		Cancels zone pre-selections.	Unused.	Unused.
Talk		Enables microphone announcements.	Microphone ready for use.	Microphone in use.
General-Purpose EV Message		Recalls and broadcasts the general-purpose EV message.	EV ready for use.	EV in use.
Chime		Recalls and broadcasts the built-in chime.	Chime ready for use.	Chime in use.
Lamp Test*2		Executes the Lamp Test.	All indicators light in turn.	
Emergency Ack.*2		Stops the buzzer sound at the time of emergency broadcast.	Unused.	Unused.
Password Lock*2		Places the Remote Microphone in the status it cannot be operated without entering password.	Unused.	Flashing: Standby for password entry. Lit: Correct password entered.

\*1 Assigned to the RM-200X unit designated for "Emergency" use and the RM-200XF.

\*2 Available when the VX-2000 Setting Software Version 2.1 or later is installed.

\*3 Available when the VX-2000 Setting Software's Version 3.0 or later is installed.

### 3.1.1. Emergency

#### [Emergency activation]

- When using an emergency/general-purpose Remote Microphone  
When this microphone is used, the emergency mode is activated. If emergency patterns are assigned, the EV message set in the emergency broadcast pattern is broadcast to the pre-selected zones.
- When using a general-purpose Remote Microphone  
Emergency mode can only be activated.

[RM-200XF]

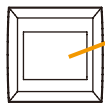

**Emergency Activation button**

- General-purpose mode: OFF
- Emergency mode: Lights red.

[RM-200X]

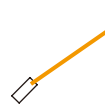

**Emergency LED**

- General-purpose mode: OFF
- Emergency mode: Lights red.

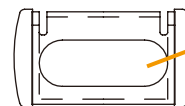

**Emergency Activation button**

#### [Emergency EV messages (Alert and Evacuation messages)]

The EV message is broadcast to the pre-selected zones.

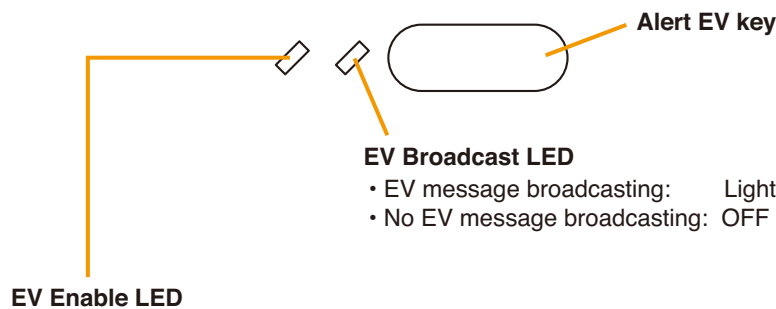

System Status		EV Enable LED	Broadcast Possible: ✓ Broadcast Impossible: ✗
Pre-selected zones not used by other equipment.		OFF	✓
Broadcasts made to pre-selected zones from other equipment.	Other equipment broadcast priority low.	Flashes green.	✓
	Other equipment broadcast priority high.	All zones	Flashes orange. ✗
Part of zones		Flashes green.	✓ (Broadcasts can be made to the remaining zones.)
Message in the same EV being currently broadcast	Broadcasting message priority high.	Flashes orange.	✗
	Broadcasting message priority low.	Flashes green.	✓

#### [Emergency Reset]

General-purpose broadcast mode is restored. If the Reset EV message has been assigned, the message is broadcast to the pre-selected zones.

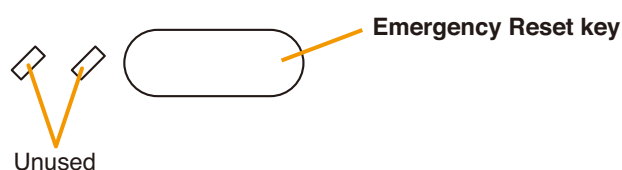

### 3.1.2. Base pattern change

The base pattern assigned to the key is recalled for broadcast.

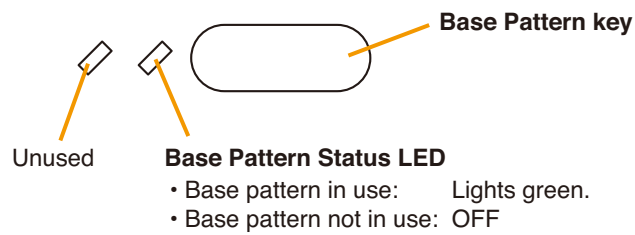

### 3.1.3. Base pattern end

BGM broadcasts stop.

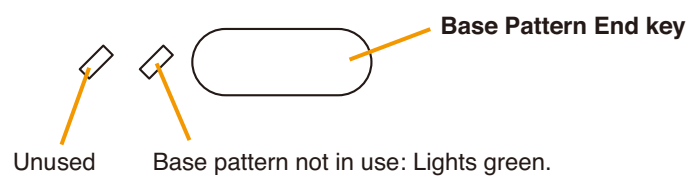

### 3.1.4. Control output interlock

The assigned control pattern is recalled and the control output terminal is closed while the key is pressed.

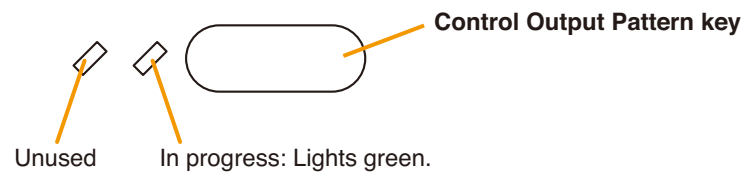

### 3.1.5. Audio monitoring

Individual zones can be set for monitoring. Pressing the key permits the current broadcast in the set zone to be monitored by way of the Remote Microphone monitor speaker for 10 seconds.

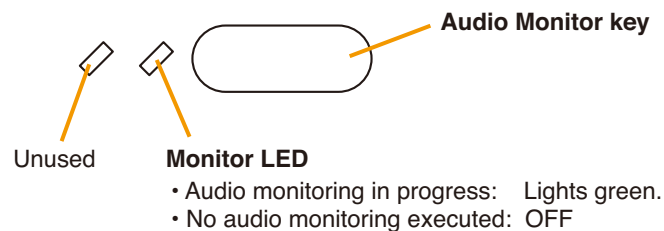

### 3.1.6. Volume UP operation

Raises the volume level set in Pattern Settings. The volume increases by 3 dB each time the key is pressed.

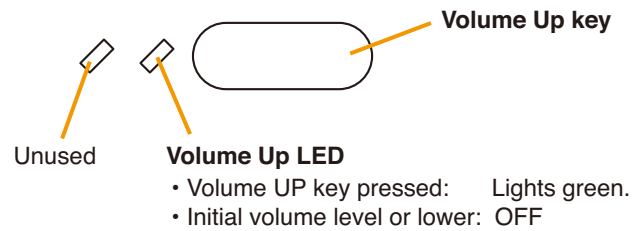

### 3.1.7. Volume DOWN operation

Lowers the volume level set in Pattern Settings. The volume decreases by 3 dB each time the key is pressed.

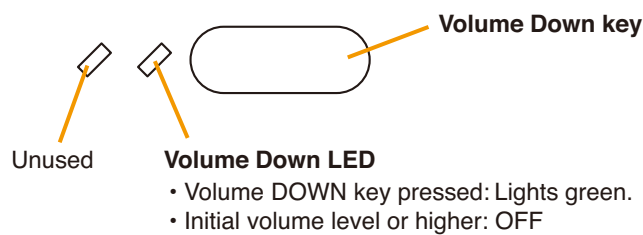

### 3.1.8. Failure output reception

When a failure corresponding to the pattern made in Surveillance Factors occurs, the failure indicator flashes accompanied by the buzzer. Pressing the key after checking to confirm a failure stops the buzzer and changes the failure indicator from flashing to continuously lit status.

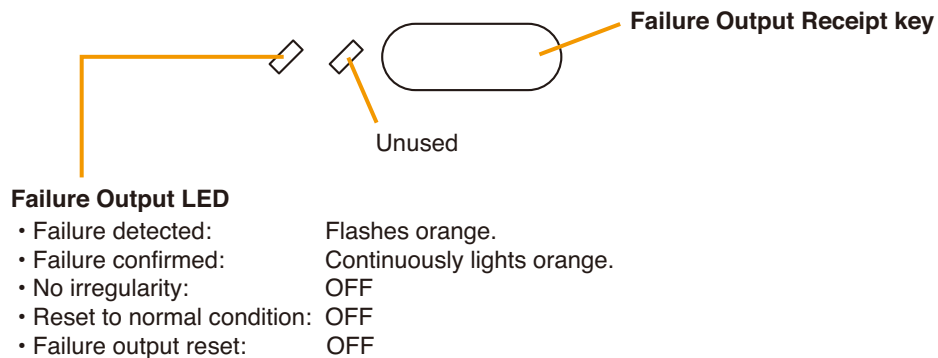

### 3.1.9. Failure output reset

Permits the failure status to be cleared and reset to exit the failure indication mode. (The failure indication is turned off, and the buzzer stops.)

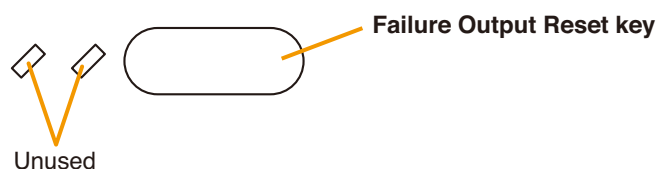



### 3.1.10. Zone selection

Pre-selects individual broadcast zones.

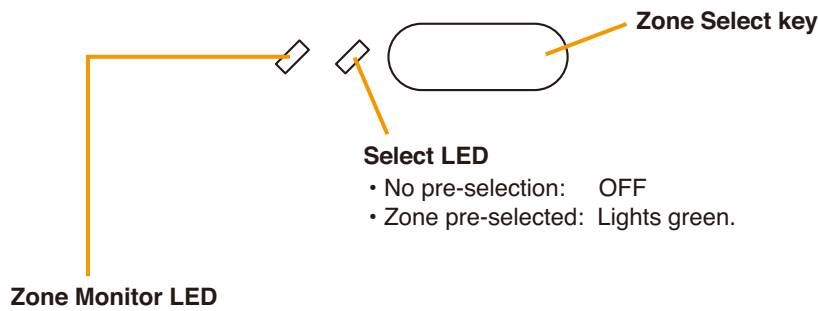

System Status			Zone Monitor LED	
Emergency	Remote Microphone operation	Microphone in use	Lights green.	
	Other Remote Microphone operation	No broadcast	OFF	
		Broadcast made	Other emergency microphone in use	Flashes green.
			Alert EV message currently broadcast	Flashes red.
	Evacuation EV message currently broadcast	Lights red.		
General-purpose	Remote Microphone operation	Microphone in use	Lights green.	
	Other Remote Microphone operation	No broadcast or broadcasting BGM	OFF	
		Broadcast made	Flashes green.	
		Broadcasts made to pre-selected zones from other equipment.	Flashes green.	

### 3.1.11. All-Zone selection

Pre-selects all zones for broadcast.

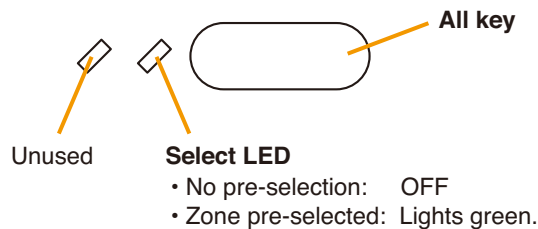

### 3.1.12. Clear

Cancels pre-selections.

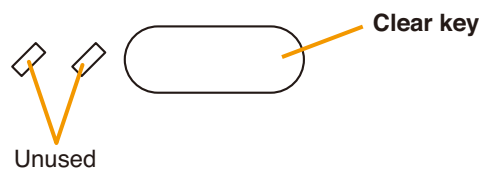

### 3.1.13. Talk

Press the Talk key to make microphone announcements.

- PTT and Lock modes turn the microphone ON or OFF with the use of the Talk key.

Mode	Operation
PTT	The microphone turns on to enable broadcasts while the key is pressed.
LOCK	<ul style="list-style-type: none"> <li>• One touch of the key turns on the microphone to enable broadcasts. The next touch of the key turns off the microphone.</li> <li>• A microphone ON duration of 1 – 20 minutes in 1 minute units can be set if the user forgets to turn off the microphone.</li> </ul>

- Four types of chime tones (ascending 4 tones, descending 4 tones, 2 tones, and a single tone) can be selected individually for use at the microphone ON and OFF operation.

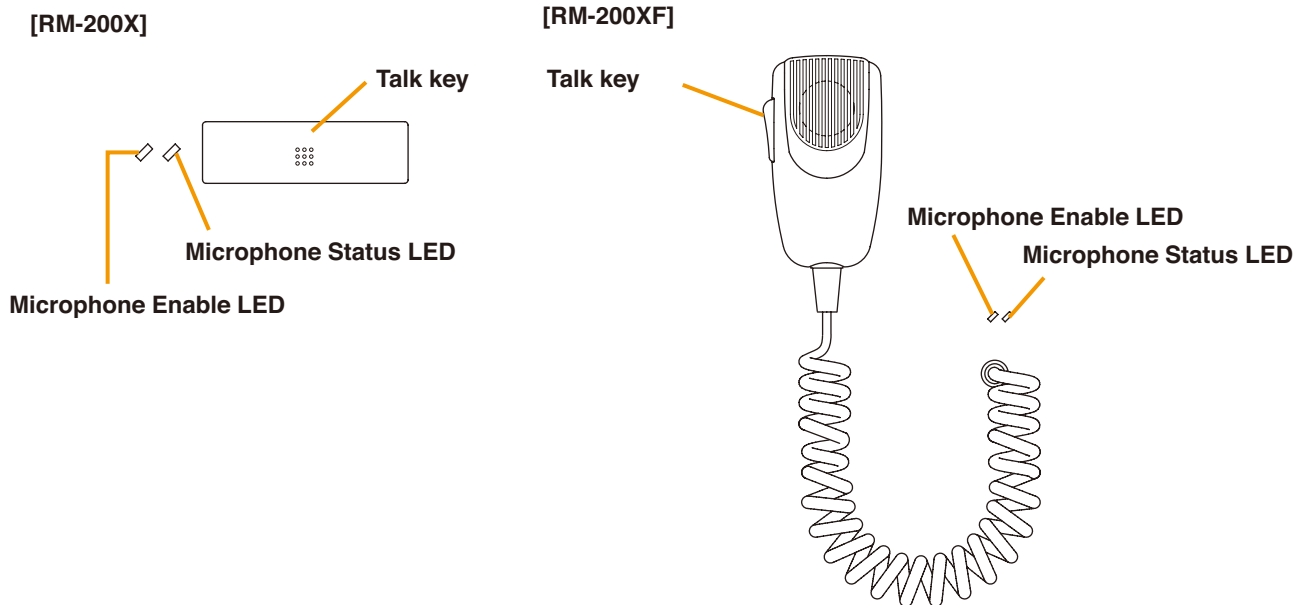

#### Microphone Status LED

- Microphone not in use: OFF
- Chime in progress: Flashes green.
- Microphone in use: Lights green.

#### Microphone Enable LED

System Status				Microphone Enable LED	Broadcast Possible: ✓ Broadcast Impossible: ✗
Pre-selected zones not used by other equipment.				OFF	✓
Broadcasts made to pre-selected zones from other equipment.	Equipment not connected to the same line	Other equipment broadcast priority low.		Flashes green.	✓
		Other equipment broadcast priority high.	All zones	Flashes orange.	✗
	Part of zones		Flashes green.	✓ (Broadcasts can be made to the remaining zones.)	
	Other Remote Microphone connected to the same line	Other Remote Microphone priority high.		Flashes orange.	✗
Other Remote Microphone priority low.		Flashes green.	✓		

### 3.1.14. General-Purpose EV Message

Recalls the general-purpose broadcast EV message.

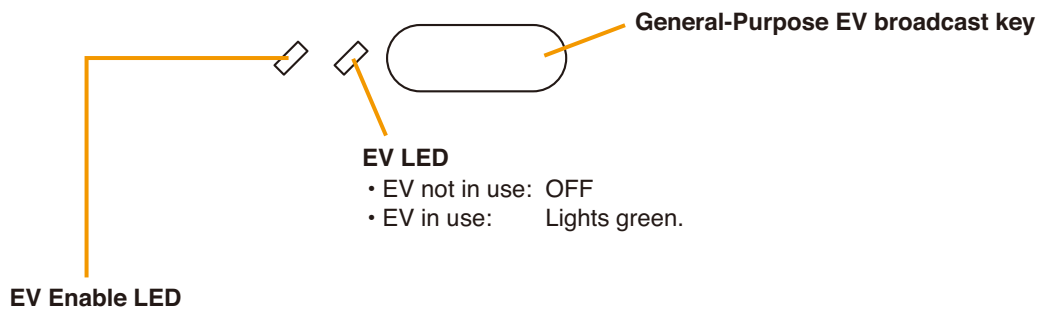

System Status		EV Enable LED	Broadcast Possible: ✓ Broadcast Impossible: ✗
Pre-selected zones not used by other equipment.		OFF	✓
Broadcasts made to pre-selected zones from other equipment.	Other equipment broadcast priority low.	Flashes green.	✓
	Other equipment broadcast priority high.	All zones	Flashes orange. ✗
Part of zones		Flashes green.	✓ (Broadcasts can be made to the remaining zones.)
Message in the same EV being currently broadcast	Priority high.	Flashes orange.	✗
	Priority low.	Flashes green.	✓

### 3.1.15. Chime

The built-in chime can be assigned for broadcast.

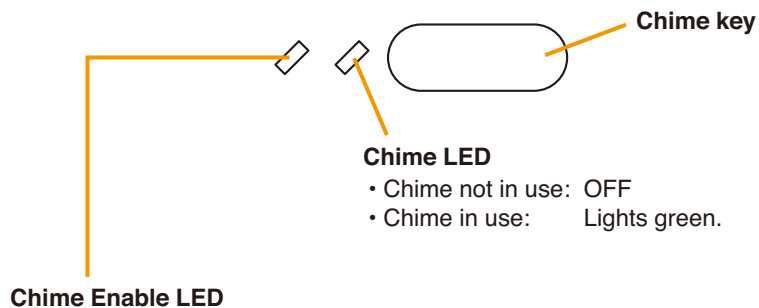

System Status		Chime Enable LED	Broadcast Possible: ✓ Broadcast Impossible: ✗
Pre-selected zones not used by other equipment.		OFF	✓
Broadcasts made to pre-selected zones from other equipment.	Other equipment broadcast priority low.	Flashes green.	✓
	Other equipment broadcast priority high.	All zones	Flashes orange. ✗
Part of zones		Flashes green.	✓ (Broadcasts can be made to the remaining zones.)
Other built-in chime being currently broadcast	Priority high.	Flashes orange.	✗
	Priority low.	Flashes green.	✓

## 3.2. Control Input

Broadcast or control patterns can be recalled by way of external control signals. Functions that can be activated by way of the control input terminal are as follows:

**[Table of functions that can be assigned to the control input]**

Activation Item	Function
Emergency Activation* <sup>1</sup>	Activates Emergency mode. Recalls assigned emergency broadcast patterns for broadcast.
Silence* <sup>2</sup>	The EV message stops.
Emergency Reset	Restores the general-purpose broadcast mode.(Reset EV messages cannot be assigned.)
Interrupt Broadcast Pattern* <sup>1</sup>	Recalls assigned Interrupt broadcast patterns for broadcast.
EV Message Broadcast Pattern* <sup>1</sup>	Recalls assigned EV message broadcast patterns for broadcast.
Base Pattern Change* <sup>1</sup>	Recalls assigned base patterns for broadcast.
Base Pattern End	Stops BGM broadcasts.
Control Output Interlock* <sup>1</sup>	Recalls assigned control output interlock patterns to activate the control output.
Audio Monitoring* <sup>1</sup>	Selects the desired zones to monitor from the VX-2000 monitor output.
Volume UP Operation* <sup>1</sup>	Changes the assigned volume level in relative steps of 3, 6, 9, 12, 15, 18, or 21 dB.
Volume DOWN Operation* <sup>1</sup>	
Failure Output Reception* <sup>1</sup>	Transmitting a control signal after confirming the occurrence of a failure terminates the Remote Microphone buzzer. The failure detection indicator switches from flashing to steady-on status. The control output activated in synchronisation with failure detection can be set.
Failure Output Reset	Resets the failure detection indication.
Clock Adjustment* <sup>1</sup>	Corrects the VX-2000 internal timer setting to the nearest 30 seconds. [Example] If a control signal is received at 00:05:45, the time is adjusted to 00:06:00. If a control signal is received at 00:05:15, the time is adjusted to 00:05:00.
Failure Display Input* <sup>1</sup>	If failure data is received from other system, the failure indicators of the RM-200XF, RM-200X, VX-2000 and VX-2000SF light. Such event is recorded in a log.
External Fault CIN* <sup>2</sup>	Assigns the failure data from the external equipment to the Failure Output Pattern.

\*<sup>1</sup> Activated at the time of system power-on when the corresponding control input is set ON.

\*<sup>2</sup> Available when the VX-2000 Setting Software Version 2.1 or later is installed.

### Notes

- The VX-2000 is equipped with 16 control input terminals. The number of control inputs can be increased by adding the VX-200SI Control Input Module to the VX-2000SF. The number of control inputs can be increased by 16 terminals per VX-200SI up to a total of 128 terminals per system.
- Because both the VX-2000's control input and VX-200SI employ photocouplers, they can be insulated through modification. For the modification procedures, refer to [p. 8-17](#) (VX-2000) or [p. 8-32](#) (VX-200SI).
- The VX-200SI's control inputs are factory-preset to be activated by a "make" signal. This can be changed to "break" signal activation by way of the DIP switch on the circuit board. For the switching procedures, refer to [p. 8-31](#).

### 3.3. Internal Timer

The VX-2000 has an internal timer that enables base patterns to be changed and EV message broadcasts to be made at preset times. Use the PC software to set the timer. For the timer settings, refer to p. 7-58.

#### 3.3.1. Preparing day programs

- Day Programs are basic operating programs. Up to 32 events can be set in 1- minute units per day (24 hours) for each program. Up to 10 Day Programs can be created.
- Events include recalled broadcast/control patterns, or set functions activated at preset times or concurrently during a duration. The following table shows the events that can be programmed into the timer.

#### [Events that can be programmed into the timer]

Event	Function
Interrupt broadcast	Recalls and broadcasts assigned Interrupt broadcast patterns during the duration between set start and end times.
EV message broadcast	Recalls and broadcasts assigned EV broadcast patterns at set times.
Base pattern change	Recalls and broadcasts assigned base patterns at set times.
Base pattern end	Stops BGM play at set times.
Control output interlocking	Outputs assigned control output patterns during the duration between set start and end times.
Volume UP operation	Increases the broadcast volume above the assigned pattern level during the duration between set start and end times. The volume can be increased by 3, 6, 9, 12, 15, 18 or 21 dB.
Volume DOWN operation	Decreases the broadcast volume below the assigned pattern level during the duration between set start and end times. The volume can be decreased by 3, 6, 9, 12, 15, 18 or 21 dB.

#### [Day program setting example]

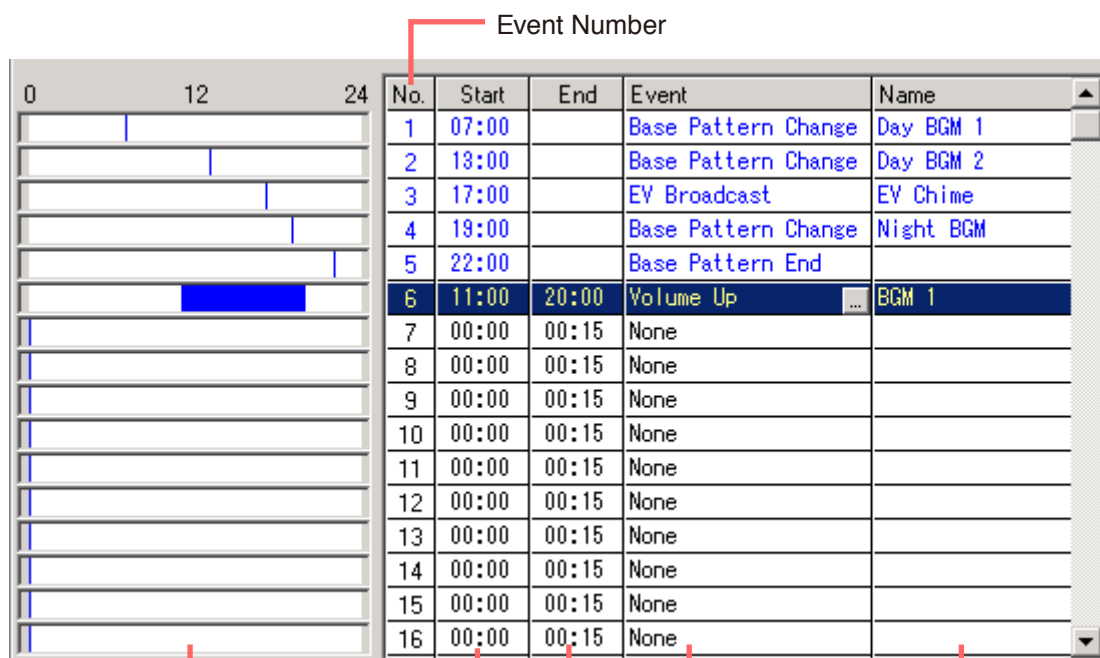

Event Start / End Times

Event

Pattern Names Assigned to Events

### 3.3.2. Timer management

The 2 programs shown below can be used for management:

- **Weekly program**

Assign prepared Day Programs to each day of the week to create Weekly Programs, and repeat the Weekly Programs every week for normal management procedures. (This is the normal way of management.)

[Weekly program setting example]

Weekly Program List

SUN	Weekend
MON	Weekday
TUE	Weekday
WED	Weekday
THU	Weekday
FRI	Weekday
SAT	Weekend

Assign prepared Day Programs to each day of the week.

- **Holiday program**

The same Day Program is operated every day during a set period of time. Two or more Holiday Programs (up to 40 patterns) can also be created as alternate Day Programs.

[Holiday program setting example]

Start Date

End Date

Year Month Day

Year Month Day

Day Program

Summer holidays

Set Day Programs to use during this period of time.

Set start and end dates (year/month/date).

### 3.3.3. Summer time settings

Summer time can be set by using either the Daylight saving switch on the VX-2000 front panel or the PC software. When using the PC software setting, Summer time can be set to automatically switch on for a designated period of time. When the system switches to summer time mode, the internal timer advances by 1 hour.

- **Setting summer time by way of the VX-2000 Daylight saving switch**

The Daylight saving switch is located inside the VX-2000 front panel pocket.

SUMMER TIME position: The internal timer advances by 1 hour regardless of the PC software setting.  
 PC SETTING position: The internal timer is set by the PC software, and advances by 1 hour during the summer time period if so programmed.

**Step 1.** Remove the VX-2000 front pocket panel.

[VX-2000 Front]

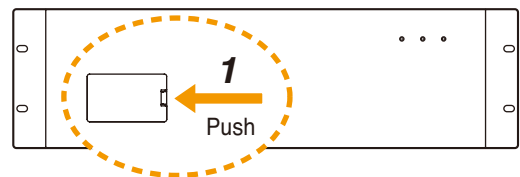

**Step 2.** Loosen the internal screw with a Phillips screwdriver and move the switch cover to set the switch to the SUMMER TIME position.

Daylight saving switch



**Step 3.** Tighten the screw to fix the setting, then replace the front pocket panel.

- **Setting summer time by way of the PC software setting**

Call up the PC software screen and click on the Manual Summer Time Settings checkbox, then set the summer time period. (For the setting procedures, refer to p. 7-62.)

During the set summer time period, the internal timer advances by 1 hour regardless of the VX-2000 Daylight saving switch settings.

[VX-2000 setting software Timer Settings screen]

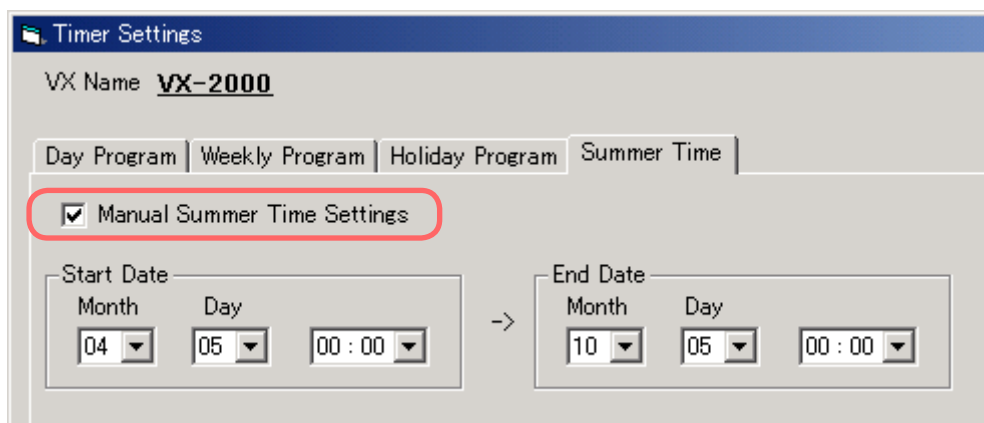

**Notes**

- After the PC software-set summer time period ends, the system automatically returns to standard time. However, if the VX-2000 Daylight saving switch is set to the SUMMER TIME position, the internal timer advances by 1 hour.
- If the PC software's summer time settings remain unchanged, the same period is repeated every year. To change the start/end dates and times, modify the set software data and upload accordingly.

## 3.4. Activation Item Function Table

✓ : Can be set      – : Cannot be set      ✕ : Cannot be used

Mode	Function	Remote Microphone		Control Input	Internal Timer	
		Emergency Type	General Type			
Emergency	Emergency Activation		✓	✓	–	
	Silence*	✓	✕	✓	–	
	Emergency Reset	✓	✕	✓	–	
	EV Alert	✓	✕	–	–	
	EV Evacuation	✓	✕	–	–	
	Control Output	✓	✕	✓	✓	
	Audio Monitoring	✓	✕	✓	–	
	Zone Selection	✓	✕	–	–	
	All-Zone Selection	✓	✕	–	–	
	Clear	✓	✕	–	–	
	Talk	✓	✕	–	–	
	Time Adjustment		–	✓	–	
	Failure Output Reception		✓	✓	–	
	Failure Output Reset		✓	✓	–	
	Lamp Test*		✕	–	–	
	Emergency Ack.*		✓	–	–	
	Password Lock*		✓	–	–	
	External Fault CIN*		–	✓	–	
	General	Base Pattern Change		✓	✓	✓
		Base Pattern End		✓	✓	✓
Control Output			✓	✓	✓	
Audio Monitoring			✓	✓	–	
Volume Up			✓	✓	✓	
Volume Down			✓	✓	✓	
Zone Selection			✓	–	–	
All-Zone Selection			✓	–	–	
Clear			✓	–	–	
Talk			✓	–	–	
General EV			✓	–	–	
Chime			✓	–	–	
Interrupt Broadcast			–	✓	✓	
General EV Broadcast Pattern			–	✓	✓	
Time Adjustment			–	✓	–	
Failure Output Reception			✓	✓	–	
Failure Output Reset			✓	✓	–	
Failure Display Input			–	✓	–	
Lamp Test*			✓	–	–	
Emergency Ack.*			✓	–	–	
Password Lock*		✓	–	–		
External Fault CIN*		–	✓	–		

\* Available when the VX-2000 Setting Software Version 2.1 or later is installed.



# ***Chapter 5***

---

## ***OPERATION***

## 1. OPERATING THE REMOTE MICROPHONE BY USING A PASSWORD

Only powering up the system enables the Remote Microphone operation when no password is set. In this case, the operation procedures described herein are not required.

For password setting, refer to [p. 7-23](#).

Once a password (4-digit one comprised of the numbers 1 – 5) has been set, the Remote microphone cannot be operated without entering the password. The password entry is made with the Remote Microphone's function keys.

The Remote Microphone to which a password is set has its LEDs on the left of Function keys flashed orange indicating standby for password entry.

### 1.1. Entering a Password

Function keys correspond to the numbers 1 – 5 as follows.

[RM-200XF]

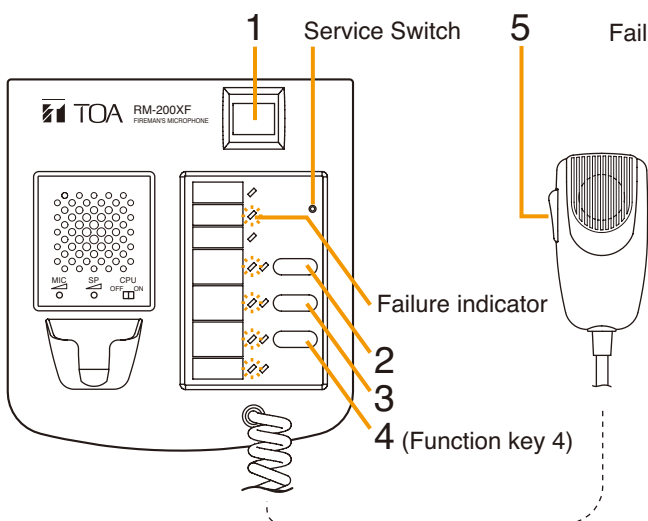

[RM-200X]

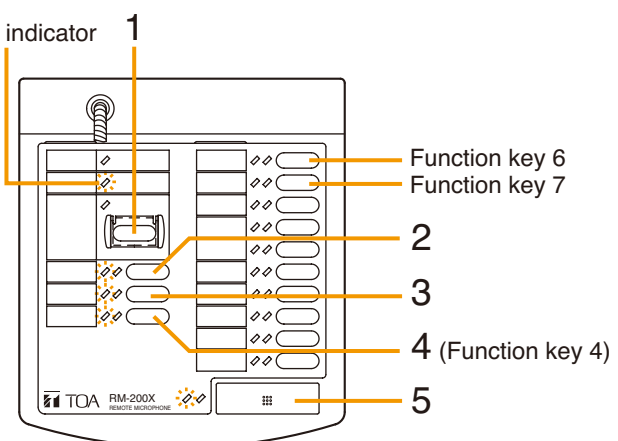

#### [Entering a password when the VX-2000 Setting Software Version 2.1 or later is installed]

Press the Password Lock\* key. The right-side LED (Password Lock LED) located beside this key flashes green. Enter the 4-digit password by pressing the keys corresponding to the above numbers. When the password entered is correct, the Password Lock LED changes to steady green, enabling the Remote Microphone to operate. As the Password Lock LED remains flashing green if the password entered is wrong, enter the correct password after pressing the Password Lock key again.

\* This function must be assigned to the Function key. (Refer to [p. 7-54](#).)

#### [Entering a password when the VX-2000 Setting Software Version 2.0 or earlier is installed]

Enter the 4-digit password by pressing the Remote Microphone's Function keys.

Entering the first to third numbers of a password causes each right LED of the Function keys 2 – 4 to light up green in order regardless of whether the entered password numbers of up to third digit are correct or not.

Entering the last (fourth) number enables the Remote Microphone's operation if the password entered is correct. However, if it is wrong, the unit operation returns to the password entry status at this time.

**Tip:** If you forget the password, set a password in the System Setting File again and download its file to the Remote Microphone.

### 1.2. Bringing the Remote Microphone into Password Entry Status

#### [When the VX-2000 Setting Software Version 2.1 or later is installed]

If the set timeout period expires without key operation in Remote Microphone's operation enabled condition, the Remote Microphone is automatically placed in the status it cannot be operated without entering password. Also it is possible to place the Remote Microphone in the Password Entry status by pressing the Password Lock key in Remote Microphone's operable status.

#### [When the VX-2000 Setting Software Version 2.0 or earlier is installed]

The Remote Microphone can be placed in the Password Entry status by resetting the Remote Microphone. For resetting method, refer to [p. 2-5](#) for RM-200XF and [p. 2-7](#) for RM-200X.

**Tip:** Returning the unit operation to this status cancels all pre-selections for zone broadcast.

## 2. EMERGENCY BROADCASTS

Emergency broadcasts are broadly divided into two types: Emergency EV message (Alert and Evacuation messages) broadcast and Emergency Remote Microphone (RM-200XF and RM-200X) broadcasts.

- Emergency EV message broadcasts include dual-origin EV broadcasts and single-origin EV broadcasts, depending on the number of EV-200 units installed in the VX-2000.
- Set an emergency broadcast pattern consisting of an emergency EV message and corresponding broadcast zones, and assign the set pattern to the Remote Microphone's function key or control input. When the emergency mode is activated by way of the Emergency activation button or a control signal from the fire alarm system, the assigned emergency broadcast pattern is recalled and used for the broadcast.
- Use the PC software to set the emergency broadcast pattern (refer to p. 7-39) and assign it to the control input or Remote Microphone (refer to p. 7-52).

### 2.1. Dual-Origin EV Message Broadcast

Here, explanations are given to the system in a department store as an example.

[Internal wiring]

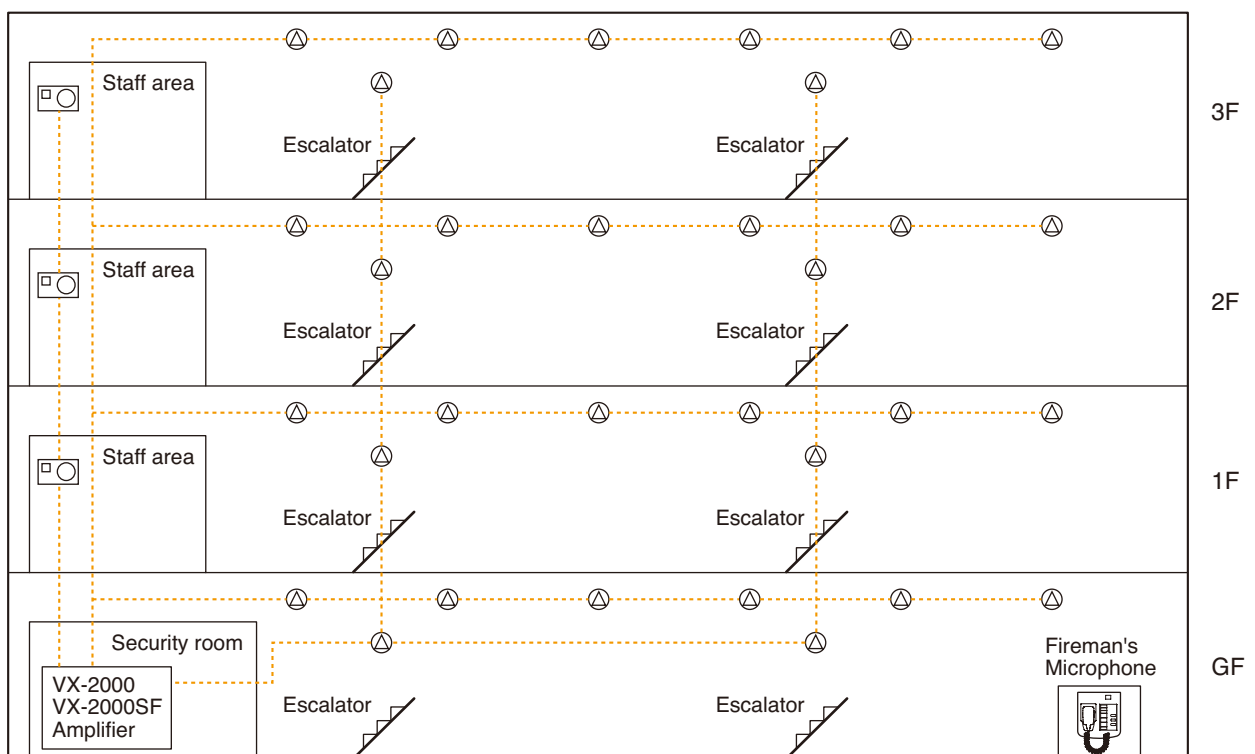

[Block diagram]

- The key factor in this system application is simultaneous broadcast.
- BGM sound is broadcast from a CD player.

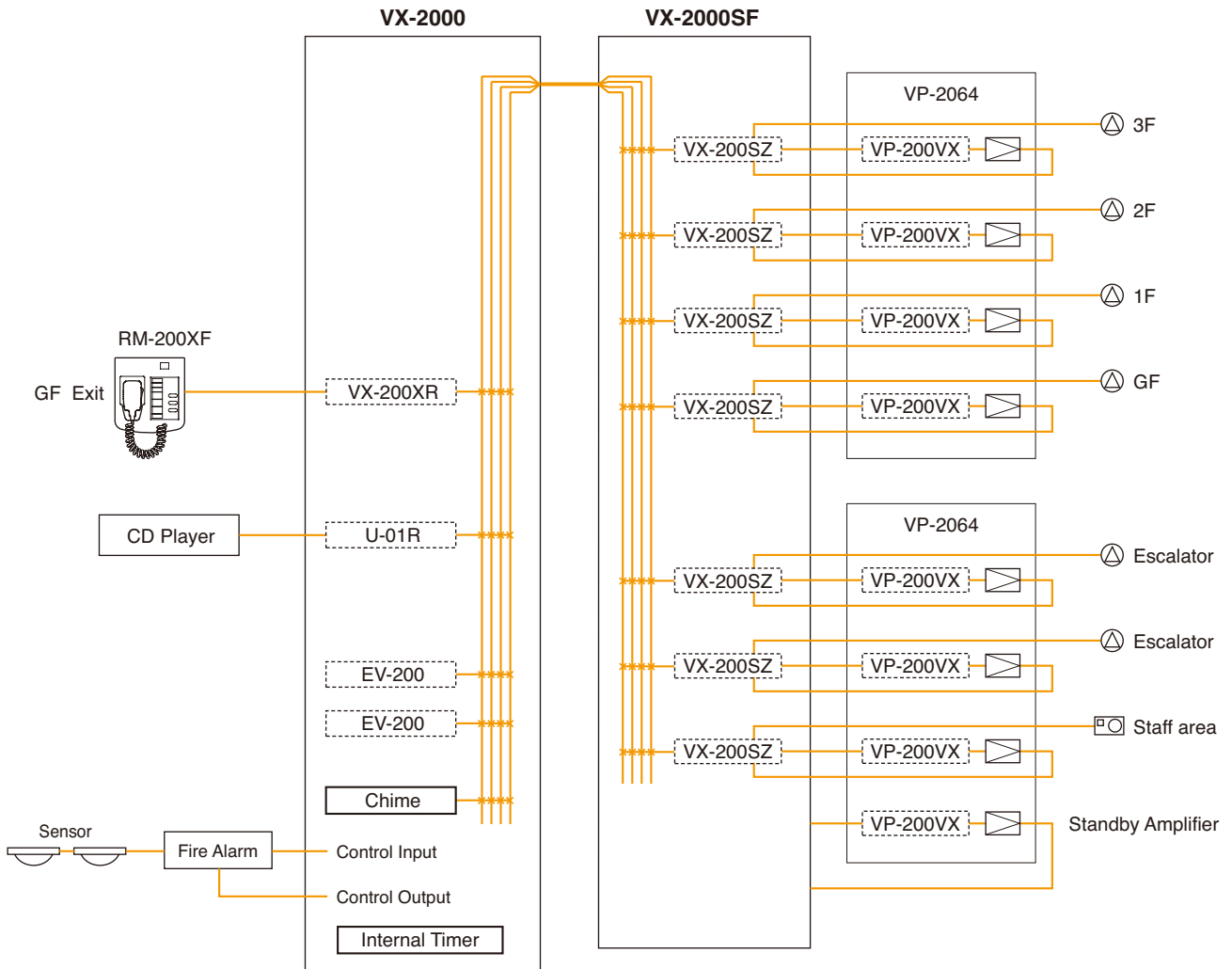

**Note:** The chime unit and the internal timer are pre-installed in the VX-2000.

In the following example, 2 EV-200 units are installed in the VX-2000 to provide dual-origin Emergency broadcasts. Different messages can be simultaneously broadcast to individual zones with the use of 2 EV units. An Alert message is recorded in EV-1, and an Evacuation message is recorded in EV-2.

**[Alert and evacuation message examples]**

Alert Message:           The fire alarm system has been engaged. We are now checking the cause.  
                              Please wait for further information.

Evacuation Message: There is a fire. Please evacuate immediately.

**[Pattern setting]**

Up to 50 Emergency broadcast patterns can be set for each of Alert and Evacuation messages when 2 EV-200 units are used. The created patterns are assigned to the Remote Microphone's emergency button or control inputs. Activating the Emergency mode or receiving a fire alarm signal recalls the assigned pattern and broadcasts the message to the set zones.

Assuming that Emergency broadcast patterns are set as follows:

- The broadcast zones and broadcast duration depend on control signals received from the connected fire alarm system. (Pattern 1 – 10)
- Buttons to activate the Evacuation message broadcast are configured in all zones. (Pattern 11)

Emergency Broadcast Pattern	Setting Contents
1	Alert message broadcast to GF
2	Alert message broadcast to 1F
3	Alert message broadcast to 2F
4	Alert message broadcast to 3F
5	Alert message broadcast to escalators and staff areas
6	Evacuation message broadcast to GF
7	Evacuation message broadcast to 1F
8	Evacuation message broadcast to 2F
9	Evacuation message broadcast to 3F
10	Evacuation message broadcast to escalators and staff areas
11	Evacuation message broadcast to all zones

**Step 1.** In general-purpose broadcast mode, BGM is broadcast to the entire building area.

🔊 BGM	3F
🔊 BGM	2F
🔊 BGM	1F
🔊 BGM	GF

General-purpose broadcast mode

**Step 2.** A fire has broken out on 2F. A sensor detects it and the connected fire alarm system transmits a control signal to the VX-2000's Control Input. The Emergency mode is activated, and BGM play is interrupted. Emergency broadcast pattern 3 is recalled, and the Alert message (EV-1) is broadcast to warn the people on 2F.

Emergency activation by the fire alarm system

	3F
🔊 Alert	2F
	1F
	GF

[EV-1]

Alert message (2F)

[EV-2]

No broadcasting zone

*Continued on next page*

**Step 3.** Three minutes after the Emergency mode was activated, the fire alarm system automatically transmits a control signal to the Control Input, changing the broadcast zones and messages. Emergency broadcast patterns 1, 2, 8, 9, and 10 are recalled, and the Evacuation message (EV-2) is broadcast to 2F, 3F, escalators, and staff area, while the Alert message (EV-1) is broadcast to GF and 1F to provide warning of the detected fire.

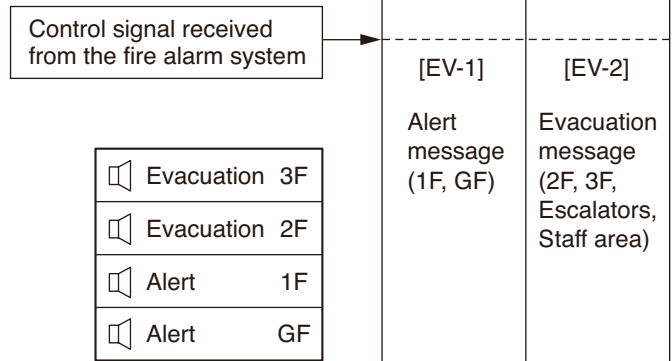

**Step 4.** Since the fire has not been extinguished, a decision is made to press the fire button to call all zones for immediate evacuation. Pressing the button transmits a control signal to the VX-2000, recalling Emergency broadcast pattern 11 and broadcasting the Evacuation message (EV-2) to all zones.

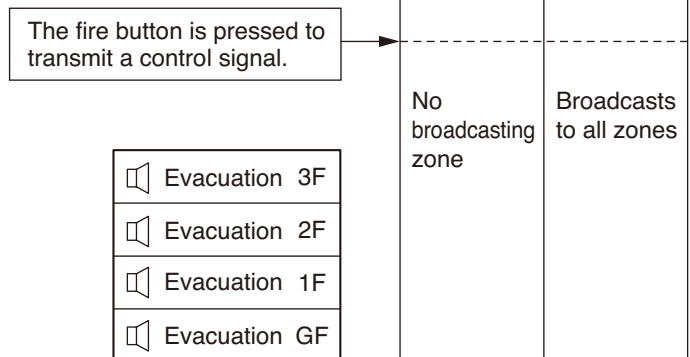

**Step 5.** Once the fire has been brought under control, the fire alarm system automatically transmits a reset control signal to the Control Input. The Emergency broadcast mode is terminated, and general-purpose broadcasting is resumed, restoring the original BGM output.

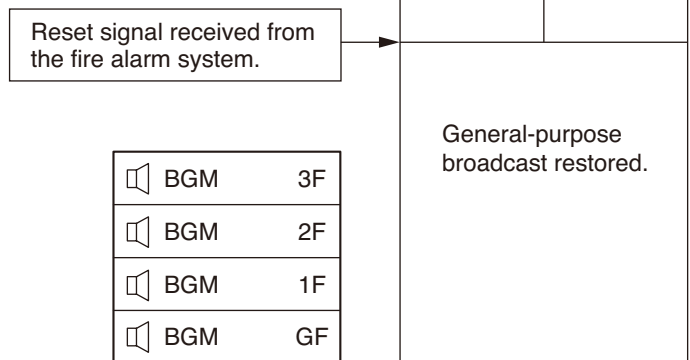

## 2.2. Single-Origin EV Message Broadcast (Sequential Operation)

Here, explanations are given to the system in a hotel as an example.

### [Internal wiring]

Speaker arrangements and their wiring in Building are as shown in the figure below.

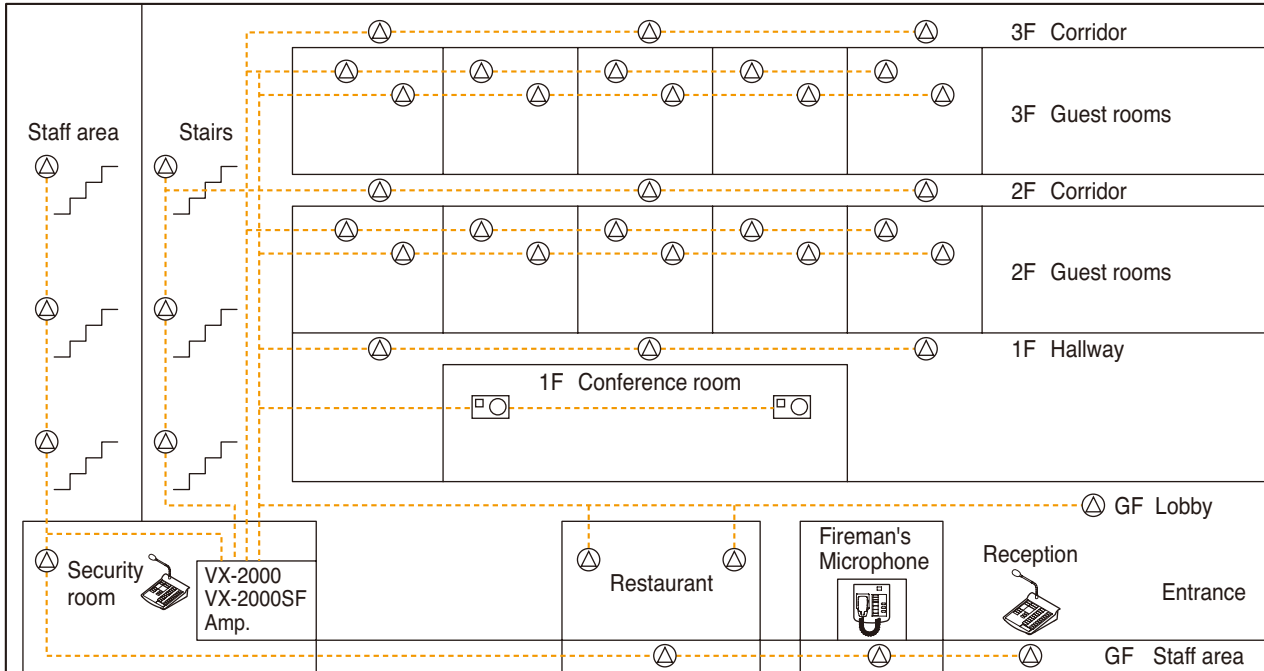



**[Block diagram]**

The system's block diagram is shown below.

**Note:** Guest rooms 1 and 2 represent dual speaker lines of an interleaved speaker system provided for each guest room as fail safe system.

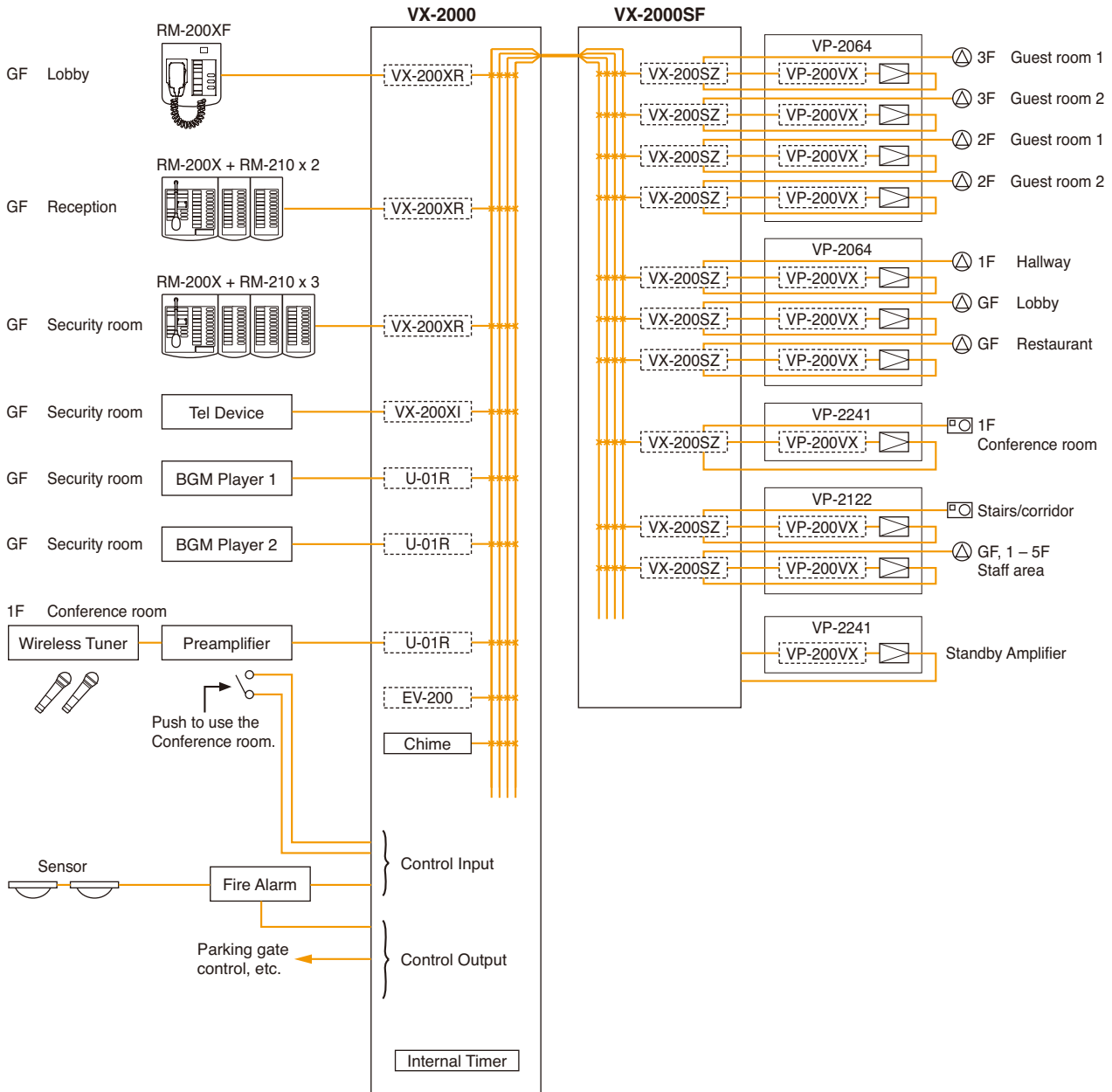

Here, an example of sequential operation with an EV-200 mounted in the VX-2000 is explained. Single-origin EV broadcasts permit EV messages and their corresponding broadcast zones to be changed by switching sequential operations between Phase 1 and Phase 2 when set time intervals elapse.

**[Sequential operation]**

Sequential operation consists of Phase 1 and Phase 2.

Sequence Phase 1 operates upon emergency system activation. When the set time interval elapses, the broadcast is automatically switched to Phase 2.

Only one sequence consisting of Phase 1 and 2 broadcast messages and sequence switching time interval can be set per system.

Assuming that these phases are set as follows:

**Phase 1:** The alert message is continuously broadcast for 5 minutes.

**Phase 2:** The evacuation message is continuously broadcast.

**[Pattern setting]**

Up to 50 Emergency broadcast patterns can be set for each of Phase 1 and Phase 2 broadcast zones when 1 EV-200 unit is used. The created patterns are assigned to the Remote Microphone's emergency button or control inputs. Activating the Emergency mode or receiving a fire alarm signal recalls the assigned pattern and broadcasts the message to the set zones.

Assuming that Emergency broadcast patterns are set as follows:

Emergency Broadcast Pattern	Broadcast Zone Setting
1	Phase-1: GF Phase-2: ALL Zones
2	Phase-1: 1F Phase-2: ALL Zones
3	Phase-1: 2F Phase-2: ALL Zones
4	Phase-1: 3F Phase-2: ALL Zones

**Step 1.** Background music (BGM) is broadcast to GF and 1F when the system is in general-purpose broadcast mode.

	3F
	2F
🔊 BGM	1F
🔊 BGM	GF

General-purpose broadcast mode

**Step 2.** The sensor installed on 2F detects irregularities, and the fire alarm system transmits a control signal to the control input. The emergency mode is activated and BGM stops. Emergency broadcast pattern 3 is recalled, allowing the alert message to be played through to 2F.

Emergency activation signal →

	3F
🔊 Alert	2F
	1F
	GF

Emergency sequence Phase 1

5 minutes

Continued on next page

**Step 3.** Following this, the sensors installed on 1F and 3F detect irregularities and the fire alarm system transmits a control signal to the control input. Emergency broadcast patterns 2 and 4 are also recalled in addition to pattern 3, and broadcast zones are added, and the alert message is also broadcast to 1F and 3F, as well.

**Step 4.** After the set 5-minute time interval elapses, the message is automatically switched from Phase 1 to Phase 2. Broadcast zones change to the "entire zone" and the evacuation message is broadcast to the entire area. The evacuation announcement continues until the Remote Microphone's reset key is pressed or a reset signal is transmitted from the connected fire alarm system.

**Step 5.** The fire alarm system transmits a reset control signal to the control input. The emergency mode is terminated and the broadcast reverts to general-purpose broadcast mode, restoring BGM output.

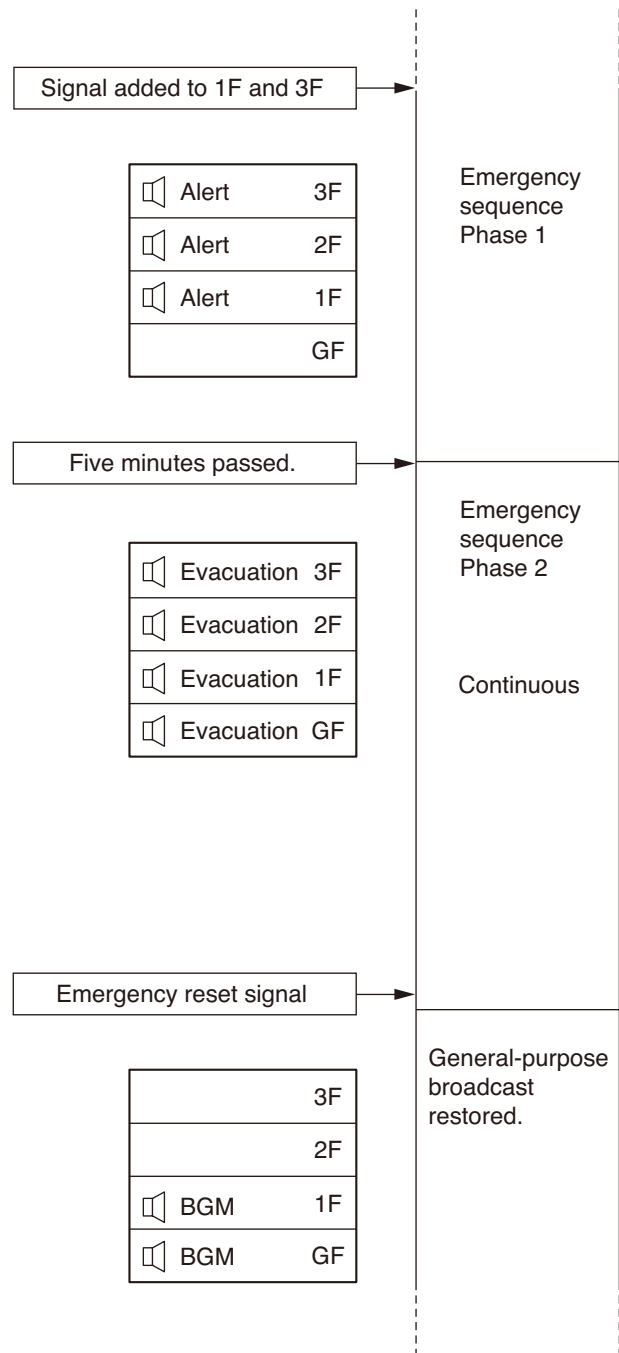

### 2.3. Emergency Mode Activation and Reset

The emergency mode can not only be activated and restored from the connected fire alarm system, but also from any Remote Microphone set for emergency operation.

**Note**

It is possible to activate the emergency mode from the Remote Microphone set for general-purpose use. However, the microphone can no longer be used until the general-purpose broadcast mode is restored.

Here, the settings of the Fireman's Microphone RM-200XF installed on GF are used as an example to explain the flow from emergency mode activation to its cancellation.

**[Setting contents of Fireman's Microphone RM-200XF]**

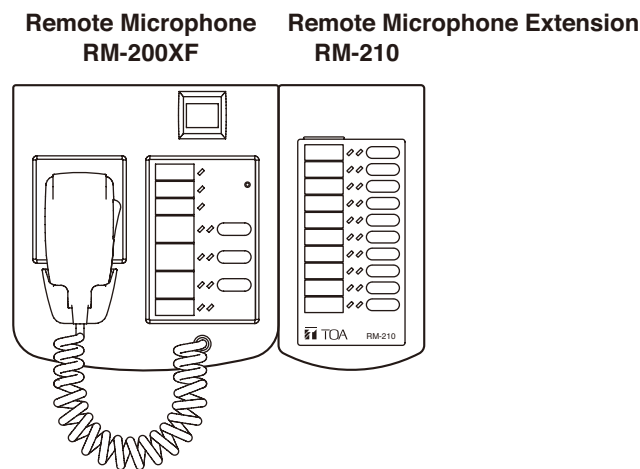

Their function key settings are as follows:

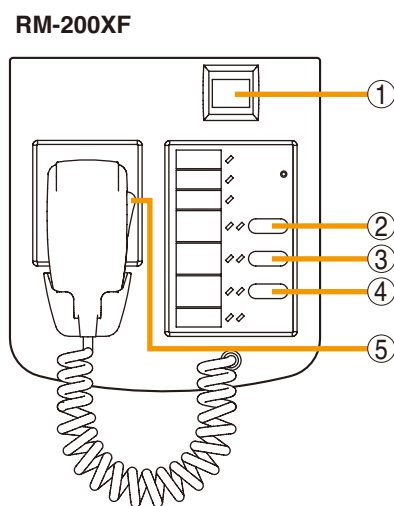

Key	Setting	Function
①	Emergency Activation	Activates emergency mode and recalls emergency patterns. [Pattern setting contents] Phase 1: Alert EV message; all zones; 5 minutes Phase 2: Evacuation EV message; all zones; continuous
②	Evacuation EV	Recalls and broadcasts evacuation EV message.
③	Emergency Reset (Reset EV message)	Broadcast is restored from emergency to normal (general-purpose) broadcast mode after Reset EV message announcement completion.
④	All-Zone Call	Selects all zones.
⑤	Press-to-Talk	Makes microphone announcements.

RM-210

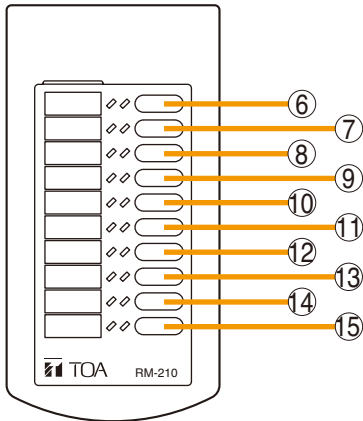

Key	Setting	Function
⑥	GF Zone Select	Zone selection  [General-purpose broadcast mode] • The left-side LEDs are used to monitor zones. · OFF: The zone not used or broadcasting BGM. · Green: Remote Microphone in use · Flashing Green: Other connected equipment (Remote Microphone, EV unit, chime, etc.) in use • The right-side LEDs light green during zone pre-selection.  [Emergency broadcast mode] • The left-side LEDs indicate the type of EV message. · OFF: No broadcast output · Green: Microphone announcement · Red: Evacuation message broadcast · Flashing Red: Alert message broadcast · Flashing Green: Other Remote Microphone in use • The right-side LEDs light green during zone pre-selection.
⑦	1F Zone Select	
⑧	2F Zone Select	
⑨	3F Zone Select	
⑩	Alert Message	Emergency EV message call
⑪	Emergency Reset Message	
⑫	Clear	Cancels all zone selections.
⑬	None	No function assigned.
⑭	None	No function assigned.
⑮	None	No function assigned.

## (1) From Emergency Mode Activation to Reset

Described below are the steps of system operation from emergency mode activation to reset.

### Step 1. Activate emergency broadcast mode.

Press the Emergency Activation button ①.

- Emergency mode is activated and the Emergency Activation button lights red.
- The pre-configured emergency sequence pattern is recalled, and the Alert EV Message is broadcast to all zones.
- Because the alert message is set for broadcast to all zones, the Select LED lights green.

Emergency Activation button ①

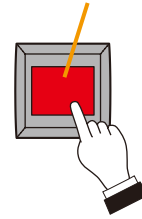

All-Zone Call key ④

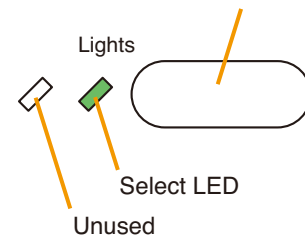

### Step 2. Press the Evacuation EV key ② to broadcast the Evacuation EV message, if necessary.

#### 2-1. Broadcasting EV messages to the entire zone.

When the emergency mode is activated, all zones are automatically pre-selected. The Evacuation EV message will be broadcast to all zones, and the EV Broadcast LED lights green.

Evacuation EV key ②

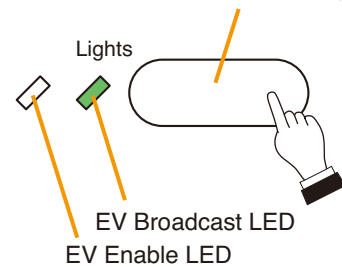

*Continued on next page*

**2-2. Broadcasting EV messages to selected zones.**

Because all zones are pre-selected when in emergency mode, press the All-Zone Call key ④ to cancel the all-zone pre-selection. The zone selection is reset and the Select LED extinguishes.

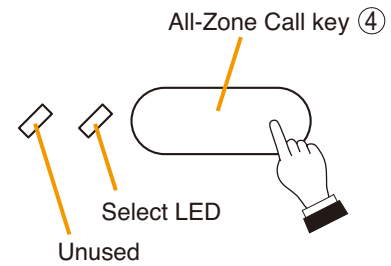

When, for instance, broadcasting the Evacuation EV message to 2F, press the 2F Zone Select key ⑧ to select the zone. The Select LED lights green. Because the Alert EV message is currently being broadcast, the Zone Monitor LED flashes red.

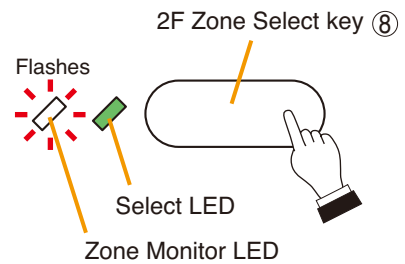

Press the Evacuation EV key ②. The Evacuation EV message is broadcast to 2F, and the EV Broadcast LED lights green.

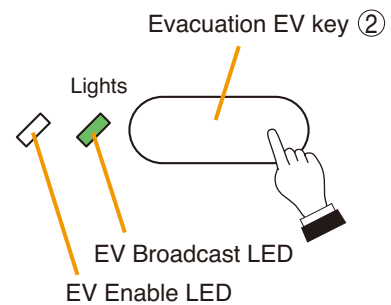

The Zone Monitor LED of the 2F Zone Select key indicates the type of EV message currently being broadcast. It changes from flashing red to steady red status to indicate that the evacuation message is being broadcast.

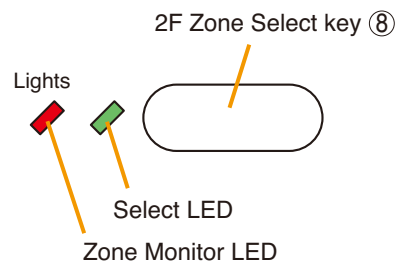

**Tips**

- The Emergency Sequence function automatically switches the current message to the Evacuation EV message after a 5-minute interval if nothing is done.
- To add broadcast zones for the Evacuation EV message, select desired zones with the Zone Select keys and press the Evacuation EV key.
- To stop broadcasting the Evacuation EV message, cancel all the selected zones and press the Evacuation EV key.

*Continued on next page*

**Step 3.** If necessary, press the Talk key ⑤ to make announcements from the Fireman's Microphone.

Because the Remote Microphone set for emergency operation is given the highest priority, evacuation guidance messages can be broadcast from the Fireman's Microphone even during EV message broadcast.

**Note**

In Emergency mode, the talk key performs PTT (press-to-talk) operation regardless of PC software setting.

**3-1.** When making microphone announcements over all zones

- Because all zones are pre-selected when in emergency mode, announcements made from the Remote Microphones are broadcast to the entire zone.
- Because the Alert EV message is currently being broadcast, the left-side Microphone Enable LED flashes green to indicate that priority of current broadcast is lower than that of microphone announcements.
- The right-side LED indicates the status of microphone usage. It lights green when the Talk key is pressed.

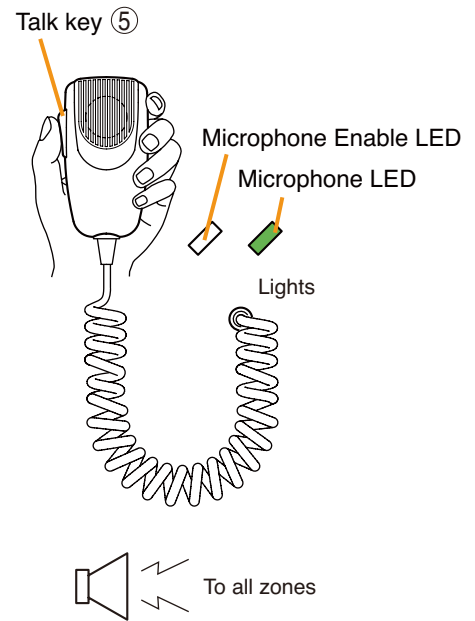

**3-2.** When making microphone announcements to selected zones

- Because all zones are pre-selected when in emergency mode, press the All-Zone Call key ④ to cancel the all-zone pre-selection. The zone selection is reset and the Select LED extinguishes.

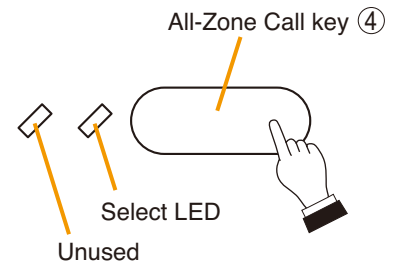

- Assuming that microphone announcements are broadcast to 3F, the corresponding Zone Monitor LED is flashing red because the Alert message is being broadcast to 3F. Press the 3F Zone Select key ⑨ to select the zone. The Select LED lights green.

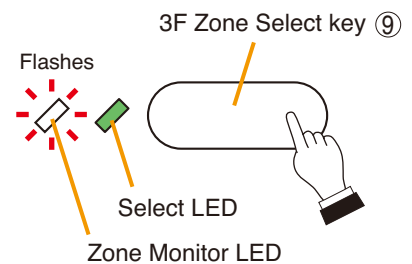

*Continued on next page*



- Because the Alert EV message is currently being broadcast, the left-side Microphone Enable LED flashes green, indicating that broadcasts with priority lower than that of microphone announcements are in progress.
- The right-side LED indicates the status of microphone usage. It lights green when the Talk key is pressed.
- Speaking into the microphone after pressing the Talk key causes the Microphone LED to light green and permits announcements to go through to 3F.
- The Zone Monitor LED of the 3F Zone Select key lights green when announcements are made from the microphone.

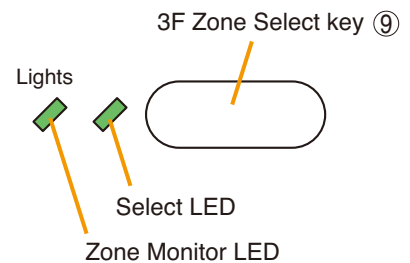
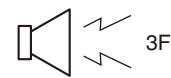
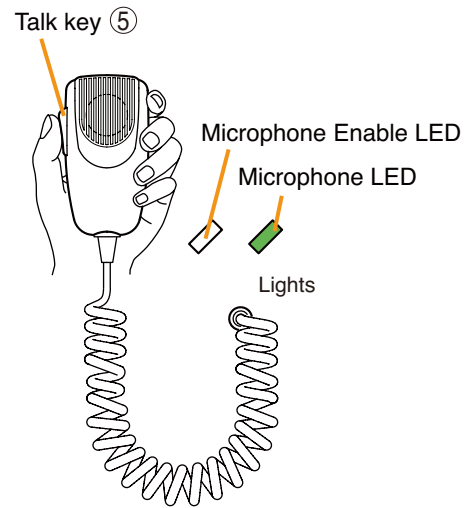

**Tip**

When a Fireman's Microphone announcement interrupts an EV message broadcast, the broadcast mode that follows Fireman's Microphone announcement completion can be set to either "Continue" for continuous EV message broadcast or "Silent" for broadcast termination. This setting can be made by way of the connected PC. For details, refer to [p. 7-40](#).

**Step 4. Reset the emergency broadcast mode.**

Press the Emergency Reset key ③.  
After the Reset EV message has been broadcast to the entire area, the system is restored to general-purpose broadcast mode.

**Note**

The Reset EV message is broadcast only to the zones to which the emergency EV broadcast was made.

The Emergency Activation button light extinguishes to indicate that the system is in general-purpose broadcast mode.

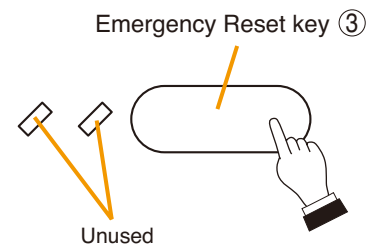

**(2) Making a microphone reset announcement after returning to general-purpose broadcast mode by pressing the Emergency Reset key.**

To use a microphone to make announcements in general-purpose broadcast mode, the broadcast zone needs to be selected. In this example, the broadcast is made to all zones.

**Step 1.** Press the All-Zone Call key ④.

All zones will be pre-selected, and the Select LED will light green.

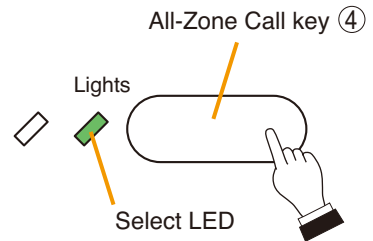

**Step 2.** Press the Talk key ⑤ to make announcements.

The right-side Microphone LED lights green.  
The announcements are broadcast to the entire zone.

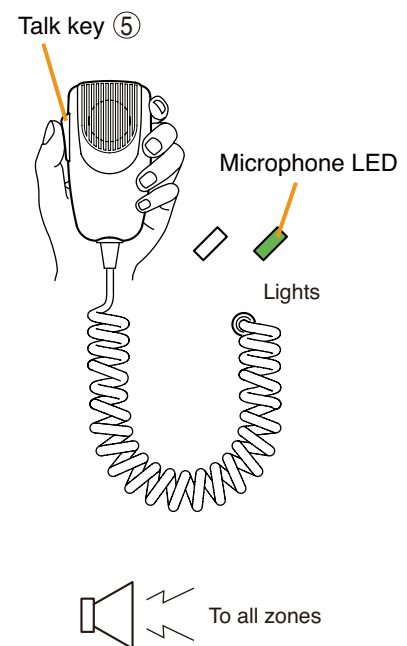

### 3. GENERAL-PURPOSE BROADCAST

Basic operations and indications related to the general-purpose broadcast mode are explained here based on the settings of the Remote Microphone RM-200X installed at the GF reception desk.  
In this example, the RM-200X is set for general-purpose broadcast type.

#### [GF reception desk Remote Microphones settings]

A set of the RM-200X and 2 RM-210 units is installed at the GF reception desk.

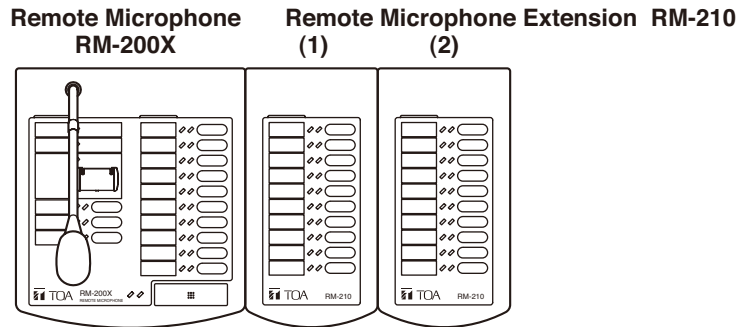

Their function key settings are as follows:

RM-200X

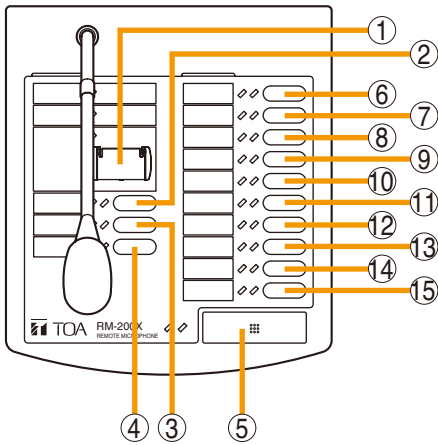

RM-210 (1)

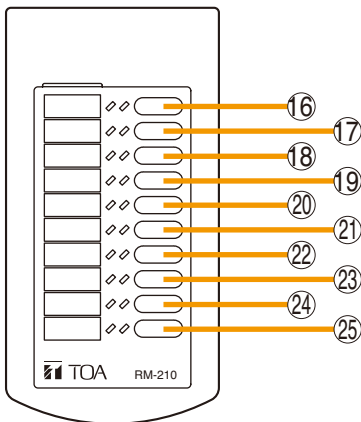

Key	Setting	Function
①	None	No function assigned
②	EV Message 1	Recalls individual EV messages.
③	EV Message 2	
④	All-Zone Call	Pre-selects all zones.
⑤	Talk with 2 Tone Chime	Makes microphone announcements.
⑥	3F Guest rooms	Pre-selects individual zones.
⑦	2F Guest rooms	
⑧	1F Conference room	
⑨	1F Hallway	
⑩	GF Restaurant	
⑪	GF Lobby	
⑫	Stairs / corridor	
⑬	Staff area	Pre-selects a zone group of 1F Hallway, GF Restaurant, GF Lobby, and Stairs/corridor.
⑭	Public zones	
⑮	No BGM	Stops BGM broadcast.
⑯	BGM Pattern 1	Recalls individual base patterns.
⑰	BGM Pattern 2	
⑱	BGM 1 Volume Up	Increases BGM-1 input level.
⑲	BGM 1 Volume Down	Decreases BGM-1 input level.
⑳	BGM 2 Volume Up	Increases BGM-2 input level.
㉑	BGM 2 Volume Down	Decreases BGM-2 input level.
㉒	1F Conference room Volume Up	Increases 1F conference room zone output level.
㉓	1F Conference room Volume Down	Decreases 1F conference room zone output level.
㉔	1F Hallway Volume Up	Increases 1F hallway zone output level.
㉕	1F Hallway Volume Down	Decreases 1F hallway zone output level.

RM-210 (2)

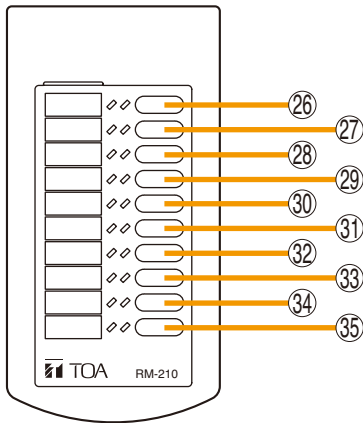

Key	Setting	Function
②⑥	GF Restaurant Volume Up	Increases GF restaurant zone output level.
②⑦	GF Restaurant Volume Down	Decreases GF restaurant zone output level.
②⑧	GF Lobby Volume Up	Increases GF lobby zone output level.
②⑨	GF Lobby Volume Down	Decreases GF lobby zone output level.
③①	Staff Area Volume Up	Increases staff area zone output level.
③②	Staff Area Volume Down	Decreases staff area zone output level.
③③	Stairs / corridor Volume Up	Increases stair and corridor zone output levels.
③④	Stairs / corridor Volume Down	Decreases stair and corridor zone output levels.
③⑤	Public Zone Volume Up	Increases public zone output levels.
③⑥	Public Zone Volume Down	Decreases public zone output levels.

### 3.1. Making Announcements from the Remote Microphone

Assuming that paging broadcasts are made to public zones:

**Step 1.** Press the Public Zones key ⑭ to pre-select the zones.

The zones are pre-selected and the Select LEDs light green.

Because the Public Zones key is assigned a zone group of 1F Hallway, GF Restaurant, GF Lobby, and Stairs/corridor, all the SELECT LEDs of grouped zones also light green when the key is pressed.

The SELECT LEDs remain lit green during pre-selection.

The Zone Monitor LED indicates the zone broadcast status as follows regardless of whether the zone is pre-selected or not.

- OFF: The zone not used or broadcasting BGM
- Green: Remote Microphone in use
- Flashing Green: Other connected equipment (Remote Microphone, EV unit, chime, etc.) in use

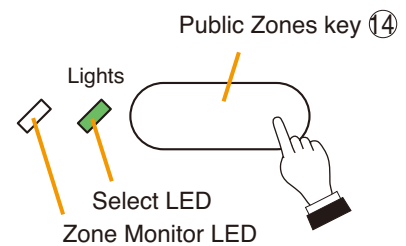

Continued on next page

**Step 2.** Make announcement while holding down the Talk key ⑤ .

Since a 2-tone chime function is provided, a chime tone sounds as soon as the Talk key is pressed.

While sounding, the chime tone is heard from the monitor speaker, and the right-side LED flashes green.

Make the announcement after the LED has switched from flashing to steady on. (The Talk key is assumed to have been set to be a press-to-talk type.)

**Tip**

Two different modes can be set for the Talk key: PTT and Lock modes. Settings can be performed using PC software.

- PTT: Microphone broadcasts remain turned on as long as the key is pressed.
- Lock: Pressing the key turns on microphone announcements, and pressing it again turns them off. It is possible to limit the announcement time with a programmed timer in case the user forgets to turn off the microphone.

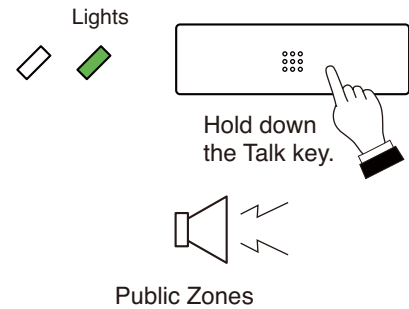
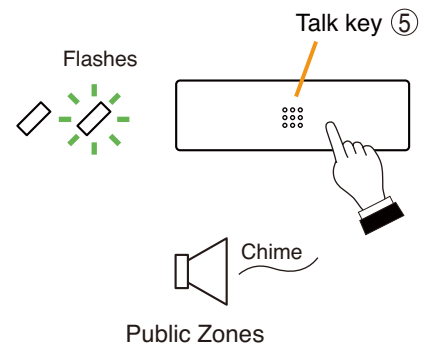

**Tips**

The 2 LEDs located next to the Talk key indicate the following.

- The left-side LED indicates whether microphone announcements can be made to the pre-selected zone.
  - OFF: The zone is free and microphone announcement is possible.
  - Flashing Green: Microphone announcements are possible because currently broadcasting equipment priority is lower.
  - Flashing Orange: Microphone announcements are impossible because currently broadcasting equipment priority is higher.
- The right-side LED indicates microphone usage status.
  - OFF: The microphone is not in use.
  - Green: Microphone announcement is now being made.
  - Flashing Green: Chime tone is now sounding.
- When all broadcasting zones from a Remote Microphone are interrupted by a higher priority broadcast, this causes the Remote Microphone to sound a brief peep and flash the Microphone Enable LED to disable broadcasting microphone announcements.

### 3.2. Making BGM Broadcasts

To broadcast BGM, assign base patterns consisting of BGM sources and their corresponding broadcast zones to the Remote Microphone's function key or control input, then recall such patterns. Base patterns can be switched at preset times by programming times and base patterns into the internal timer.

**[Base pattern setting example]**

No.	Name	Activation Item	Setting Contents
1	Day BGM 1	Timer	BGM 1 : GF Restaurant, GF Lobby BGM 2 : Stairs/corridor, 1F Hallway
2	Day BGM 2		BGM 1 : Stairs/corridor, 1F Hallway BGM 2 : GF Restaurant, GF Lobby
3	Night BGM		BGM 1 : GF Restaurant, Stairs/corridor, 1F Hallway, GF Lobby
4	BGM Pattern 1	RM	BGM 1 : GF Restaurant, GF Lobby, 1F Conference room BGM 2 : Stairs/corridor, 1F Hallway
5	BGM Pattern 2		BGM 1 : Stairs/corridor, 1F Hallway BGM 2 : GF Restaurant, GF Lobby, 1F Conference room

#### 3.2.1. Recalling base patterns using the internal timer

By programming times and base patterns into the internal timer, BGM broadcasts can be changed at preset times.

**[Setting example]**

No.	Start	End	Event	Name
1	09:00		Base Pattern Change	Day BGM 1
2	12:00		Base Pattern Change	Day BGM 2
3	18:00		Base Pattern Change	Night BGM
4	22:00		Base Pattern End	
5	00:00	00:15	None	
6	00:00	00:15	None	
7	00:00	00:15	None	
8	00:00	00:15	None	
9	00:00	00:15	None	
10	00:00	00:15	None	
11	00:00	00:15	None	
12	00:00	00:15	None	
13	00:00	00:15	None	
14	00:00	00:15	None	
15	00:00	00:15	None	
16	00:00	00:15	None	

[Example for the programmed base patterns]

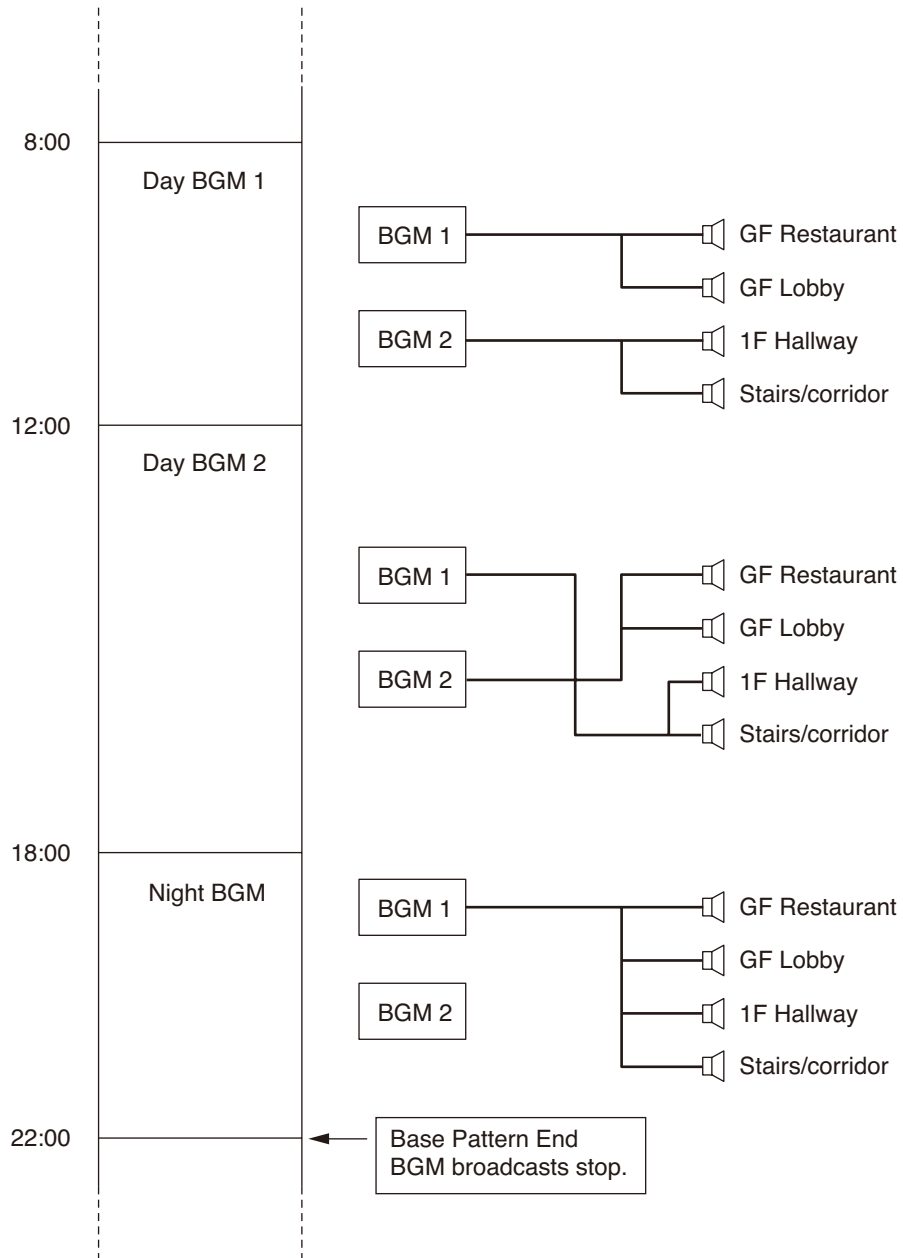

### 3.2.2. Recalling base patterns from the Remote Microphone

Supposing that the Remote Microphone's keys ⑩ and ⑪ are set as follows:

Key	Setting	Function
⑩	BGM Pattern 1	BGM 1 output to the 1F Conference Room in addition to the originally set zone.
⑪	BGM Pattern 2	BGM 2 output to the 1F Conference Room in addition to the originally set zone.

**Step 1.** Press the BGM Pattern 1 key ⑩ to additionally broadcast BGM 1 to the 1F Conference Room.

The Base Pattern Status LED lights green to indicate that the "BGM Pattern 1" base pattern is in use.

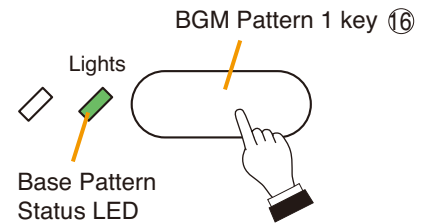

**Step 2.** Press the BGM Pattern 2 key ⑪ to additionally broadcast BGM 2 to the 1F Conference Room.

The Base Pattern Status LED for BGM Pattern 1 will extinguish and that LED for BGM Pattern 2 LED will light green to indicate that the BGM Pattern 2 base pattern is in use.

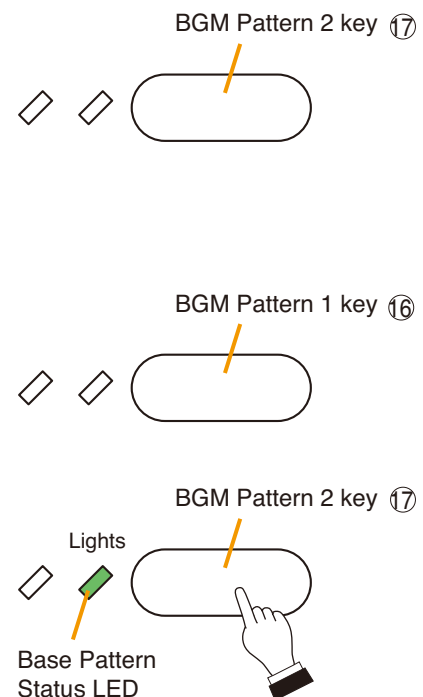

#### Notes

- When recalling base patterns using the control input, assign patterns to the control input using the same method used for the Remote Microphone function keys.
- Pressing the Base Pattern key engaged in a BGM broadcast (its Base Pattern Status LED is lighting) will stop the BGM broadcast.



[Example for BGM pattern recalled from the Remote Microphone]

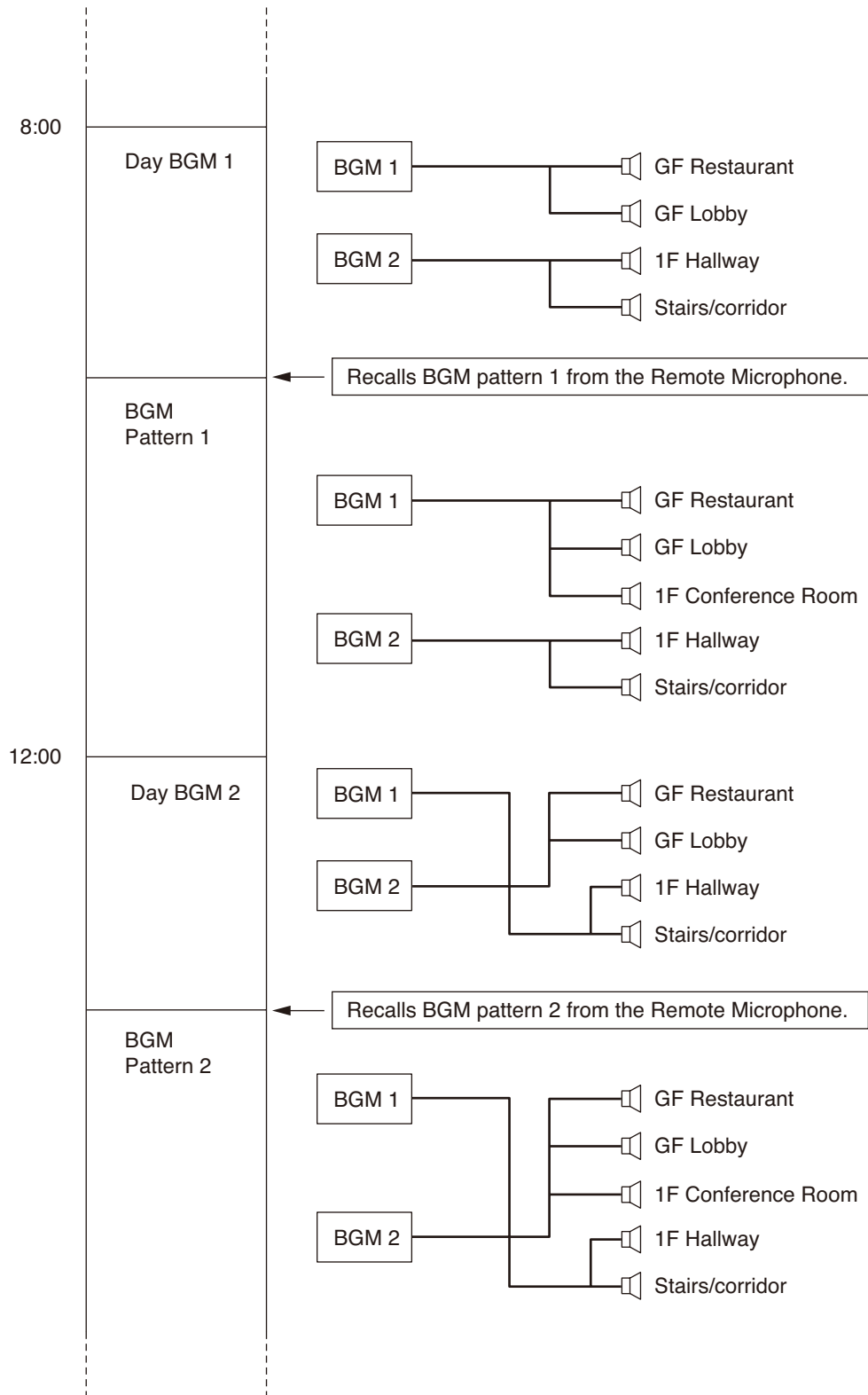

### 3.3. Changing the Input Sensitivity and Output Volume Level

By assigning predetermined volume patterns to the Remote Microphone's function keys, the initially set input sensitivity and output volume level can be changed.

#### Notes

- The input sensitivity can only be changed for sources (such as the Paging Microphone and BGM source) connected to the VX-200XI input module or 900 Series modules. Initial volume settings can be performed for the Remote Microphone and built-in EV and chime units. However, their initial volume levels cannot be changed during operation.
- The output volume level can only be changed for zones where BGM broadcasts are being made. Calls from the Remote Microphone or messages of the built-in EV unit are broadcast at the initially set volume level.
- The initial output volume level can be set using the PC software.

#### 3.3.1. Changing the input sensitivity and output volume level at the Remote Microphone

Both the input sensitivity and output volume level can be changed between -21 dB and 0 dB in 3 dB step. They change by 3 dB each time the corresponding Remote microphone's key is pressed. When the input sensitivity or output volume level reaches -21 dB or 0 dB, further key operation to exceed the limit is ignored.

**[Example 1]**

Adjusting the BGM Input Level to Compensate for Changes in Music Dynamics.

**Step 1.** To increase the sound volume when the music changes from a more dynamic selection to a quieter tune, press the BGM 1 Volume Up key ⑱.

The input level increases by 3 dB each time the key is pressed.

The Volume Up LED lights green to indicate that the input level is higher than the initially set value.

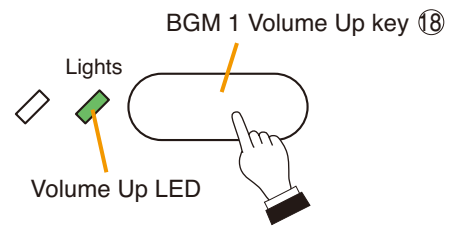

**Step 2.** To decrease the sound volume when the music seems too loud, press the BGM 1 Volume Down key ⑲.

The input level decreases by 3 dB each time the key is pressed.

The Volume Up LED extinguishes when the input level returns to the initially set value.

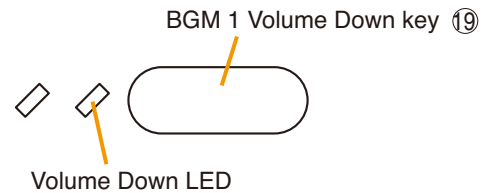

The Volume Down LED lights green when the input level drops below the initial setting.

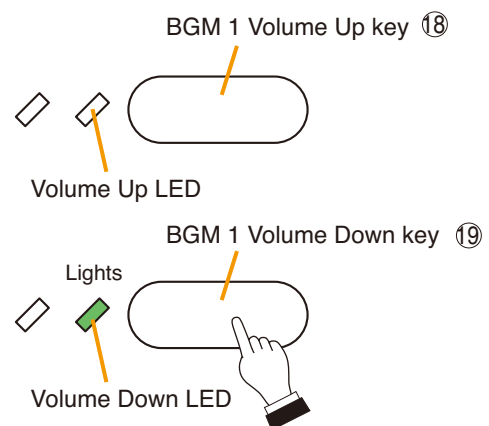
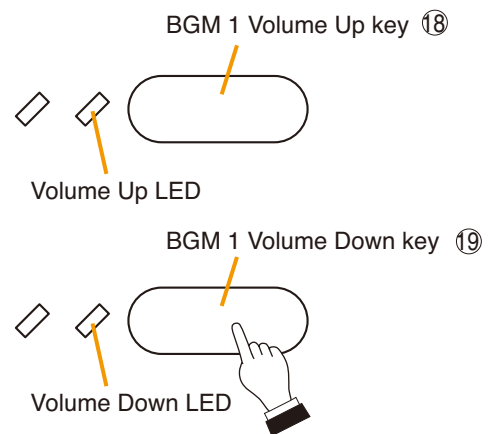

**[Example 2]**

Adjusting BGM Output Levels to Compensate for Changes in Lobby Congestion

**Step 1.** If the lobby becomes unclouded and quiet, the BGM output level can be reduced by pressing the Lobby Volume Down key ⑳.

The output level decreases by 3 dB each time the key is pressed.

The Volume Down LED lights green when the output level drops below the initial value.

As in the case of Example 1, when the output level returns to the initially set level, the Volume Down LED extinguishes to indicate that the output level has dropped below the initial value. When the output level increases above the initial value, the Volume Up LED lights green.

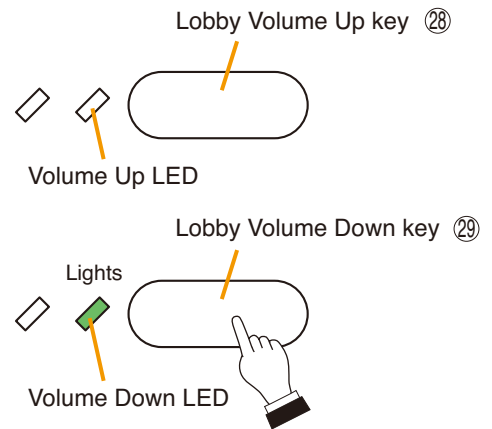

**Notes**

- When calls are made to the lobby from the Remote Microphone, they are broadcast at the initially set volume level.
- When the input sensitivity or output volume level reaches -21 dB or 0 dB, further key operation to exceed the limit is ignored.

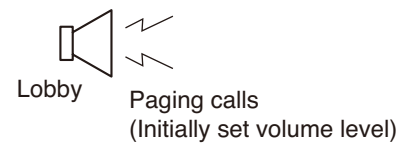

### 3.3.2. Changing the input sensitivity and output volume by way of the control input or internal timer

Both the input sensitivity and output volume level can be changed between -21 dB and 0 dB. Their increment or decrement level can be selected from 3, 6, 9, 12, 15, 18, or 21 dB.

**Note**

Both changes of the input sensitivity and output volume level are relative to the initially set levels. The changed levels will not exceed the range from -21 dB to 0 dB.

**[Change by means of the control inputs]**

The input sensitivity or output volume level is continuously changed while the corresponding control input is activated.

**[Change by means of the internal timer]**

The input sensitivity or output volume level is continuously changed during the duration from the start time to the end time set by the internal timer.

**[Setting example]**

No.	Start	End	Event	Name
1	09:00		Base Pattern Change	Day BGM 1
2	12:00		Base Pattern Change	Day BGM 2
3	18:00		Base Pattern Change	Night BGM
4	22:00		Base Pattern End	
5	11:00	20:00	Volume Up	BGM 1
6	00:00	00:15	None	
7	00:00	00:15	None	
8	00:00	00:15	None	
9	00:00	00:15	None	
10	00:00	00:15	None	
11	00:00	00:15	None	
12	00:00	00:15	None	
13	00:00	00:15	None	
14	00:00	00:15	None	
15	00:00	00:15	None	
16	00:00	00:15	None	...

From 10:00 to 15:00, BGM is broadcast in the lobby at the volume higher than the initially set level. The output level increment can be set for 3, 6, 9, 12, 15, 18, and 21 dB on a PC.

### 3.4. Interrupt Broadcasts

Interrupt broadcasts can be activated from the control input or internal timer. Preprogrammed interrupt broadcast patterns are recalled to make broadcasts during activation.

#### Notes

- To make the Interrupt broadcast to a currently broadcast zone, the interrupt broadcast source should be higher in priority than the current broadcast or should be assigned the LIFO priority if both broadcasts are the same in priority level. For the priority settings, refer to [p. 7-30](#).
- If the assigned input sources are the same, broadcasts are made to every output zone set in all recalled patterns.
- If the assigned input sources are different, but the recalled pattern output zones are duplicated, the input source assigned the highest priority is broadcast to all duplicated zones, while other recalled sources are broadcast to the corresponding output zones that are not among the duplicated zones.

#### [Activation by means of the control inputs]

The Interrupt broadcast having its preset pattern overrides the current broadcast while the corresponding control input is activated.

#### [Change by means of the internal timer]

The Interrupt broadcast having its preset pattern overrides the current broadcast during the duration from the start time to the end time set by the internal timer.

### 3.5. EV Message Broadcasts

#### 3.5.1. Making EV broadcasts from the Remote Microphone

EV messages assigned to the Remote Microphone's function keys can be broadcast to the selected zones.

**[Example]**

Broadcasting the general-purpose EV message 1 to the lobby.

**Step 1.** Press the Lobby Zone Select key ① to select the desired broadcast zone.

The Select LED will light green.

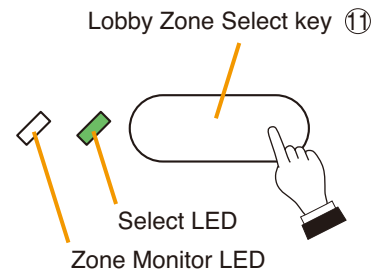

**Step 2.** Press the EV Message 1 key ② .

The EV Broadcast LED will light green, and the selected message will be broadcast to the lobby.

**Tip**

To stop the message halfway through broadcast, press the EV Message 1 key ② again.

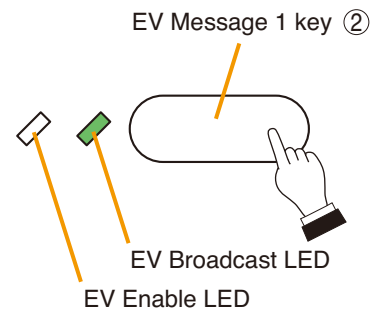

The Zone Monitor LED will flash green to indicate that the EV message is being broadcast to the selected zone.

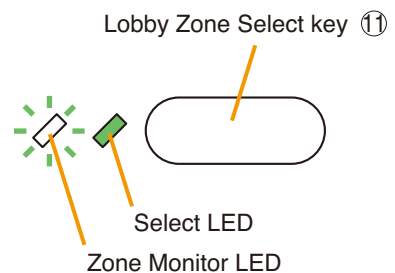

### 3.5.2. Making EV broadcasts by way of the control input or internal timer

By activating the EV broadcast patterns assigned to the control input or internal timer, the corresponding EV messages can be broadcast.

#### Notes

- To make the EV broadcast to a currently broadcast zone, the EV message priority should be higher than the current broadcast or should be assigned the LIFO priority if both broadcasts are the same in priority level. For the priority settings, refer to [p. 7-30](#).
- If the assigned EV messages are the same, the message is broadcast to every zone set in all recalled patterns.
- If the assigned EV messages are different, but the recalled pattern output zones are duplicated, the EV message assigned the highest priority is broadcast to all duplicated zones, while other recalled messages are broadcast to the corresponding output zones that are not among the duplicated zones.

#### [Activation by means of the control inputs]

The EV broadcast having its preset pattern overrides the current broadcast while the corresponding control input is activated.

#### [Change by means of the internal timer]

The EV broadcast having its preset pattern overrides the current broadcast during the duration from the start time to the end time set by the internal timer.



## 4. AUDIO MONITORING

Selecting a zone to monitor permits the currently broadcast zone to be monitored.

Broadcast can be monitored through the Remote Microphone's internal speaker when activated from a Remote Microphone or through the VX-2000's rear-mounted MONITOR OUT terminal when activated by a VX-2000's or VX-200SI's control input signal.

The Audio Monitoring function to zones can be set by the PC setting software.

### Note

The Audio monitoring automatically terminates in 10 seconds.

### 4.1. Monitoring by means of a Remote Microphone

Press the Zone 1 Monitor key.

The corresponding Monitor LED will light green.

The current broadcast to the Zone 1 can be monitored for 10 seconds through the Remote Microphone's internal speaker.

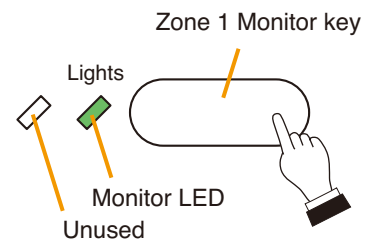

Remote Microphone  
RM-200X

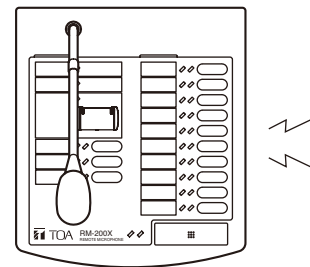

### 4.2. Monitoring by means of the VX-2000's MONITOR OUT Terminal

Activating the audio monitoring function using a control signal permits the VX-2000's rear-mounted MONITOR OUT terminal to output the selected zone broadcast signals for 10 seconds.

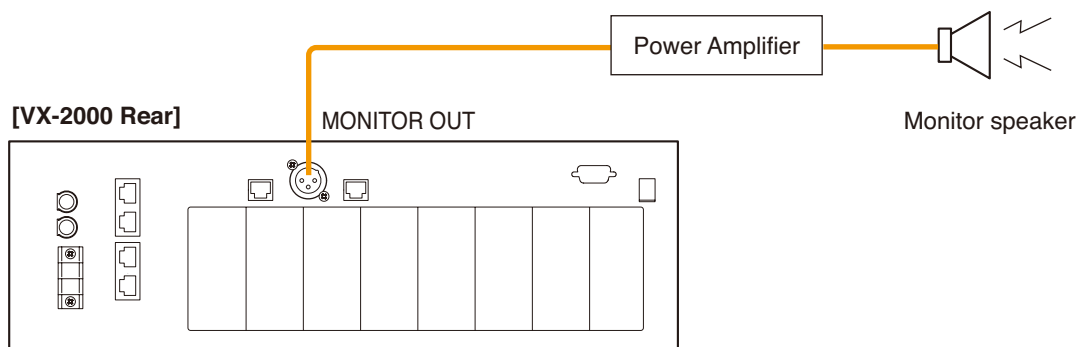

## 5. FAILURE OUTPUT DETECTION

Here, the settings of the Remote Microphone with the "Failure Output" indication set are used as an example to explain system operation when a failure occurs.

### 5.1. Failure Output Indication

#### [GF Security Room Remote Microphone Settings]

A set of the RM-200X and 3 RM-210 units is installed in the GF Security Room.

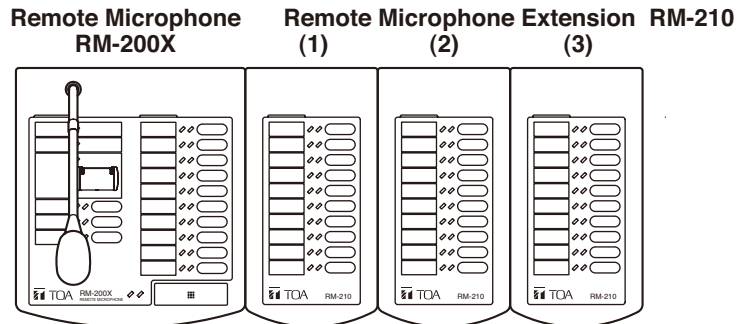

#### [Function Key Setting Example]

Patterns that indicate individual failures and total system failure are assigned to the Remote Microphone.

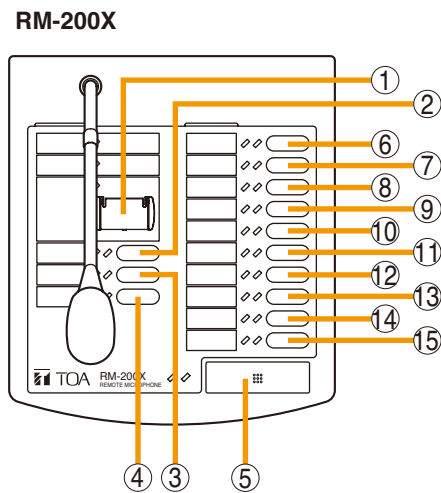

Key	Setting	Function
①	Emergency Activation	Activates the emergency broadcast mode.
②	Emergency Reset	Restores to general-purpose broadcast mode.
③	Emergency Reset (error)	Restores to general-purpose broadcast mode after broadcasting the false alarm EV message.
④	All	Pre-selects the entire area.
⑤	Talk with 2 Tone Chime	Makes microphone announcements.
⑥	Back Room	Pre-selects individual zones.
⑦	GF	
⑧	1F	
⑨	2F	
⑩	3F	Recalls individual EV messages.
⑪	EV Message 1	
⑫	EV Message 2	Indicates total system failure. (Assignment of all failure outputs)
⑬	Failure Confirmation	
⑭	Failure Output Reset	Resets failure indications.
⑮	None	No function assigned.

RM-210 (1)

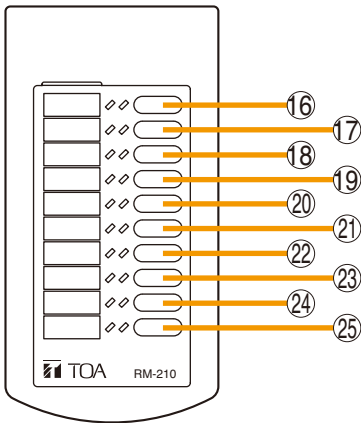

RM-210 (2)

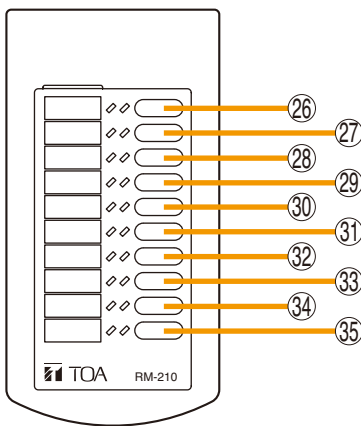

RM-210 (3)

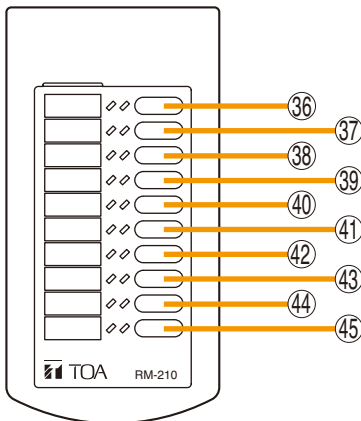

Key	Setting	Function
16	Back Room Speaker Open	Indicates individual speaker failure. (Open circuit)
17	GF Speaker Open	
18	1F Speaker Open	
19	2F Speaker Open	
20	3F Speaker Open	
21	RM200XF Failure	Indicates individual Remote Microphone failure.
22	RM200X-1 Failure	
23	RM200X-2 Failure	
24	VX Failure	Indicates VX-2000 failure.
25	EV Failure	Indicates EV-200 failure.
26	Back Room Speaker Short	Indicates individual speaker failure. (Short)
27	GF Speaker Short	
28	1F Speaker Short	
29	2F Speaker Short	
30	3F Speaker Short	Indicates individual VX-2000SF unit failure.
31	SF Failure	
32	DS-1 Failure	
33	DS-2 Failure	Indicates individual VX-2000DS or VX-3000DS unit failure.
34	Standby Amplifier Failure	Indicates individual standby amplifier unit failure.
35	None	No function assigned.
36	Back Room Amplifier Failure	Indicates individual power amplifier failure.
37	GF Amplifier Failure	
38	1F Amplifier Failure	
39	2F Amplifier Failure	
40	3F Amplifier Failure	No function assigned.
41	None	
42	None	
43	None	
44	None	
45	None	

**[Example]**

Assuming a Shorted Speaker Line on 3F has been detected:

**Step 1.** When a failure is detected, a buzzer sounds, and both left-side Failure LEDs located next to the 3F Speaker Short key ③⑩ and Failure Confirmation key ①③ flash orange.

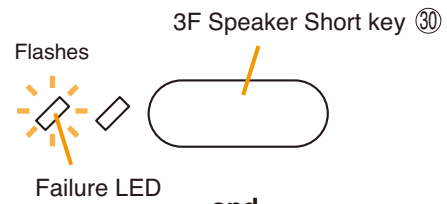

and

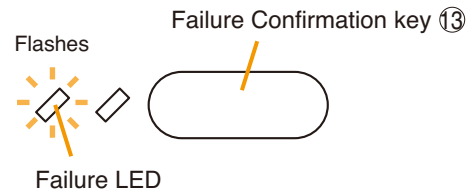

**Step 2.** Press either the Speaker Short key ③⑩ or the Failure Confirmation key ①③ to acknowledge the failure.

The buzzer stops and the failure LED changes from flashing orange to steady orange.

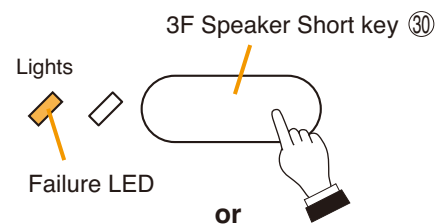

or

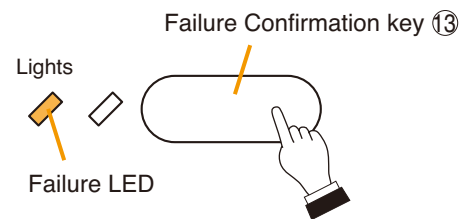

**Step 3.** Investigate and correct the problem.

Connect a PC to the VX-2000, investigate the cause of the failure by reading out the log, and correct the problem.

If necessary, check all connections using the PC software. For log readout and connection check, refer to p. 11-7.

**Tip**

For most failure indications, the failure LED automatically extinguishes when the cause has been corrected. For certain other failure indications, such as power amplifier failure or speaker shorts, the LED does not automatically extinguish. In such cases, Failure Output Reset needs to be performed.

**Step 4.** Press the Failure Output Reset key ①④.

All of the failure LEDs will be extinguished.

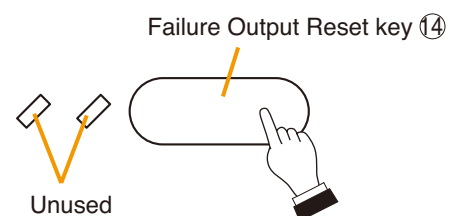

**Note**

Make sure that the system's power is switched OFF if there is a chance of bodily contact with the internal components or live parts of the equipment when investigating the cause of a failure. For procedures regarding switching off the system power, refer to the Instruction Manual attached to the VX-2000DS/3000DS.

## 5.2. Monitoring Log List

Possible causes of detected failures can be confirmed in the View Log window.  
For reading out the log file, refer to p. 11-7.

Table below lists failure logs, possible causes, and their solutions.

### [RM-200XF]

Log		Possible Cause	Solution
Detail code	Additional Information		
RM/FM Monitor	RM* Microphone Occurrence	Microphone element broken or coiled cord disconnected	Consult TOA dealer
	RM* Microphone Switch Occurrence	Microphone key or Emergency key broken	Consult TOA dealer
	RM* Low Power Supply Voltage Occurrence	Power supply to RM dropped	Supply power directly from VX-2000DS /3000DS.
			Use the connection cable with lower loss.
	RM* Low Power Supply	RM to VX-200XR LINK connectors misconnected	Check for the connector to be connected to and the connection cable.
	RM* Communication Occurrence	RM to VX-200XR LINK connectors misconnected	Check for the connector to be connected to and the connection cable.
RM* Fault No. of RM-210 Occurrence	Actual No. of RM-210s and PC-set No. unmatched	Match both Nos. by changing either. (If the PC setting is changed, download it.)	

\* A component ID number is displayed here.

### [RM-200X]

Log		Possible Cause	Solution
Detail code	Additional Information		
RM/FM Monitor	RM* Microphone Occurrence	Microphone element broken	Consult TOA dealer
	RM* Low Power Supply Voltage Occurrence	Power supply to RM dropped	Supply power directly from VX-2000DS /3000DS or an AC adapter.
			Use the connection cable with lower loss.
	RM* Line Occurrence	RM to VX-200XR LINK connectors misconnected	Check for the connector to be connected to and the connection cable.
	RM* Communication Occurrence	RM to VX-200XR LINK connectors misconnected	Check for the connector to be connected to and the connection cable.
RM* Fault No. of RM-210 Occurrence	Actual No. of RM-210s and PC-set No. unmatched	Match both Nos. by changing either. (If the PC setting is changed, download it.)	

\* A component ID number is displayed here.

### [EV-200]

Log		Possible Cause	Solution
Detail code	Additional Information		
EV Monitor	EV* Fault Occurrence	EV-200 failed	Consult TOA dealer
		Unusable CF card installed	Install a correct card.
		No CF card installed.	Install a card.
	EV* 1 kHz Failure Occurrence	No CF card installed.	Install a card.
		EV-200's DIP switch setting not performed	Check for the EV-200's DIP switch setting.

\* A component Unit number is displayed here.

**[VX-2000]**

Log		Possible Cause	Solution
Detail code	Additional Information		
VX Monitor	Bus1 Occurrence Bus2 Occurrence Bus3 Occurrence Bus4 Occurrence	No signal output on Audio Buses 1-4 due to VX-2000 failure	Consult TOA dealer

**[VX-2000SF]**

Log		Possible Cause	Solution
Detail code	Additional Information		
SF Monitor	SF*VX-SF Bus1 Occurrence SF*VX-SF Bus2 Occurrence SF*VX-SF Bus3 Occurrence SF*VX-SF Bus4 Occurrence	VX-2000 to VX-2000SF or VX-2000SF to VX-2000SF AUDIO LINK connectors misconnected	Check for the connector to be connected to and the connection cable.
	SF*Bus Selector1 Occurrence SF*Bus Selector2 Occurrence SF*Bus Selector3 Occurrence SF*Bus Selector4 Occurrence SF*Bus Selector5 Occurrence SF*Bus Selector6 Occurrence SF*Bus Selector7 Occurrence SF*Bus Selector8 Occurrence SF*Bus Selector9 Occurrence SF*Bus Selector10 Occurrence	Signals on Audio Buses 1-4 undetected due to VX-2000SF or VX-2000SZ/SP/SE failure	Consult TOA dealer
	SF* Communication Occurrence	VX-2000 to VX-2000SF or VX-2000SF to VX-2000SF DATA LINK connectors misconnected	Check for the connector to be connected to and the connection cable.

\* A component ID number is displayed here.

**[VP-2000 series amplifiers, VP-3000 series amplifiers]**

Log		Possible Cause	Solution
Detail code	Additional Information		
Amplifier Monitor	AMP* 20 kHz(NF) Occurrence	Amplifier failed	Consult TOA dealer
		VP-200VX to VP-200SZ or VP-200VX to VX-200SP PA LINK connectors misconnected	Check for the connector to be connected to and the connection cable.
	AMP* DC Fuse Occurrence	Amplifier's DC fuse blown	Replace the Blade fuse of 7.5 A (VP-2064), 15 A (VP-2122), 25 A (VP-2241), 35 A (VP-2421) or 20 A (VP-3154/3304/3504). Refer to <a href="#">p. 8-43</a> .
	AMP* Amplifier Connection Occurrence	Amplifier's PA OUT to VX-200SZ's PA IN connectors misconnected	Check for the connector to be connected to and the connection cable.

\* A component Unit number is displayed here.

**[Standby Amplifier]**

Log		Possible Cause	Solution
Detail code	Additional Information		
Amplifier Monitor	AMP* 20 kHz(NF) Occurrence	Standby amplifier failed	Consult TOA dealer
Standby Amplifier	AMP* STBY*	Amplifier failure detected, operation being switched to standby amplifier	—
Standby Bus Check	SF* Slot1 Occurrence SF* Slot2 Occurrence SF* Slot3 Occurrence SF* Slot4 Occurrence SF* Slot5 Occurrence SF* Slot6 Occurrence SF* Slot7 Occurrence SF* Slot8 Occurrence SF* Slot9 Occurrence SF* Slot10 Occurrence	VX-2000SF to standby amplifier misconnected	Check for the connector to be connected to and the connection cable.
		Standby amplifier's PA OUT to VX-200SP/SZ's STANDBY PA BUS connectors misconnected	

\* A component Unit or ID number is displayed here.

**[Speaker]**

Log		Possible Cause	Solution
Detail code	Additional Information		
SP Monitor	SP* Open Circuit Occurrence	Speaker line disconnected	Check for the speaker, its connection, and cable.
		Speaker line shorted (VX-200SP, far end)	
	SP* Short Circuit Occurrence	Speaker line shorted	
	SP* Ground Fault Occurrence	Speaker line grounded	

\* A component Zone number is displayed here.

**[VX-2000DS, VX-3000DS]**

Log		Possible Cause	Solution	
Detail code	Additional Information			
DS Monitor	DS* no DS Occurrence	VX-2000DS or VX-3000DS power failed	Restore AC power to VX-2000DS or VX-3000DS.	
		AC fuse blown	Consult TOA dealer	
		VX-2000SF to VX-2000DS or VX-3000DS DS-SF LINK connectors misconnected	Check for the connector to be connected to and the connection cable.	
		No AC power supplied to VX-200PS (ER/UK version)	Supply AC power to VX-200PS.	
		VX-200PS misconnected (ER/UK version)	Check for the connector to be connected to and the connection cable.	
		VX-200PS failed (ER/UK version)	Consult TOA dealer	
		DS* Power Failure Occurrence	No AC power supplied to VX-200PS	Supply AC power to VX-200PS.
			VX-200PS misconnected	Check for the connector to be connected to and the connection cable.
			VX-200PS failed	Consult TOA dealer
		DS* Charging Circuit Occurrence	Battery charging circuit failed	Consult TOA dealer
	Charging circuit fuse blown		Consult TOA dealer	
	Battery misconnected		Check for the connector to be connected to and the connection cable.	
	DS* Battery Failure Occurrence	Battery voltage dropped	Replace the battery.	

\* A component Unit number is displayed here.

# ***Chapter 6***

---

## ***FLOWCHART FROM SYSTEM SETUP TO OPERATION***



# 1. PROCEDURE TO SYSTEM OPERATION

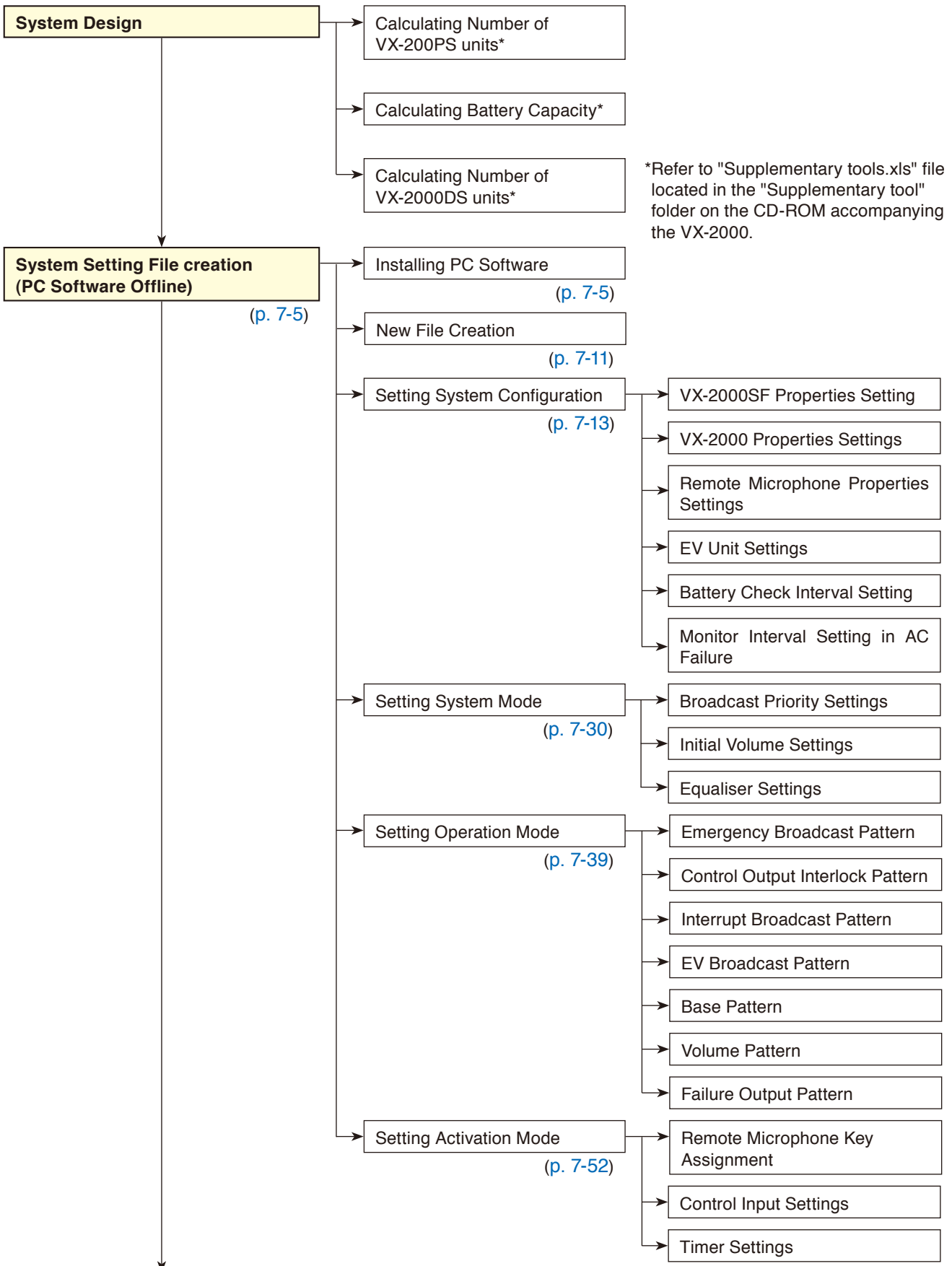

To the next page

Continued from the previous page

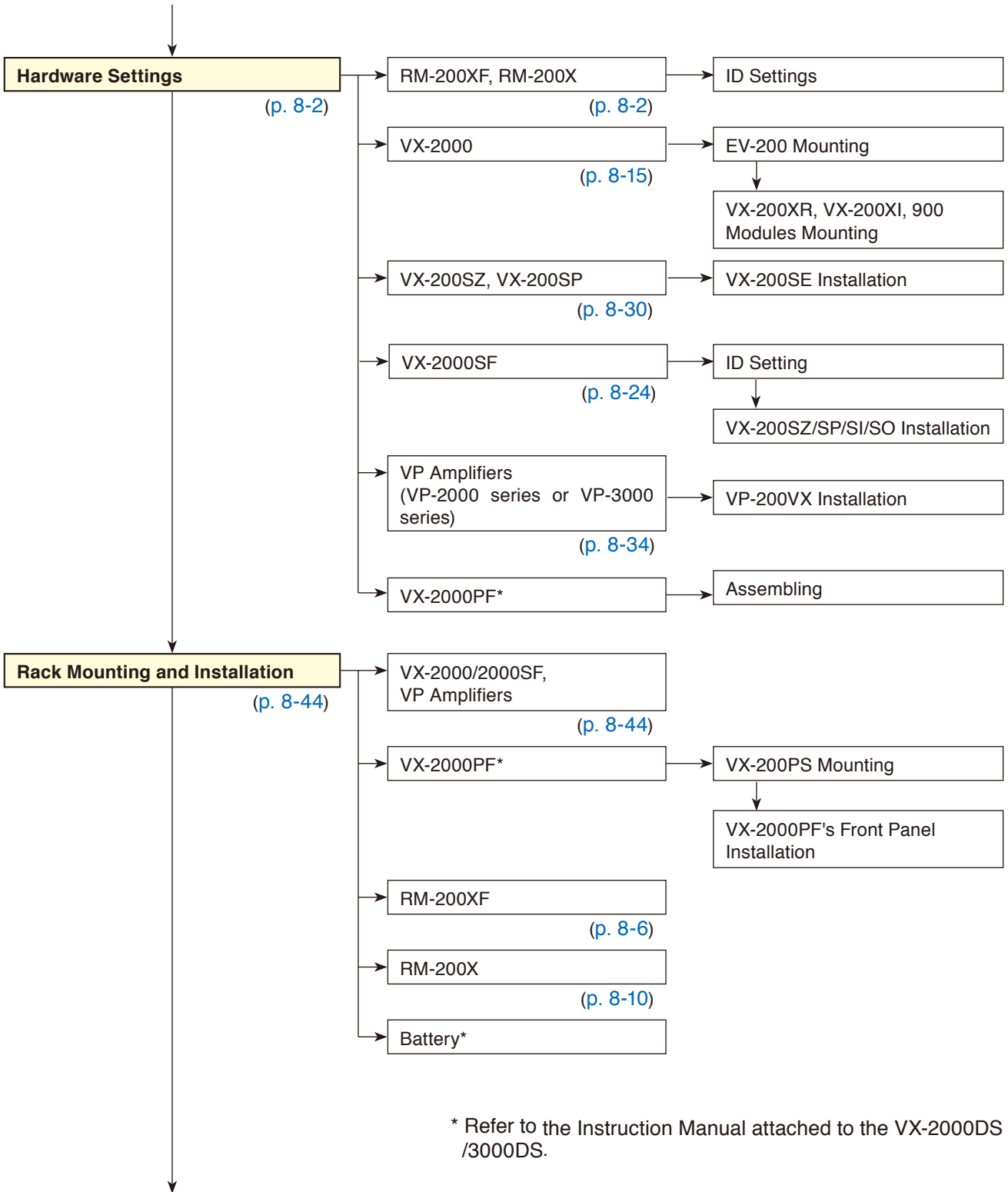

\* Refer to the Instruction Manual attached to the VX-2000DS /3000DS.

To the next page

Continued from the previous page

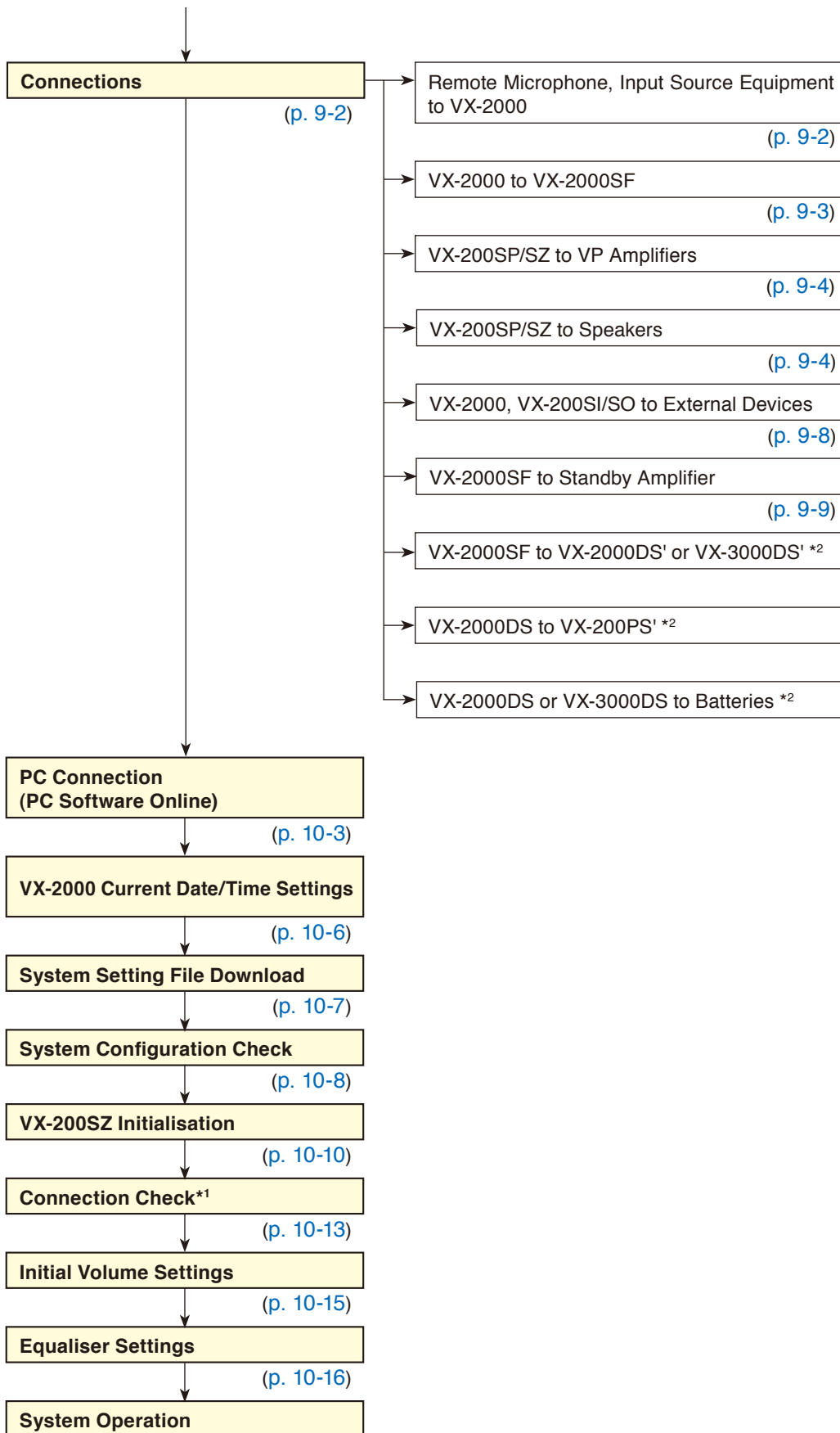

\*1 This function applies to the VX-2000 Setting Software Version 2.0 or later.

\*2 Refer to the Instruction Manual attached to the VX-2000DS/3000DS.

# ***Chapter 7***

---

## ***PC SOFTWARE OFFLINE SETTINGS***

# 1. SETUP PROCEDURE (from installation to settings)

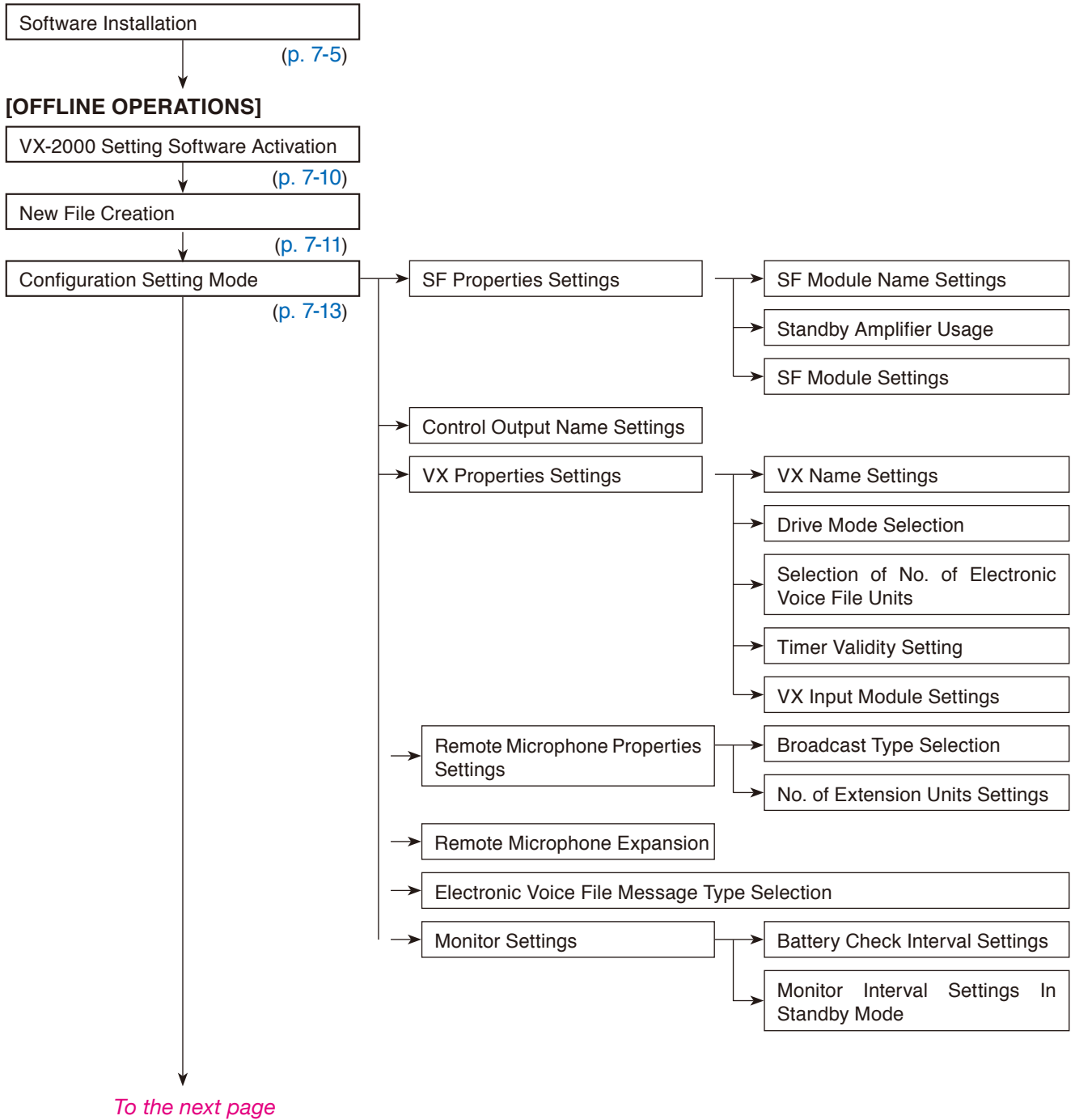

Continued from the previous page

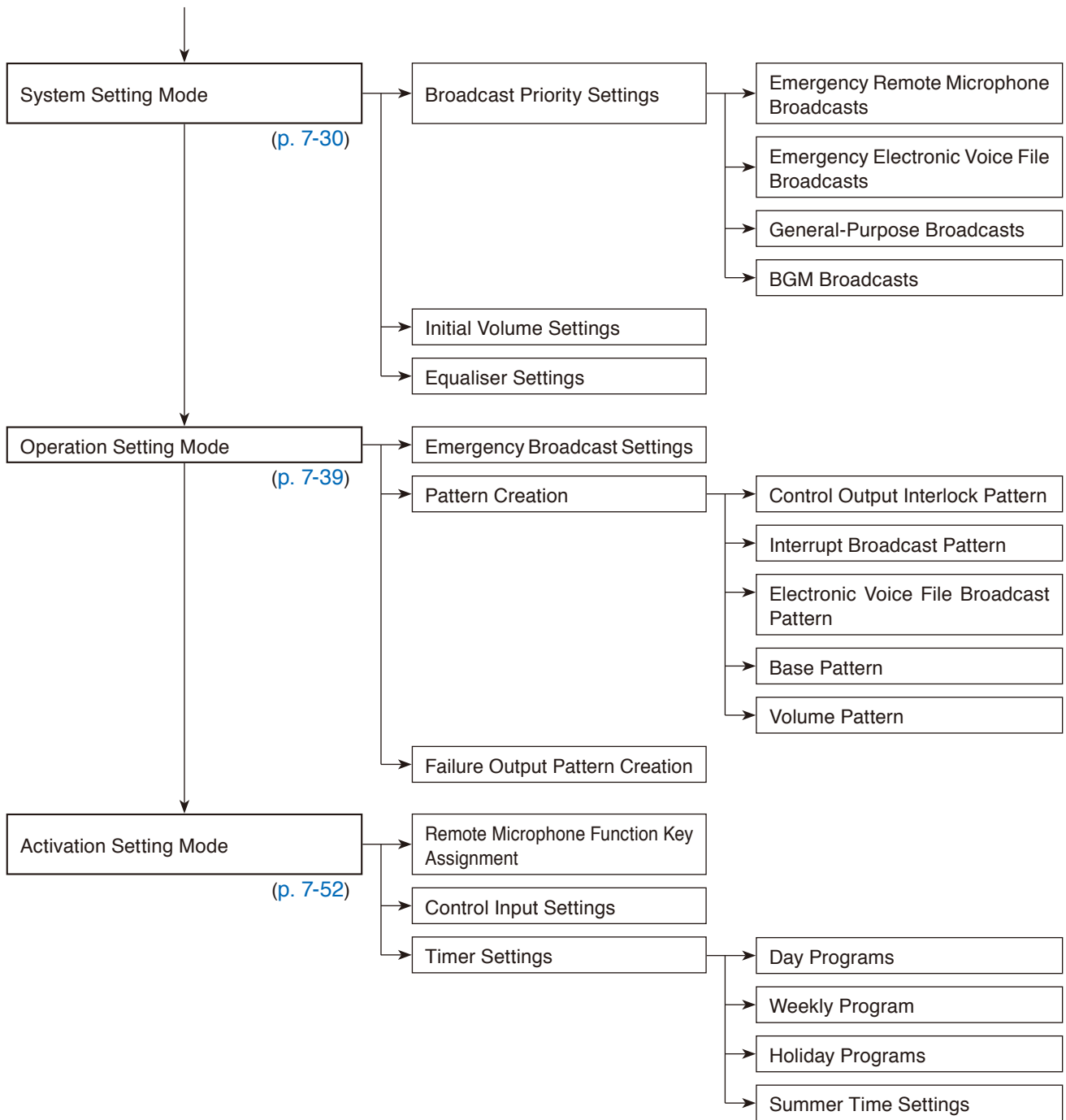

## 2. HARDWARE REQUIREMENT

The VX-2000 setting software is designed to be exclusively used with the VX-2000 System. The Microsoft Windows-based VX-2000 software can be used with most Windows-compatible personal computers.

Hardware requirements are given below.

OS	Windows 2000/XP/Vista/7
CPU Operating Speed	233 MHz Pentium II or faster
Memory Capacity	64 MB RAM or more
Available Hard Disk Space	20 MB or more
Available Serial Port	RS-232C
Monitor Size	800 x 600 high colour (16 bit) or more
Built-in Media Drive	CD-ROM drive

### Notes

- Windows and Windows Vista are registered trademarks of Microsoft Corporation in the United States and other countries.
- Pentium is a trademark of Intel Corporation in the U.S. and/or other countries.

### 3. SOFTWARE INSTALLATION

Install the VX-2000 software following the procedure below.  
Terminate all applications before installation.

**Step 1.** Insert the VX-2000 setting software CD-ROM into the PC's CD-ROM drive.

**Step 2.** Double-click the file "VX2000.msi" in the setting software folder.  
The setup wizard will then be activated.



**Step 3.** Click on the [Next] button.

**Step 4.** Set the directory the software is installed in.

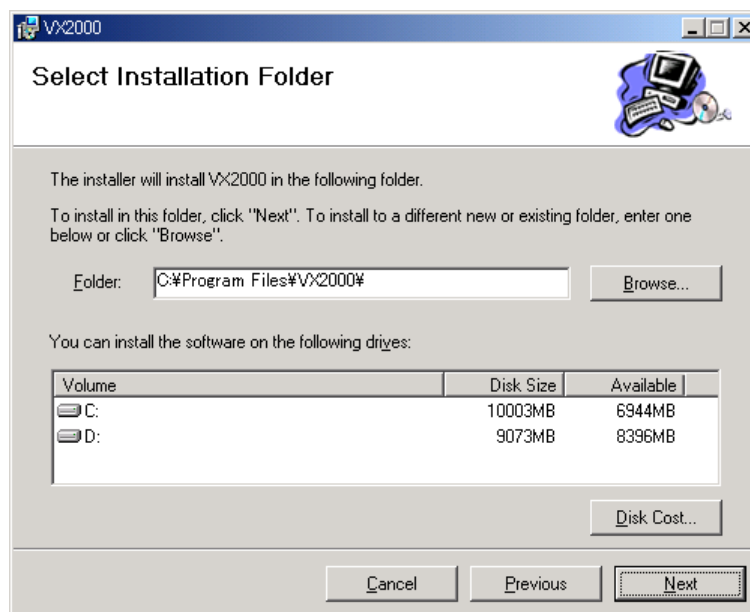

*Continued on next page*



**Step 5.** Click on the [Next] button.

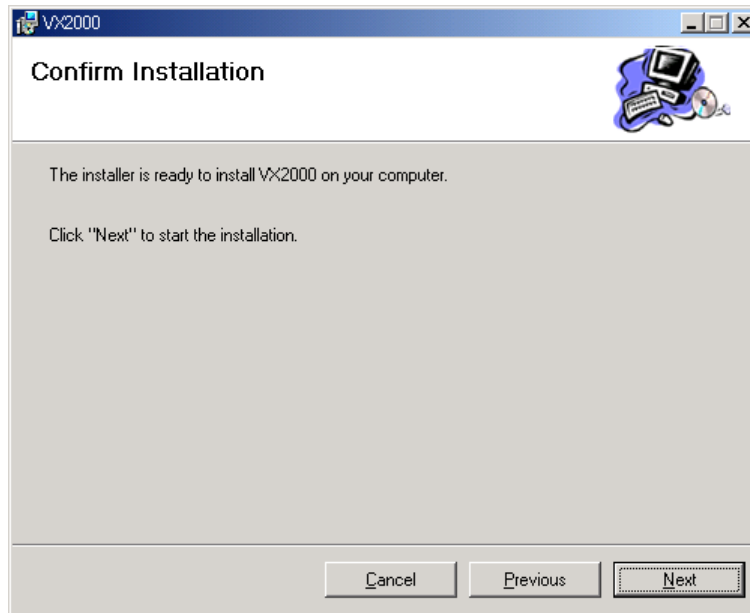

**Step 6.** Click on the [Next] button.  
Installation will be started.

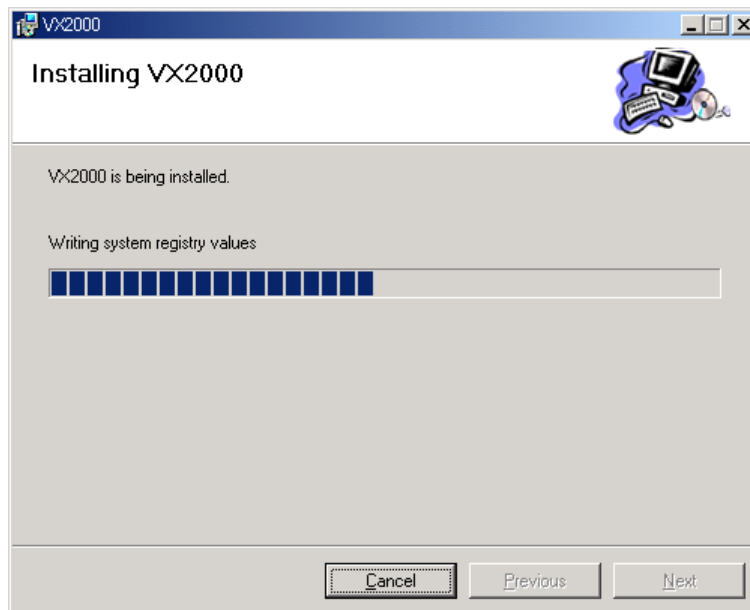

*Continued on next page*

The screen below will be displayed after setup completion.

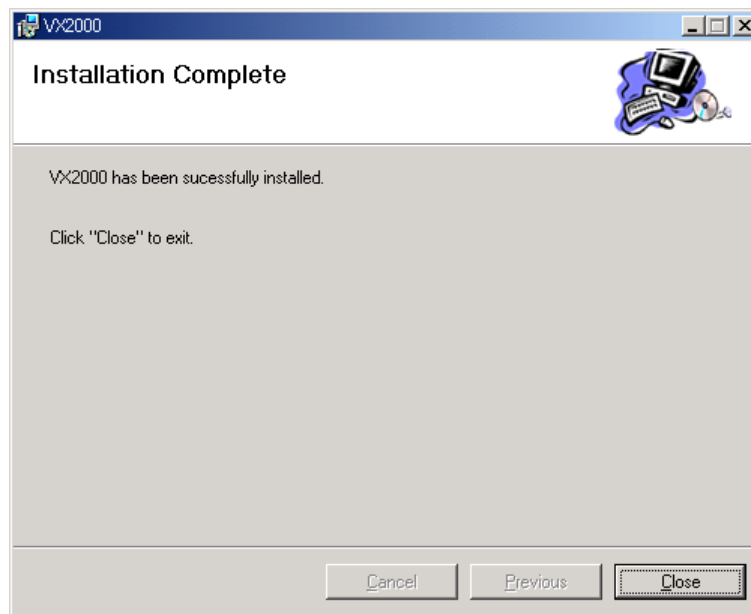

**Step 7.** Click on the [Close] button to close the screen.

## 4. SCREEN AND MENU DESCRIPTIONS

### 4.1. Screen

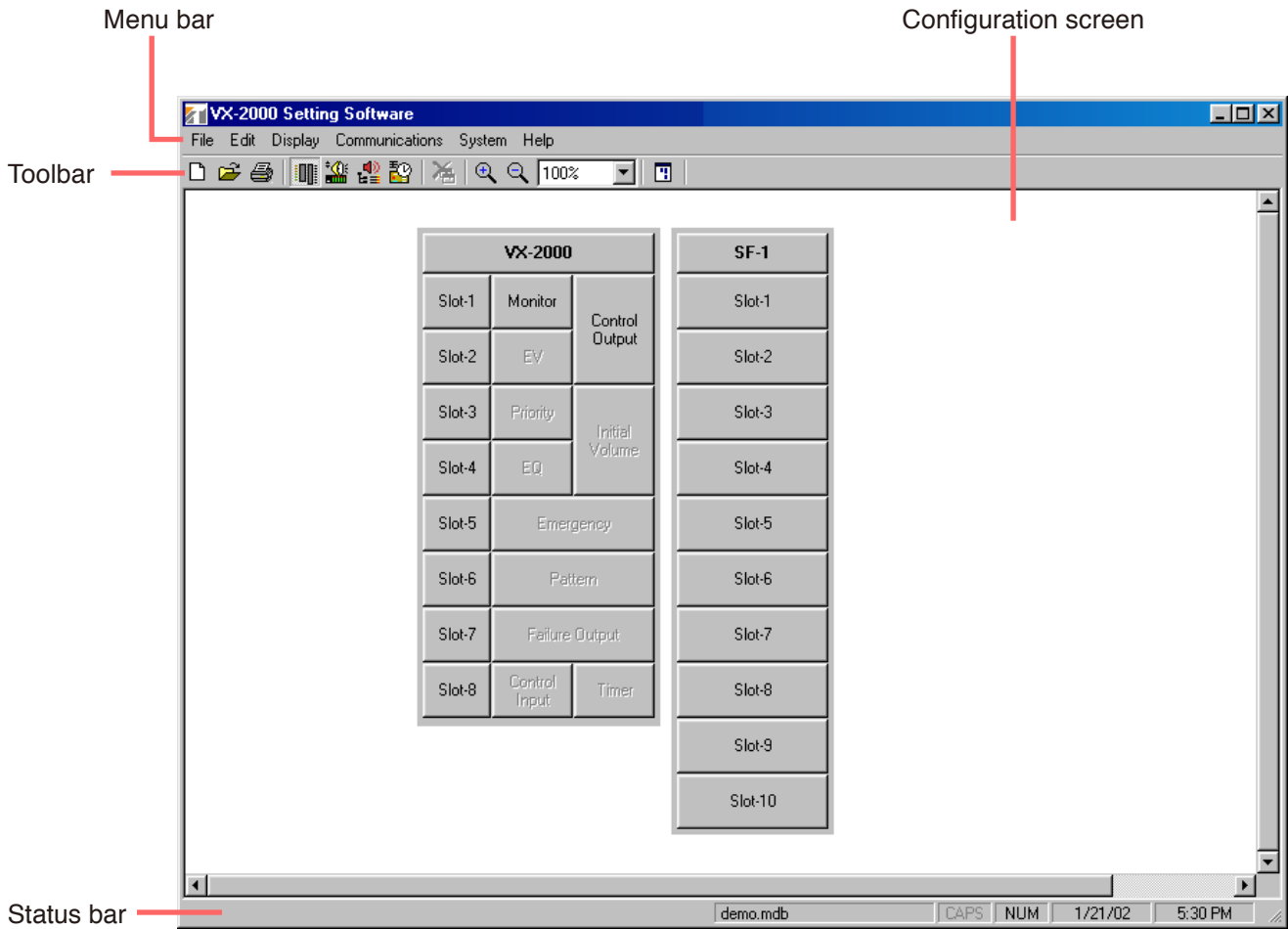

## 4.2. Menu

### • File

New	Creates a new system setting file.
Open	Opens an existing system setting file.
Properties	Changes system information.
Print	Used to select and print the setting contents of the system setting file.
Exit	Exits the VX-2000 setting software.

### • Edit

Configurations Setting Mode	Sets the equipment configuration.
System Setting Mode	Sets broadcasting priorities and initial volume.
Operation Setting Mode	Sets the emergency broadcast pattern, individual broadcast patterns, and failure output patterns to be monitored.
Activation Setting Mode	Sets the purpose of use of the control input.
RM Properties Setting End	Closes all RM (Remote Microphone) properties setting windows.

### • Display

Zoom	Zooms the screen. (150%, 125%, 100%, 75%, 50%)
View	Provides an overview window to be used as an on-screen navigator with the entire area map.
Toolbar	Enables or disables the toolbar display.
Status Bar	Enables or disables the status bar display.

### • Communications\*<sup>1</sup>

Download [PC → VX]	Loads the system setting file created by a PC into the VX-2000.
Upload [PC ← VX]* <sup>2</sup>	Reads the VX-2000 system setting file to a PC.

### • System\*<sup>1</sup>

General Settings	Performs date, time, and communication port settings.
Initial Impedance Settings	Initialises the output module VX-200SZ.
Configuration Check	Checks that the system setting file matches the actual equipment configuration.
Connection Check* <sup>2</sup>	Checks that equipment is correctly connected.
Monitor Operation Check* <sup>2</sup>	Checks the monitor function for correct operation.
Log	Reads the VX-2000's log file into a PC and displays it.

### • Help\*<sup>1</sup>

Version	Indicates the version numbers of the VX-2000 setting software and VX-2000 firmware.
---------	---

\*<sup>1</sup> On-line menu items. For functions and methods to use, refer to [Chapters 10](#) and [11](#).

\*<sup>2</sup> These functions apply to the VX-2000 Setting Software Version 2.0 or later.

## 5. VX-2000 SETTING SOFTWARE ACTIVATION

Select [VX-2000 → VX-2000 setting software] from the Windows start menu.  
The VX-2000 setting software will be activated.

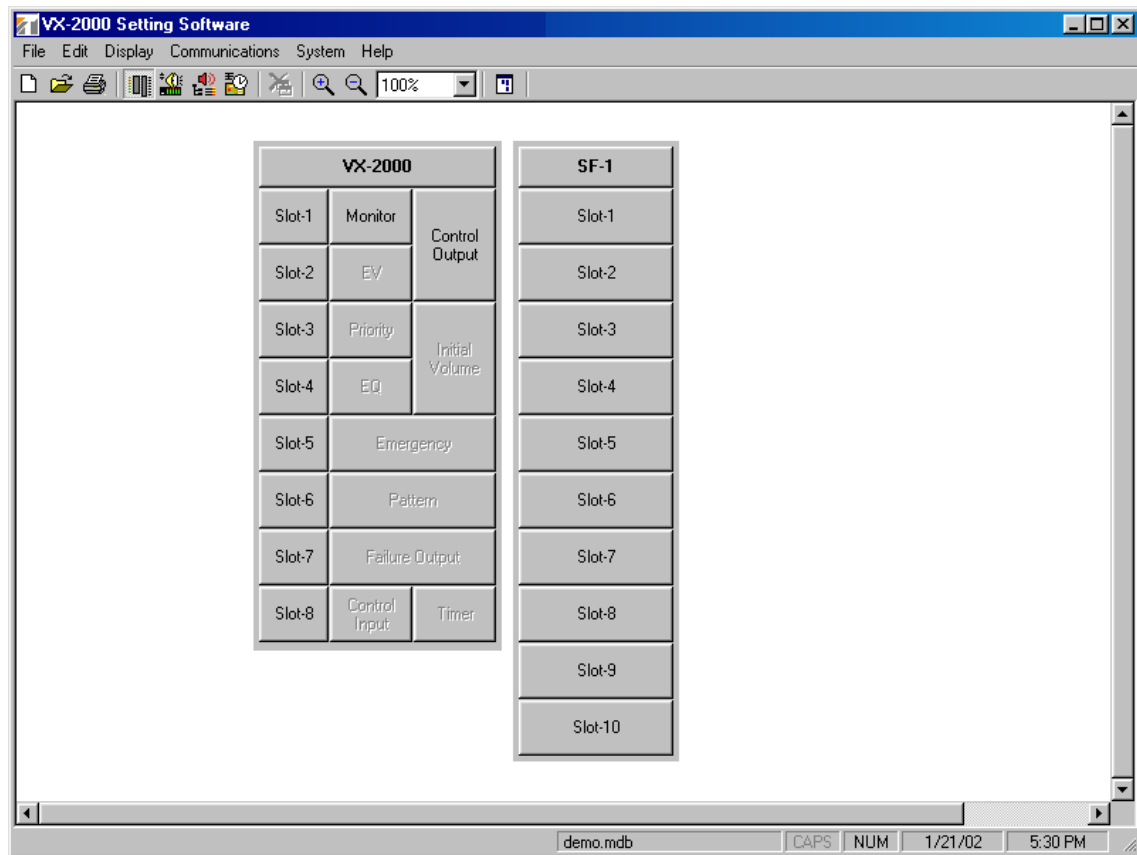

## 6. NEW FILE CREATION

Create a new system setting file according to the procedure below.

The system setting file is a file to be set for the users' operation of the VX-2000 system, and includes the following items: VX-2000 system configuration settings, priority settings, broadcast and control pattern creation, and function assignment to activation items (a remote microphone, control inputs, and internal timer).

**Step 1.** Select [File → New] from the menu or click on  toolbar button.

The [File Name] window will open.

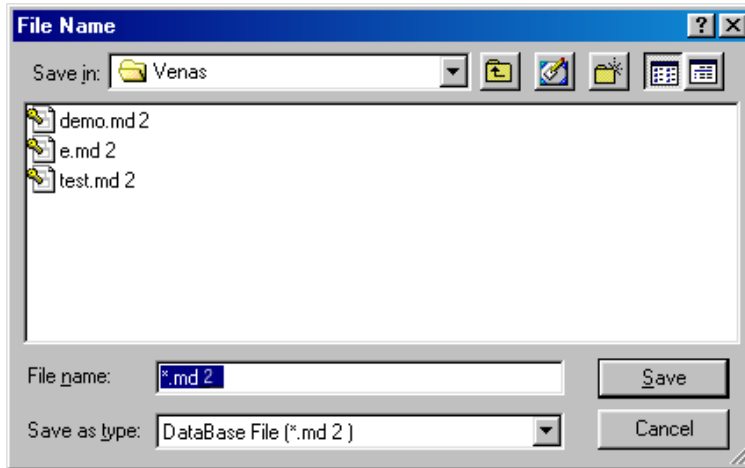

The system setting file is suffixed with an extension "mb2".

**Note**

The file extension is "mdb" for the VX-2000 Setting Software Version 2.0 or earlier.

**Step 2.** Enter a filename and click on the [Save] button.

The [System Information] window will open.

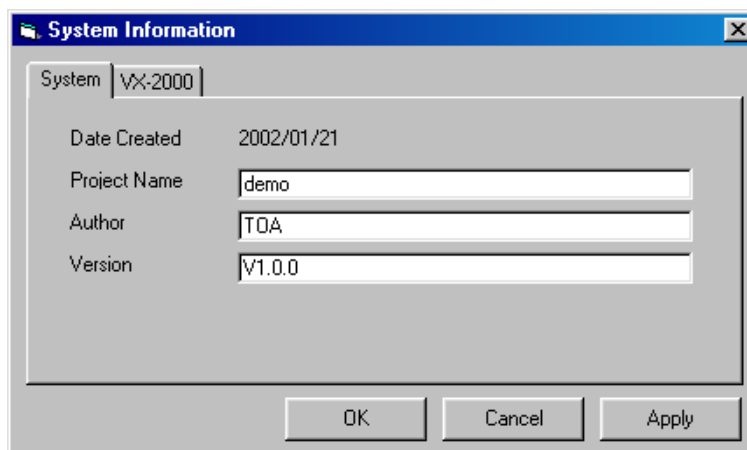

**Step 3.** Enter a project name, the name of Author, and Version.

**Note**

The version in the System Information window is not the PC setting software version. Enter the version here to manage your system setting file.

*Continued on next page*

**Step 4.** Click on the VX-2000 tab. Enter the VX-2000's name if necessary and select the number of connected VX-2000SF units.

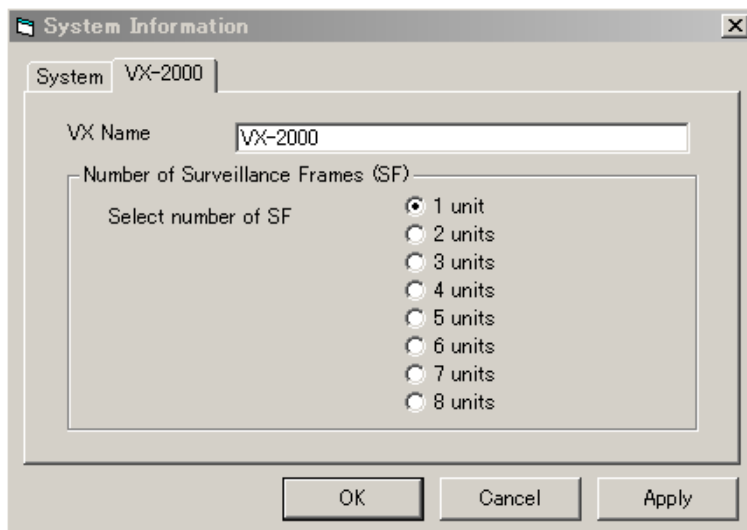

**Step 5.** Click on the [Apply] button to save the settings and click on the [OK] button. The [System Information] window will close, and the following configuration screen will be displayed, advancing the system to the configuration setting mode. Refer to the next page for setting procedures.

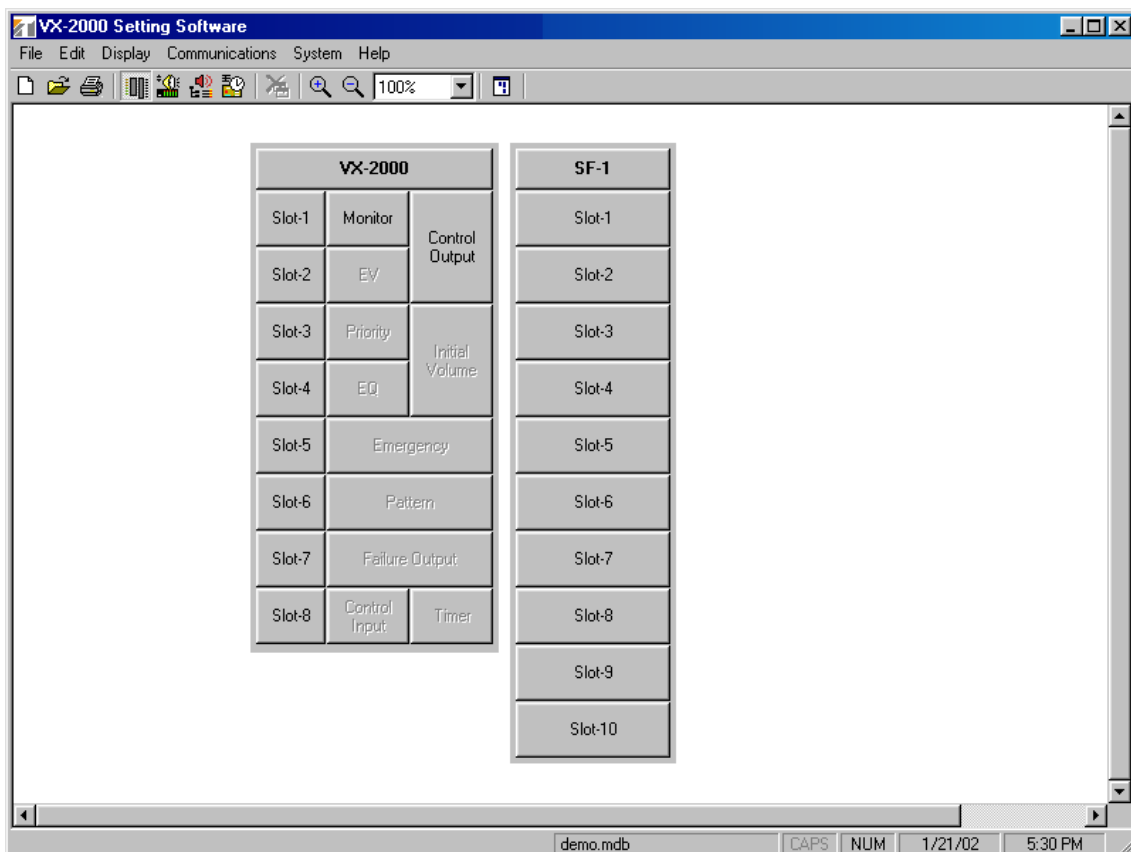

## 7. CONFIGURATION SETTING MODE

Select [Edit → Configuration Setting Mode] from the menu.

Instead of this, clicking on the  toolbar button also puts the system in the configuration setting mode.

Here, set the equipment to be used in the system, such as the SF module, VX module, and Remote Microphone.

### 7.1. SF Module Properties Setting

Set the name of the VX-2000SF unit, its mounted modules, and whether a standby amplifier is to be used.

- Step 1.** Click on [SF-1] or [Slot 1 – 10] on the Configuration screen.  
The [SF Properties] window will open.

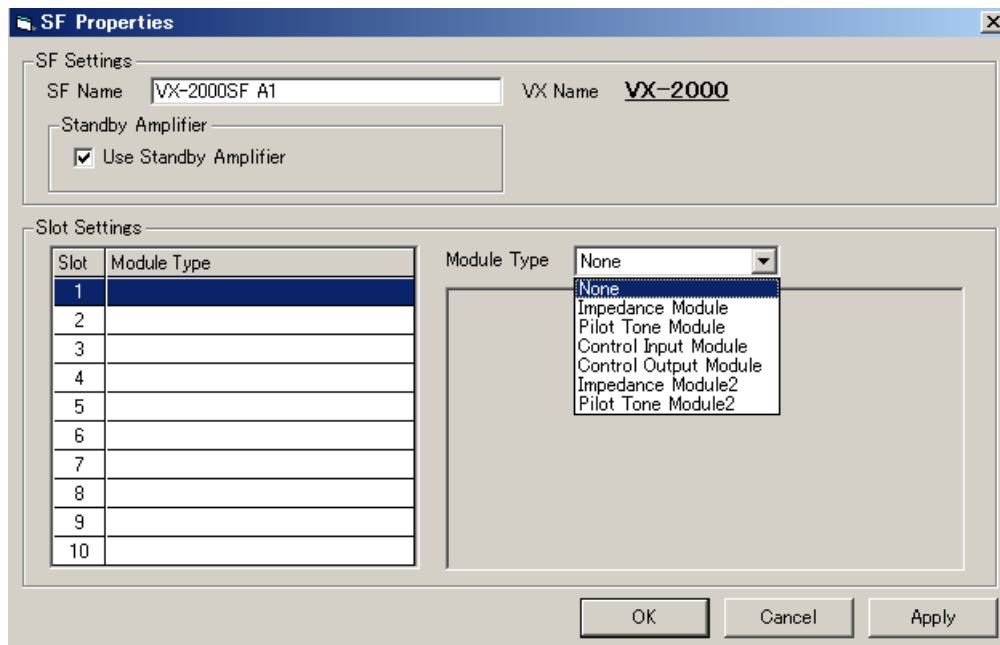

- Step 2.** Change the VX-2000SF's name if necessary.

- Step 3.** When a standby amplifier is used for the VX-2000SF unit, tick the [Use Standby Amplifier] checkbox.

- Step 4.** Select the type of module to be inserted into each slot.

- 4-1.** Select and click on the slot to be set.

The entire selected line will be highlighted, indicating that setting is possible.

*Continued on next page*



4-2. Select the module to be used from [Module type].  
Different screens are displayed as follows depending on the selected module type.

- 1) None (Default setting)
- 2) Impedance Module

Refers to the VX-200SZ Impedance Detection module.

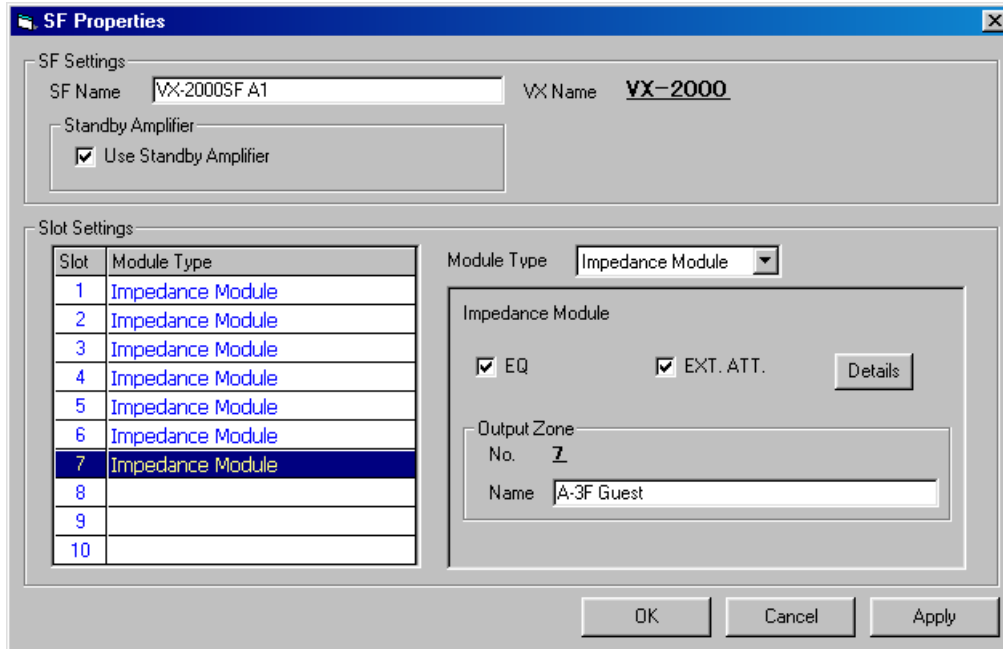

- EQ: When using the VX-200SE Equaliser Card, tick this checkbox.

- EXT. ATT.: When using an external attenuator, tick this checkbox.  
Clicking on the [Details] button will cause the Impedance Monitoring Setting window to open.

Select and enter the "Start time," "Interval" and "Interval unit." After setting completion, click on the [Apply] button to save the set contents and click on the [OK] button to close the window.

**Note:** The set interval value is equally applicable to all impedance modules that use the external attenuator.

- Output Zone: Enter a zone name.

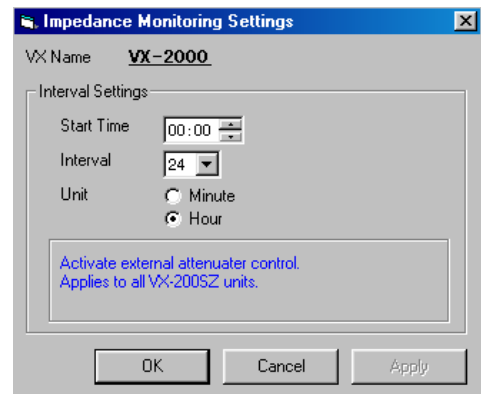

*Continued on next page*

## 3) Pilot Tone Module

Refers to the VX-200SP Pilot Tone Detection module.

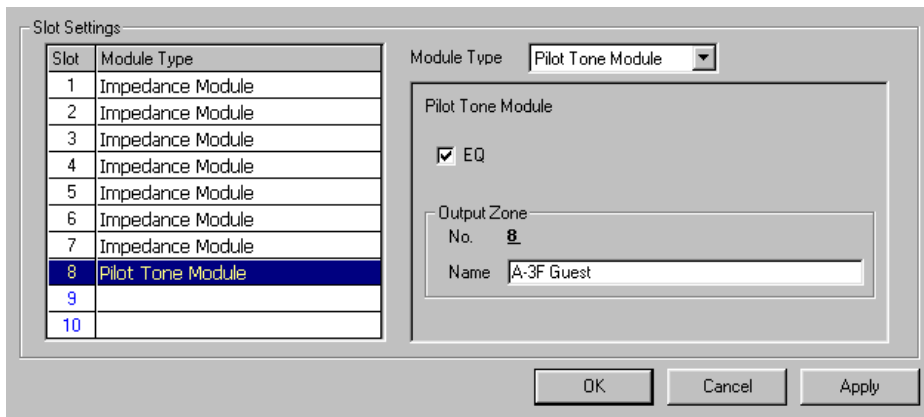

- EQ: When using the VX-200SE Equaliser Card, tick this checkbox.
- Output Zone: Enter a zone name.

## 4) Control Input Module

Refers to the VX-200SI Control input module.

The control input numbers assigned to the control input modules are displayed.

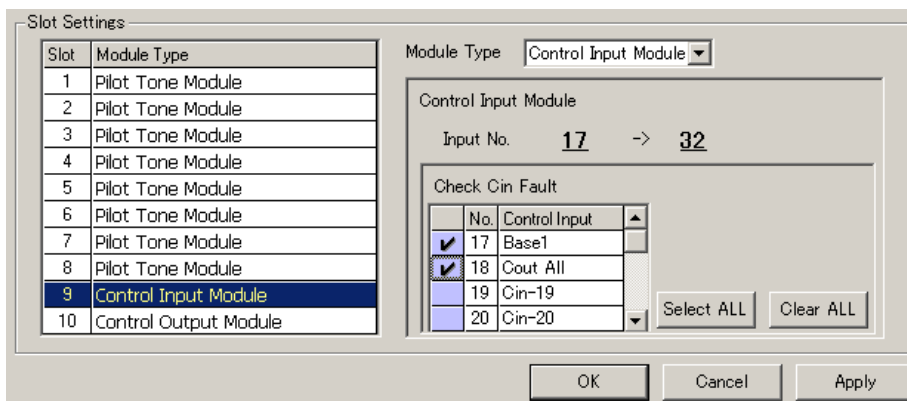

## 5) Control Output Module

Refers to the VX-200SO Control Output module.

The control output numbers assigned to the control output modules are displayed.

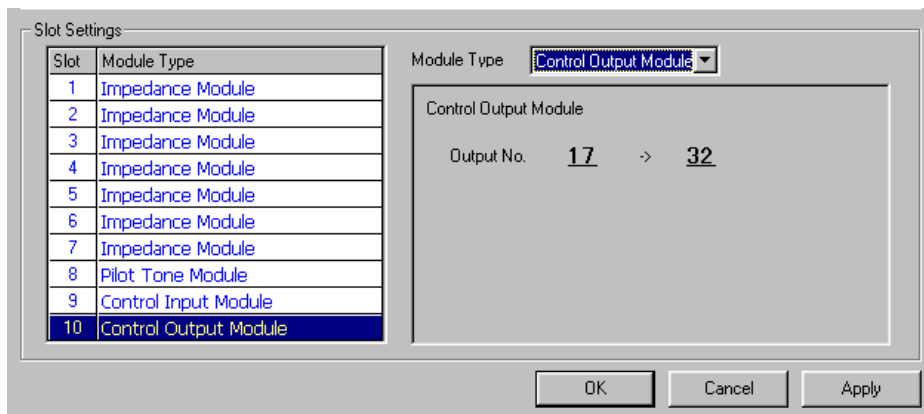

Continued on next page

- Step 5.** After all settings are complete, click on either the [Apply] or [OK] button. Setting contents will be updated, and the [SF Properties] window closed. Set module model numbers will be displayed on the Configuration screen, with the power amplifier, speaker and control I/O terminal numbers being displayed on the right-hand side of VX-2000SF.

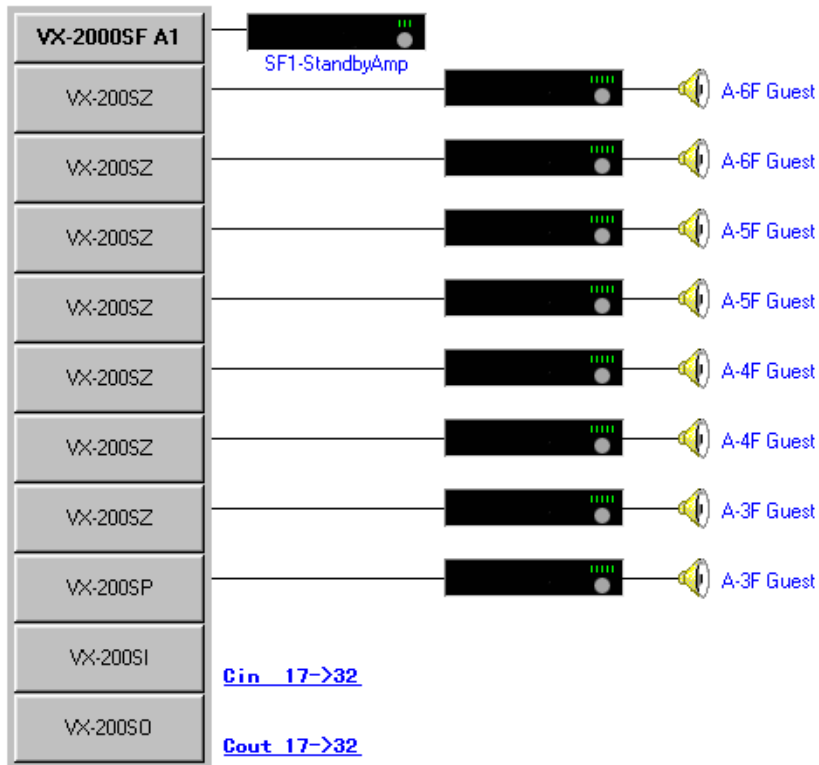

**[VX-2000SF Unit ID Number]**

The number on the right-hand side above each VX-2000SF symbol indicates the Unit ID number. Be sure to match the actual VX-2000SF ID number with the on-screen number. For details, refer to p. 8-26.

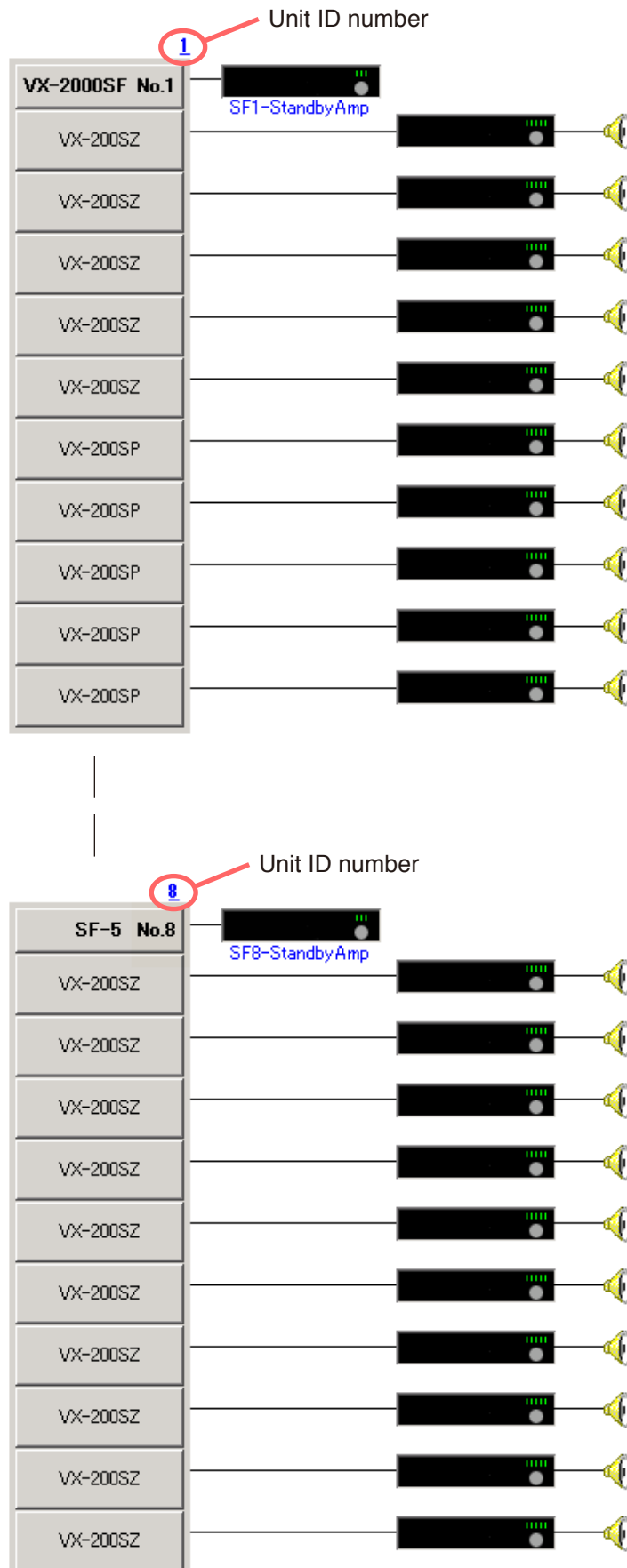

**[Pop-up menu operation to change the VX-2000SF configuration]**

The following operations can be performed on the Configuration screen as well. Click the right mouse button over the desired equipment symbol. Since the menu is displayed, select the operation.

- SF expansion and deletion, and opening Properties.

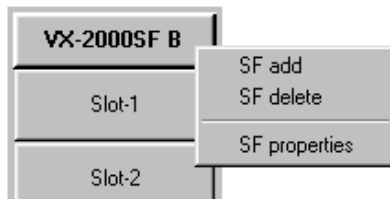

- Standby amplifier deletion



- SF module deletion and use/disuse of an equaliser

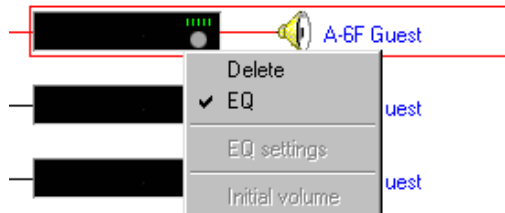

## 7.2. Control Output Name Setting

Assign a name to the control output terminal.

- Step 1.** Click on the [Control Output] button on the Configuration screen.  
[Control Output Name Setting] window will open.

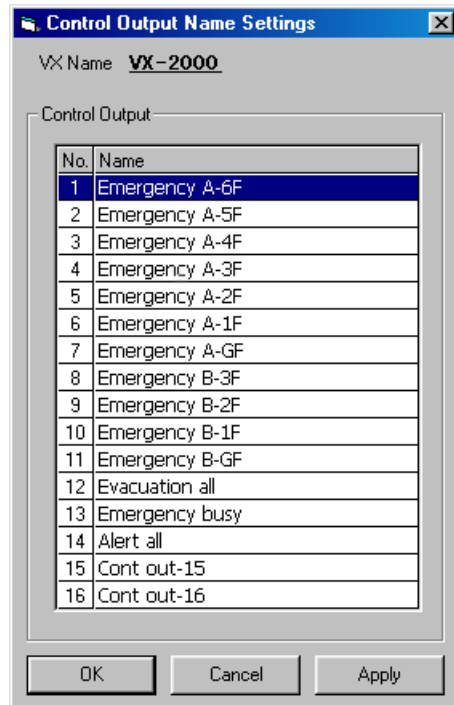

- Step 2.** Click on the line to be changed, and the line is highlighted. Click on the line again.  
The left-hand cell changes to yellow, indicating that a name can be entered.

- Step 3.** After the change is complete, click on the [Apply] button to save the settings and click on the [OK] button to close [Control Output Name Settings] window.

### 7.3. VX-2000 Properties Settings

Set the VX-2000's name, drive mode, the number of EV-200 units to be used, internal timer operation, and the type of module(s) mounted.

- Step 1.** Click on the VX-2000's name indicated button or [Slot 1 – 8] on the configuration screen.  
The [VX Properties] window will open.

- Step 2.** Change the name of the VX-2000, if necessary.

- Step 3.** Select the drive mode.

- [Normal]: Normal operation mode.
- [Economy]: Automatically switches off the power to the amplifier when not in use.

- Step 4.** Select the number of EV-200 units to be mounted in the VX-2000 from the Option EV Select pull-down menu.

- [None]: No unit mounted.
- [EV1]: 1 unit mounted.
- [EV1&EV2]: 2 units mounted.

- Step 5.** When using the internal timer, tick the [Enable Timer] checkbox.

*Continued on next page*

**Step 6.** Select the type of input modules to be used with the VX-2000.

**6-1.** Select and click the corresponding slots to be used.

The entire selected line is highlighted, indicating setting is possible.

**6-2.** Select the type of input module.

Different screens will be displayed depending on the type of module selected.

1) [None] (default): Select when no module is used.

2) [VX-200XR] (Remote Microphone Input module): Select when connecting the RM-200XF or RM-200X Remote Microphone.

**Note**

More than one Remote Microphones can be connected to a single VX-200XR module. Their number, however, cannot be set in this step.

For expanding the Remote Microphones, refer to [p. 7-25](#).

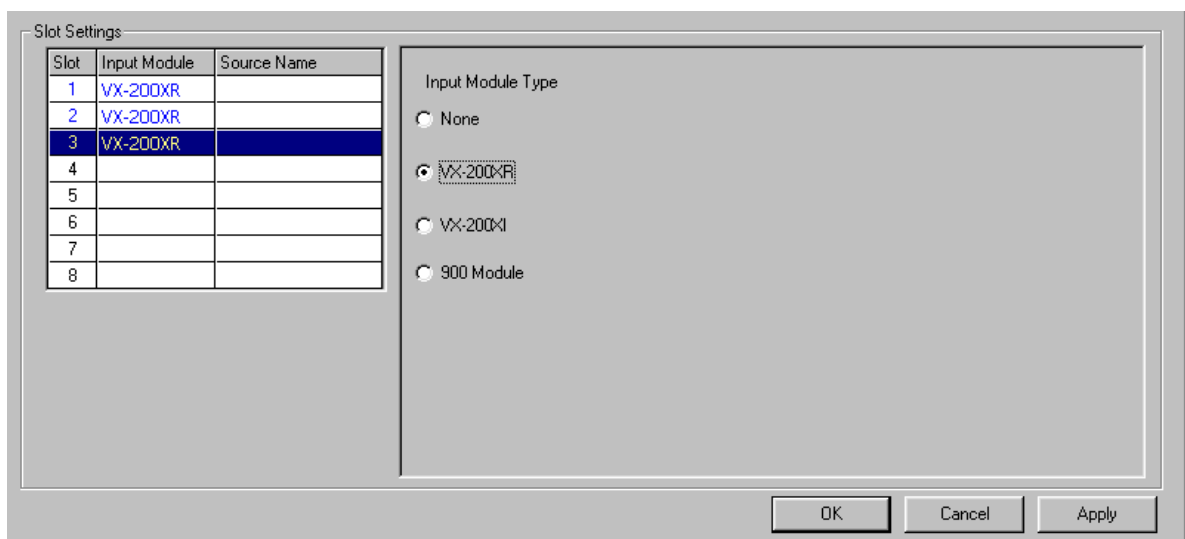

*Continued on next page*



## 3) [VX-200XI] (Audio Input module with control input):

Select when connecting the Remote Microphone with a control input, such as the PM-660U.

Slot Settings

Slot	Input Module	Source Name
1	VX-200XR	
2	VX-200XR	
3	VX-200XR	
4	VX-200XI	Tel Device
5	U-01R	BGM 1
6	U-01R	BGM 2
7	U-01R	Wireless Mic
8		

Input Module Type

None

VX-200XR

VX-200XI

900 Module

VX-200XI Control Input

Source Name: Tel Device

No.	Output Zone
11	A-1F Hallway
12	A-1F Conferen
13	A-GF Lobby
14	A-GF Bar
15	A-GF Restaurar
<input checked="" type="checkbox"/>	16 A-Staff area
17	A-Stairs/corridc
18	B-3F Guest
19	B-3F Guest
20	B-2F Guest

Select ALL Clear ALL

No.	Control Output
1	Emergency A-t
2	Emergency A-5
3	Emergency A-4
4	Emergency A-3
5	Emergency A-2
6	Emergency A-1
7	Emergency A-0
8	Emergency B-3
9	Emergency B-2
10	Emergency B-1

Select ALL Clear ALL

OK Cancel Apply

- Enter an identifying sound source name.
- Select the zones to which the selected source will be broadcast.
  - Double-clicking on the leftmost blue box of the zone list causes the corresponding zone to be marked with a tick.
  - All zones are marked with a tick if the [Select ALL] button is pressed.
  - The tick marks are deleted from all zones if the [Clear ALL] button is pressed.
- Select the control output to be activated when this sound source is broadcast.
  - Double-clicking on the leftmost blue box of the control output list causes the corresponding output to be marked with a tick.
  - All control outputs are marked with a tick if the [Select ALL] button is pressed.
  - The tick marks are deleted from all control outputs if the [Clear ALL] button is pressed.

## 4) [900 Module]: Select when connecting music output equipment, such as a CD or cassette player. The screen for name entry and module selection will be displayed.

Usable 900 modules: M-01F, M-01M, M-01P, M-01S, M-01T, M-03P, M-51F, M-51S, M-51T, M-61F, M-61S, M-61T, U-01F, U-01P, U-01R, U-01S, U-01T, U-03R, U-03S, U-61S, and U-61T

Slot Settings

Slot	Input Module	Source Name
1	VX-200XR	
2	VX-200XR	
3	VX-200XR	
4	VX-200XI	Tel Device
5	U-01	BGM 1
6	U-01	BGM 2
7	U-01	Wireless Mic
8		

Input Module Type

None

VX-200XR

VX-200XI

900 Module

Source Name: BGM 2

Module: U-01

Use this source for BGM

OK Cancel Apply

- Enter an identifying sound source name.
- Select the 900 module to be used.
- When using the sound source for BGM broadcast, tick the [Use this sound source for BGM] checkbox.

**Step 7.** After completing the settings of Slots 1 – 8, click on the [Apply] button to save the settings and click on the [OK] button to close the screen.

## 7.4. Remote Microphone Properties Settings

When the [VX Properties] screen is closed, if there is an input module set to [VX-200XR], the [RM Properties] window will open. Here, set the type of Remote Microphone to be used, the type of broadcast, the number of expansion units, and a password.

### Note

The following message is displayed if the [Main Unit] tab is clicked in the RM Properties screen: "This RM function key setting cannot be changed during configuration setting."

Click on the [Main Unit] tab when assigning function to individual keys on the remote control unit.

The types of modules assigned to the VX-2000's slots are displayed on the screen, and icons for the Remote Microphone, sound source, and other connected equipment are displayed to the left of the [VX-2000] column.

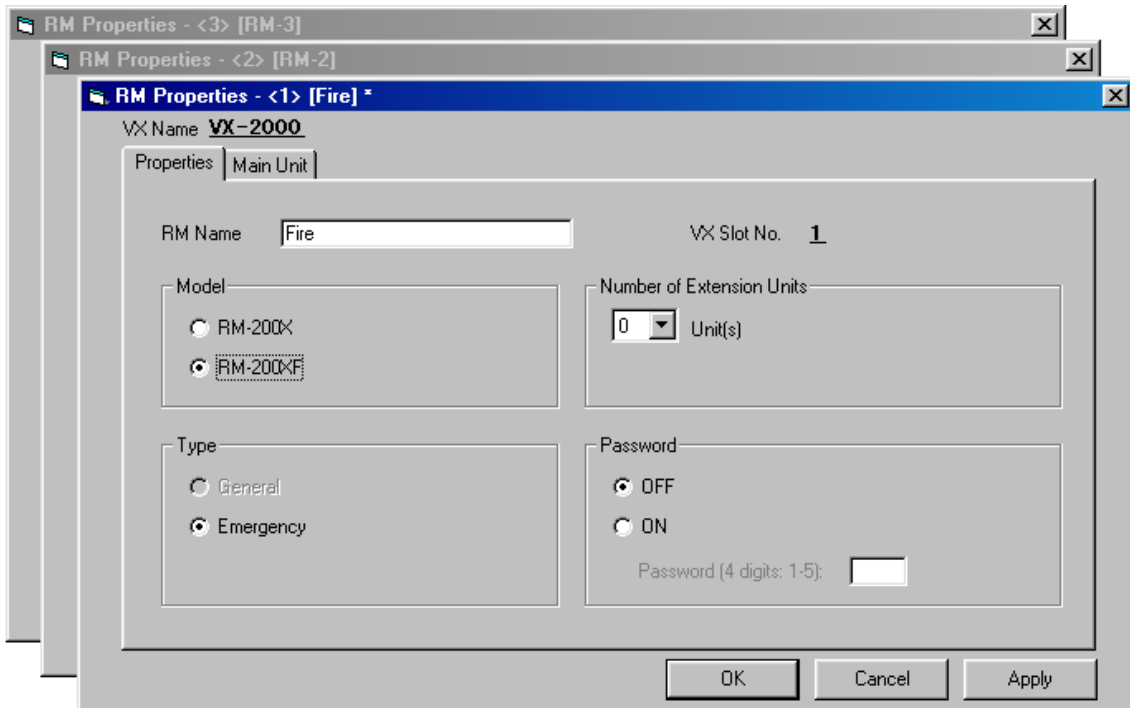

**Step 1.** If necessary, enter a name in [RM Name] box.

**Step 2.** Select either the RM-200XF or RM-200X Remote Microphone.

- If RM-200X is selected, designate the [Type] as either [General] or [Emergency].
- If RM-200XF is selected, the [Type] is automatically set to [Emergency].

**Step 3.** When increasing the number of function keys, select the number of extension units.

**Step 4.** If necessary, enter a password.  
Select [OFF] when not using a password, and [ON] when a password is to be set.  
Enter a 4-digit password comprised of the numbers 1 – 5 in the [Password] box.

### Note

If a password has been set, the Remote Microphone cannot be operated without the password. For entering a password, refer to [p. 5-2](#).

**Step 5.** Set the [RM Properties] for any other Remote Microphones in the same way.  
Activate the window by clicking on the title bar, then perform the settings.

*Continued on next page*

**Step 6.** Press the [OK] button after completing the settings of all Remote Microphones.

The following message will then be displayed.

"Data altered in all opened properties windows will be saved and RM properties settings completed. OK?"

**Step 7.** Click on the [Apply] button to update and save the settings, and click on the [OK] button to close the [RM Properties] window. To continue the setting procedure, click on the [Cancel] button. The screen will return to the Properties settings.

### Tip

All RM properties windows can also be simultaneously closed by selecting [Edit → RM Properties Setting End] from the menu.

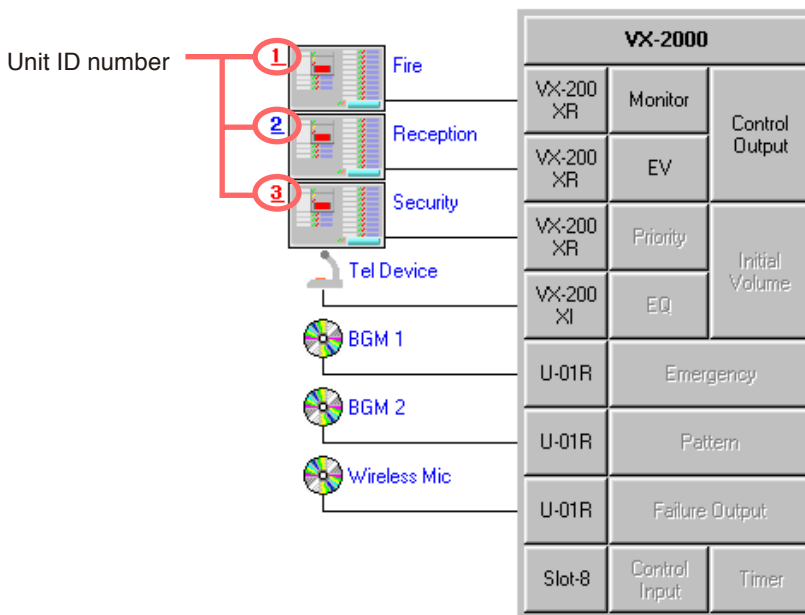

### [Remote microphone Unit ID Number]

- The number displayed on the left of the Remote microphone icon represents the Unit ID number. The Unit ID numbers of Remote Microphone set for [Emergency] broadcast type are displayed in red, while those set for [General] are displayed in blue.
- The RM-200XF or RM-200X Unit ID Number can be set by the unit's DIP switch. Make sure that the equipment Unit ID number and connection match up with those on the Configuration screen. Refer to [p. 8-3](#) for the Unit ID Number setting.

### [Pop-up menu operation to change the VX-2000SF configuration]

On the Configuration screen, erasure of the sound source and input module, and whether or not to use a sound source as BGM can be performed as well. This configuration change can be executed by clicking the right mouse button over the corresponding equipment block and selecting the operation from the pop-up menu that appears.



## 7.5. Remote Microphone (RM) Unit Expansion

Two or more Remote Microphones (RM-200X and RM-200XF) can be connected to one input module.

**Step 1.** Click the right mouse button over the icons for the Remote Microphones to be expanded.

The following menu will then be displayed.

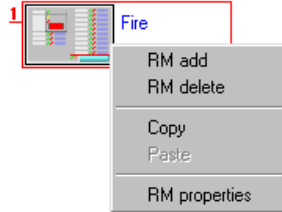

**Step 2.** Select [RM add] on the menu.

The [RM Properties] window will then open.

Set the Remote Microphone model number, broadcast type, number of extension units and password.

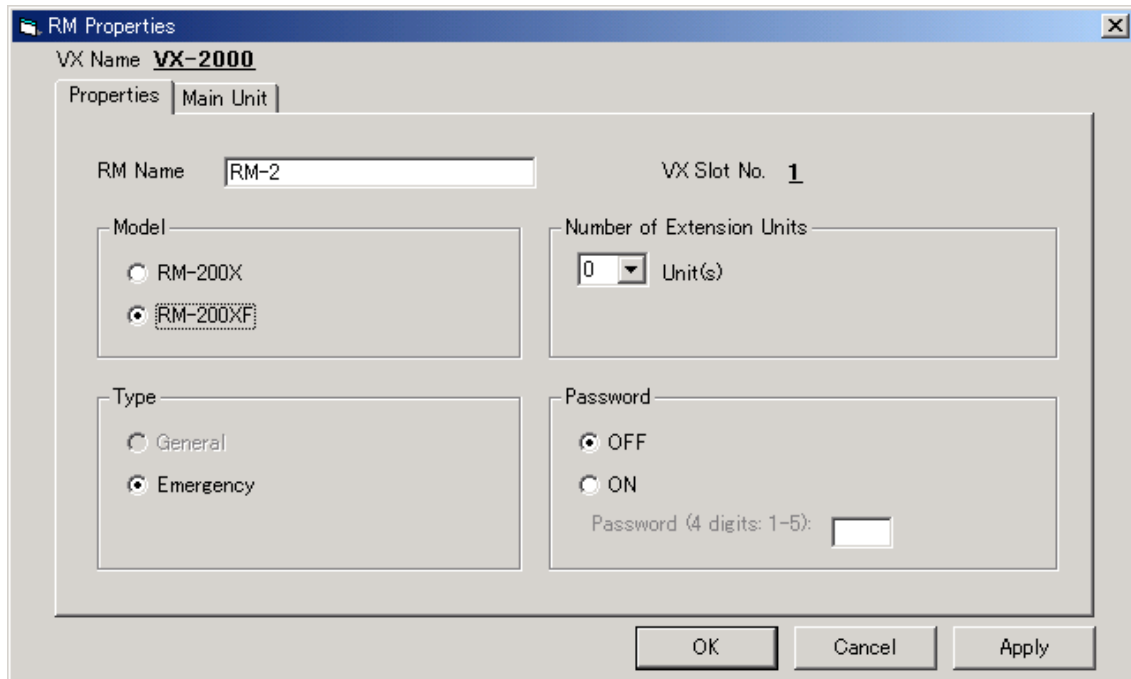

RM Properties

VX Name **VX-2000**

Properties Main Unit

RM Name  VX Slot No. **1**

Model

RM-200X

RM-200XF

Number of Extension Units

Unit(s)

Type

General

Emergency

Password

OFF

ON

Password (4 digits: 1-5):

OK Cancel Apply

*Continued on next page*

**Step 3.** Click on the [Apply] button to save the settings and click on the [OK] button.

The [RM Properties] window will close and the added Remote Microphone is displayed to the left of the first Remote Microphone icons.

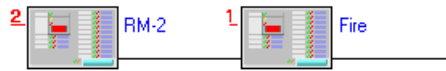

### Notes

- The expanded Remote Microphone is automatically assigned its ID number depending on the position the unit is placed into, and its subsequent ID numbers are also changed. To match both ID numbers on the software and hardware, be sure to reset the hardware ID numbers on the Remote Microphones whose software ID numbers are changed. For example, if a Remote Microphone is added to the unit of Unit ID 1, the newly added unit is assigned as Unit ID 2 and the original unit of Unit ID 2 is changed to Unit ID 3.

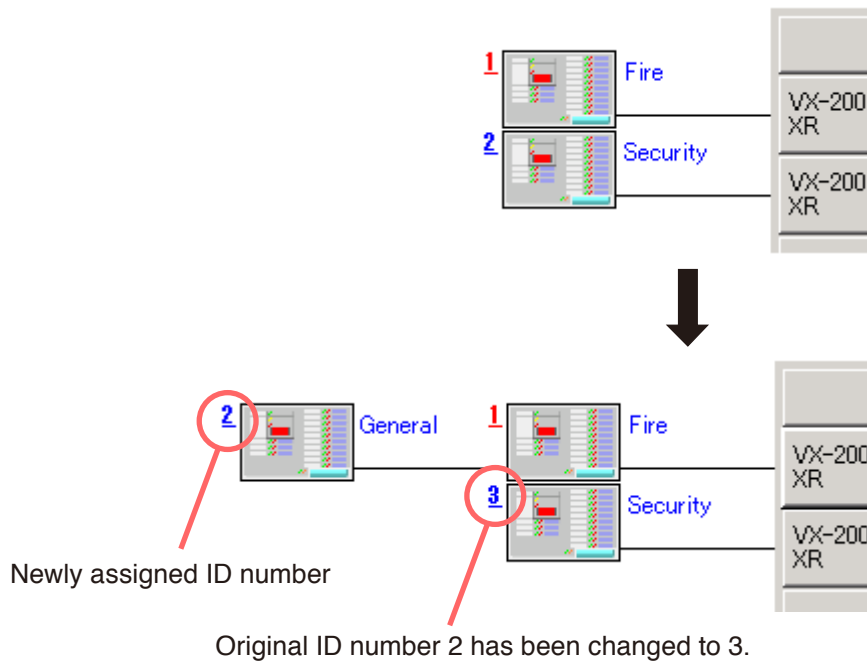

- When a Remote Microphone is deleted in the diagram, this causes its subsequent unit's ID numbers to be automatically re-assigned to compensate for the broken continuity of ID numbers. To match both ID numbers on the software and hardware, be sure to reset the hardware ID numbers on the Remote Microphones whose software ID numbers are changed.

Note that the Remote Microphone to be deleted must be the one at the leftmost position in the diagram.

For example, if the unit of Unit ID 3 is deleted, the original unit of Unit ID 4 is changed to Unit ID 3 to compensate for the lack of number continuity.

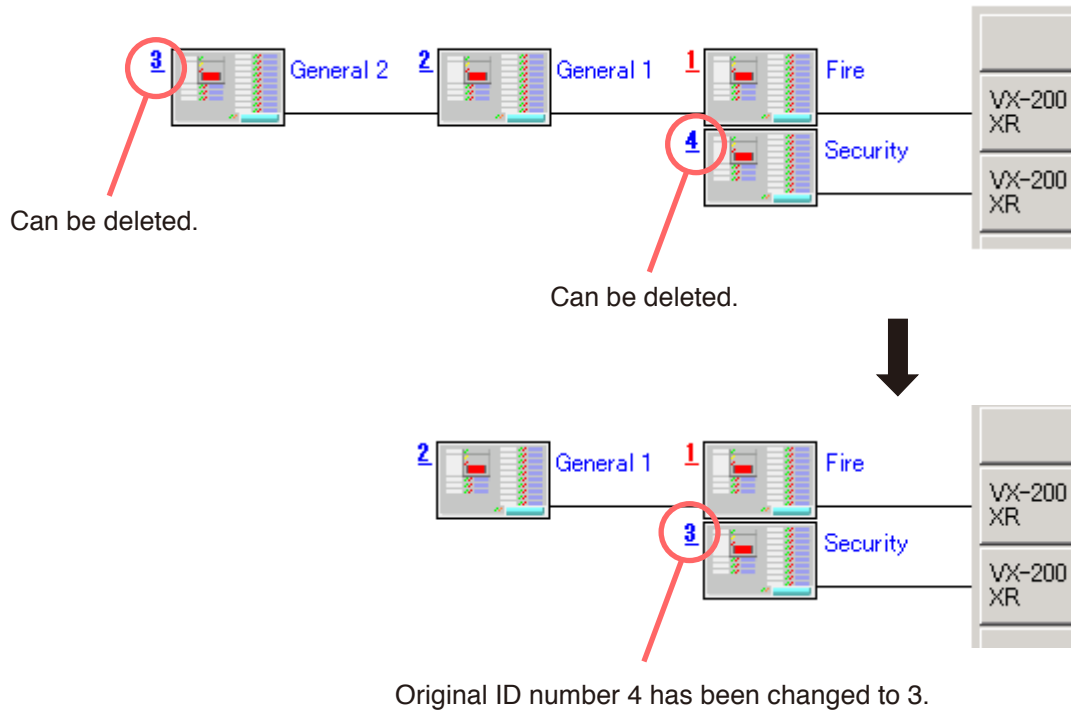

- A total of up to 8 RM-200X and RM-200XF can be connected per system. However, connections to individual units are limited to the following:

Designated for Emergency use: Up to 4 units in total of the RM-200XFs and RM-200Xs

Designated for General use: Up to 8 units of RM-200Xs only

There are 2 different connection methods:

one is to connect individual units to each module, and the other to connect multiple units to a single module.

#### [About the other menus]

- RM Delete: Removes the Remote Microphone from the assigned system configuration.
- Copy: Copies the setting contents.
- Paste: Pastes the copied setting contents into other Remote Microphones.
- RM Properties: Opens the RM Properties window.

## 7.6. Electronic Voice File (EV) Unit Message Types

Clicking on the [EV] button on the Configuration screen opens the [EV Message Settings] window.

### [When Using a Single EV Unit.]

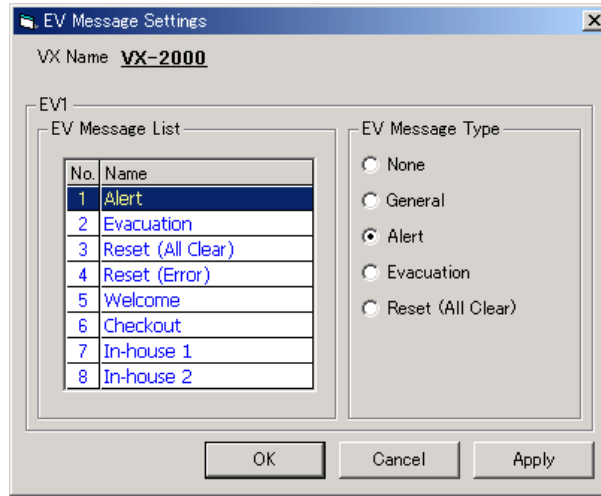

**Step 1.** Click on the desired EV message Name to highlight the selected line.

**Step 2.** Select the [EV message type].

**Step 3.** After setting completion, click on the [Apply] button to save the settings and click on the [OK] button to close the [EV Message Settings] window.

### [When Using 2 EV Units]

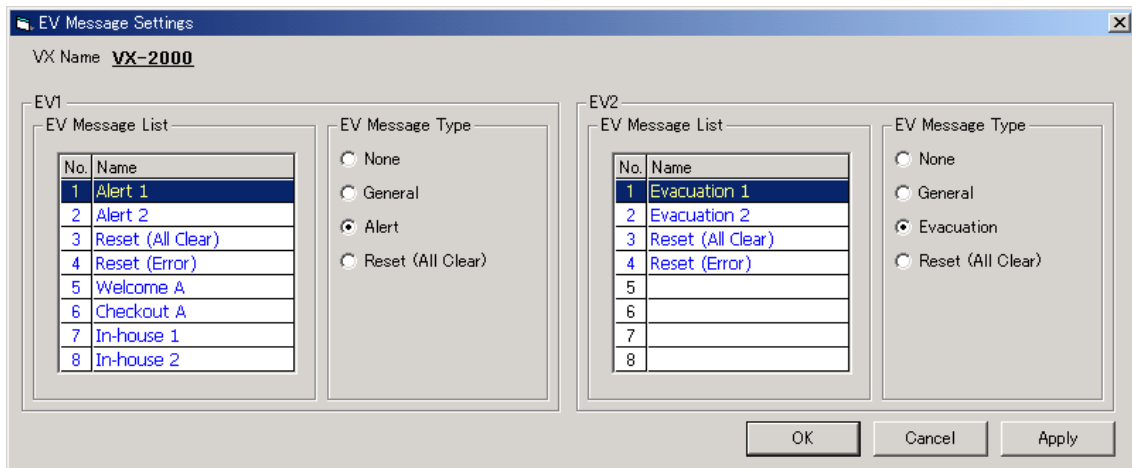

**Step 1.** Click on the desired EV message Name to highlight the selected line.

**Step 2.** Select the [EV message type].

**Step 3.** After setting completion, click on the [Apply] button to save the settings and click on the [OK] button to close the [EV Message Settings] window.

#### Note

EV message names can be changed. Select a line to rename, then click on it again, and the name can be changed.

## 7.7. Monitor Settings

### Step 1. Set battery check interval.

Set the interval time long enough to enable the check of sealed lead backup storage batteries for sufficient charge voltage.

- 1-1. Click the [Monitor] button on the Configuration screen.  
The [Monitor Settings] window will open.

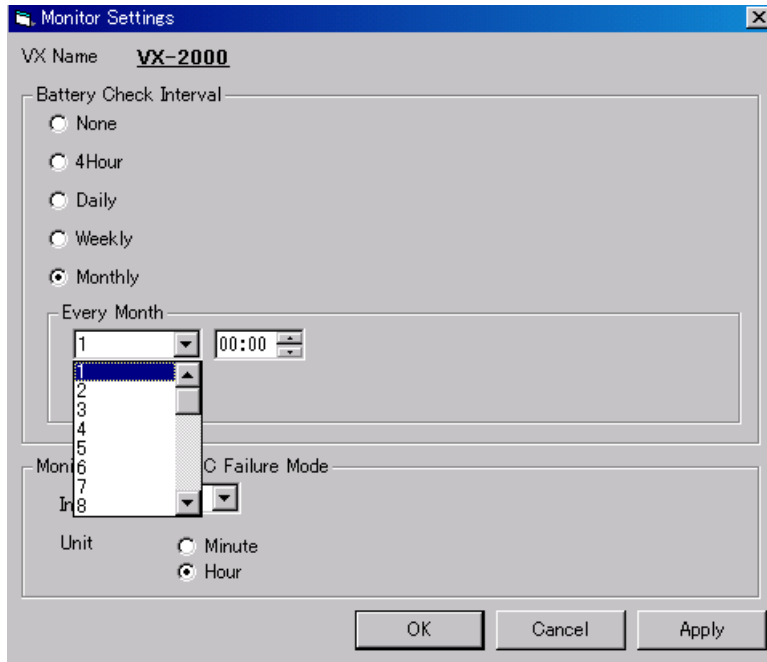

- 1-2. Set the time interval for checking the batteries.
  - [None]: Select this setting if the system uses no backup battery.
  - [4Hour]: Checks the batteries every 4 hours for EN 54-4.
  - [Daily]: Checks the batteries every day.
  - [Weekly]: Checks the batteries every week on the designated day.
  - [Monthly]: Checks the batteries every month on the designated date.

#### Notes

- If "29," "30," or "31" is selected, the following message will be displayed.  
"Battery is checked on the last day of the month if the designated date does not fall within the days of the month."

For example, when the date "30" is set, the battery check is performed on 28th or 29th of February or on 30th of other months.

### Step 2. Set the time interval for monitoring the system during AC power failure.

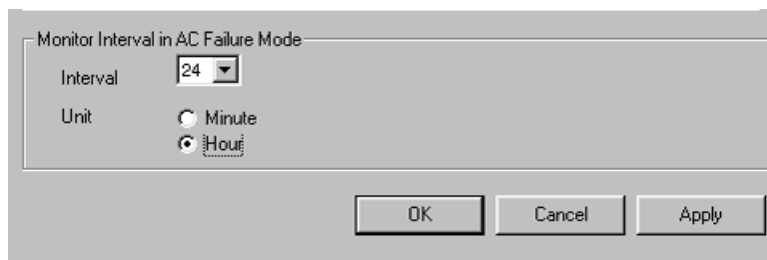

- 2-1. Set the monitoring interval.  
The monitoring interval can be set for once every 1 – 24 hours in 1-hour increments or for 1 – 60 minutes in 1-minute increments.
- 2-2. After setting completion, click on the [Apply] button to save the settings and click on the [OK] button to close the [Monitor Settings] window.



## 8. SYSTEM SETTING MODE

Select [Edit → System Setting Mode] from the menu.

Alternately, the  button on the toolbar may be clicked to switch the display to the System Setting mode.

Here, set the broadcast priorities, initial sound volume, and equaliser.

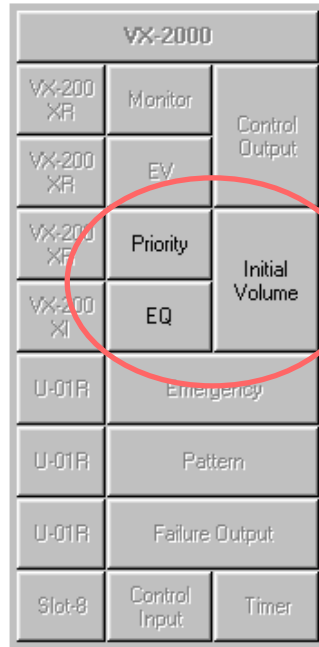

### 8.1. Broadcast Priority Settings

Click on the [Priority] button on the Configuration screen, and the [Priority Settings] window will open. Broadcast priorities are predetermined depending on content.

These are arranged as follows in order of highest to lowest priority: [Emergency RM announcement], [Emergency EV message], [General-purpose broadcast] and [BGM]. It is also possible to set priorities for individual broadcast contents.



*Continued on next page*

### 8.1.1. Emergency RM

When the Priority Settings window opens, the Emergency RM priority display will appear.

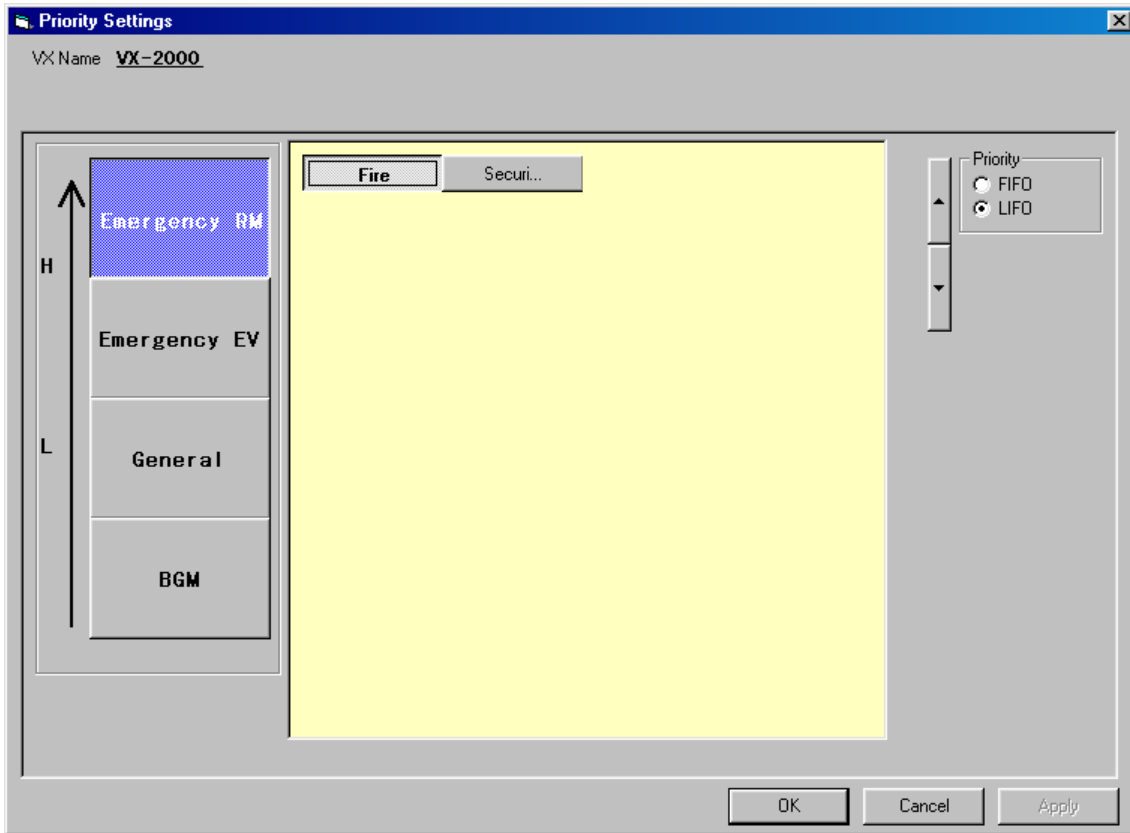
In the [Emergency RM] settings window, those Remote Microphones set for [Emergency/General Purpose] in the [RM Properties] window are displayed. All are initially displayed with the same level of priority.



**Step 1.** Select a Remote Microphone and change its priority level by pressing the Up (  ) and Down (  ) buttons.

**Step 2.** If the same priority level is assigned to more than one Remote Microphone, select either [FIFO] (first in, first out) or [LIFO] (last in, first out) priority settings in case simultaneous broadcasts are made.

- FIFO: Priority is given to the first broadcast made. Other subsequent Remote Microphones broadcasts cannot be made until the first Remote Microphone's broadcast is completed.
- LIFO: Priority is given to the most recent broadcast, which overrides any Remote Microphone broadcasts that are currently in progress.

### 8.1.2. Emergency EV

Clicking on the [Emergency EV] button displays the emergency messages set in the [EV Message Settings] window. Emergency message priorities are predetermined, and cannot be changed. These are arranged as follows in order of highest to lowest priority: [Reset], [Evacuation], and [Alert].

It is possible to have several of the same sort of emergency messages. Although their priority levels are the same, when simultaneous broadcasts are made, they are always broadcast on a last in, first out (LIFO) basis.

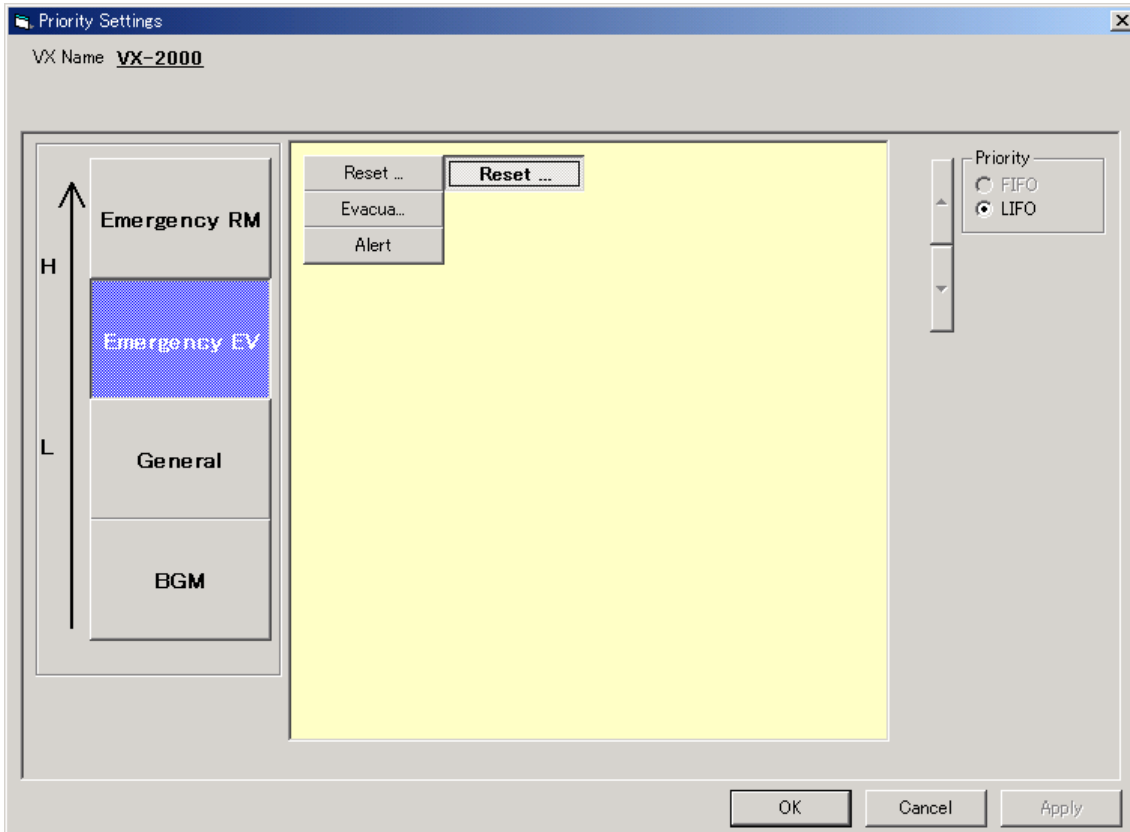



### 8.1.3. General (General-Purpose Broadcast)

Clicking on the [General] button displays all Remote Microphones set for general-purpose broadcast only in the [RM properties] window, general-purpose EV messages, and sound sources not set for BGM\*. All are initially displayed with the same level of priority.

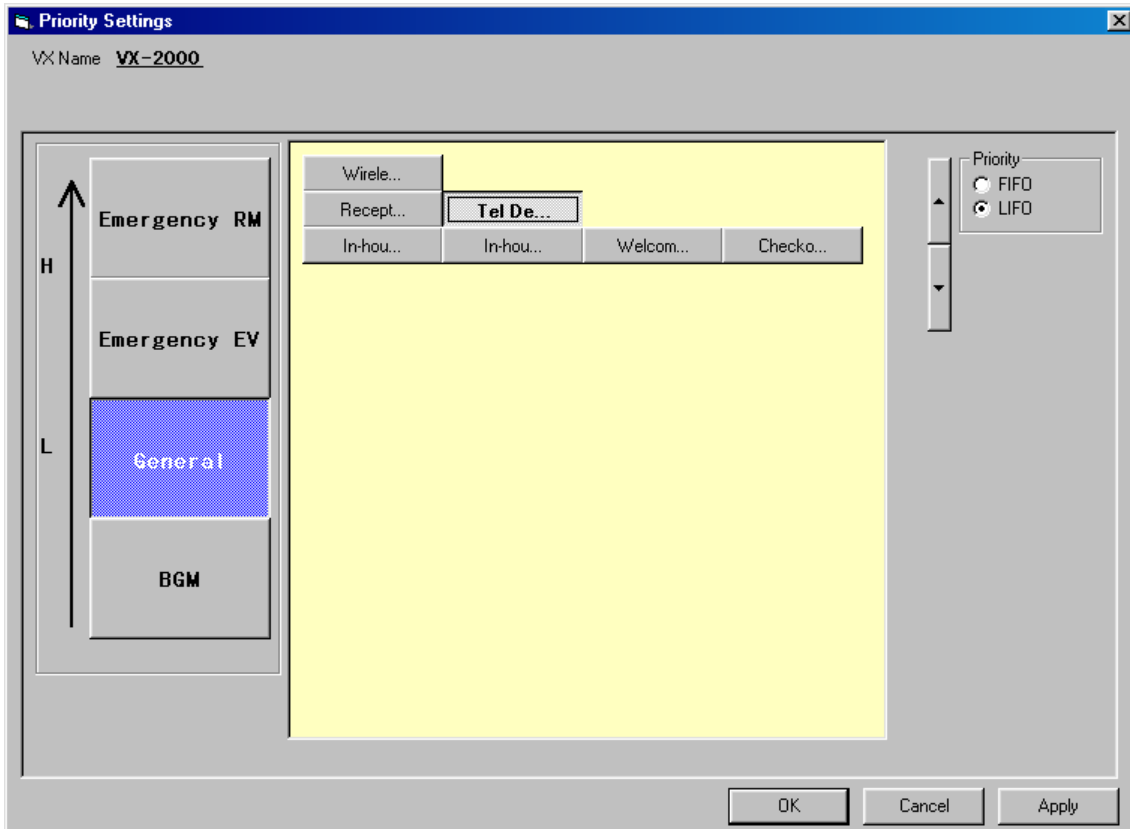
\* When the "Use this source for BGM" checkbox in the 900 module setting window is not ticked, the sound source broadcast takes precedence over BGM sources. For the VX-2000 input slot settings, refer to [p. 7-21](#).



**Step 1.** Select a Remote Microphone, general-purpose message, or sound source, and change its priority by

pressing the Up (  ) and Down (  ) buttons.

**Step 2.** If the same priority level is assigned to more than one sound source, select either [FIFO] (first in, first out) or [LIFO] (last in, first out) priority settings in case simultaneous broadcasts are made.

- FIFO: Priority is given to the first broadcast made. Subsequent broadcasts cannot be made until the first all-zone broadcast is completed.
- LIFO: Priority is given to the most recent broadcast, which overrides any Remote Microphone, general-purpose message or sound source broadcasts currently in progress .

#### 8.1.4. BGM

The BGM sound sources set in the [VX Properties] window are displayed by clicking on the [BGM] button. Because BGM is certain to be broadcast to different zones, there is no priority assignment between BGM broadcasts.

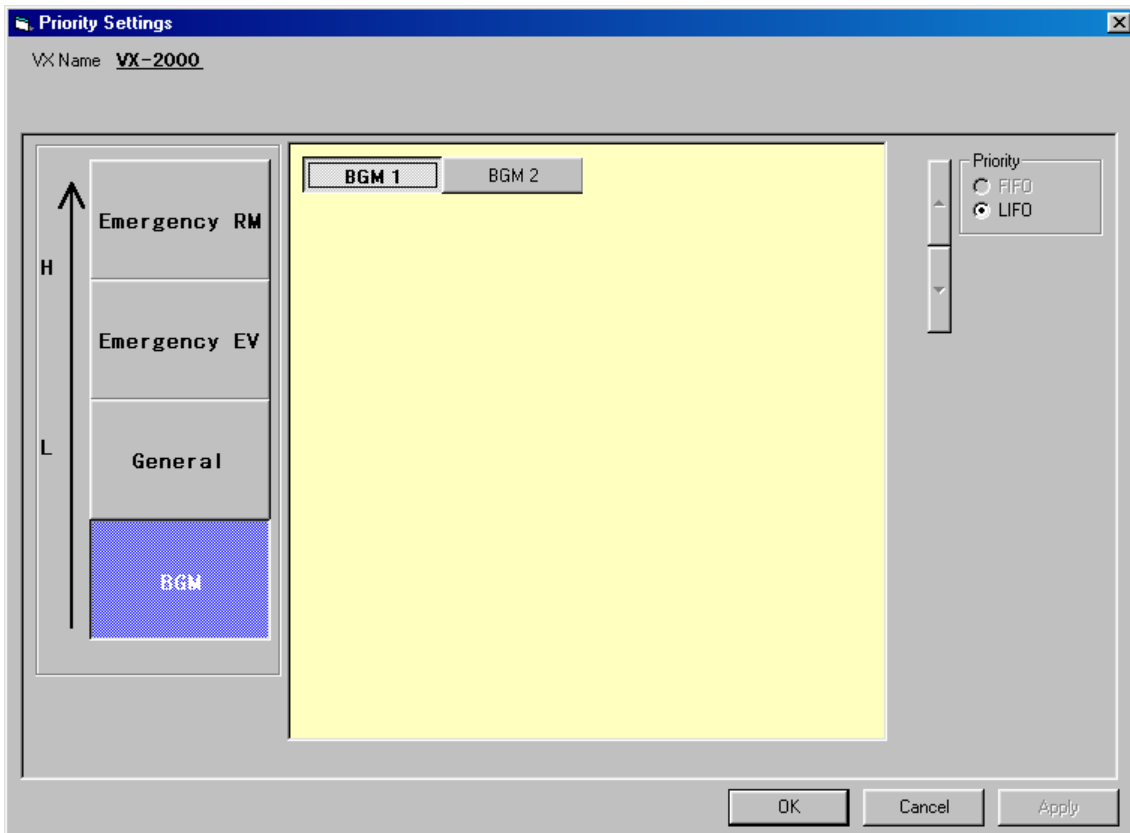

Click on the [Apply] button to save the settings and click on the [OK] button to close the [Priority Settings] window.

## 8.2. Initial Volume Settings

Clicking on the [Initial Volume] button on the Configuration screen displays the [Initial Volume Settings] window.

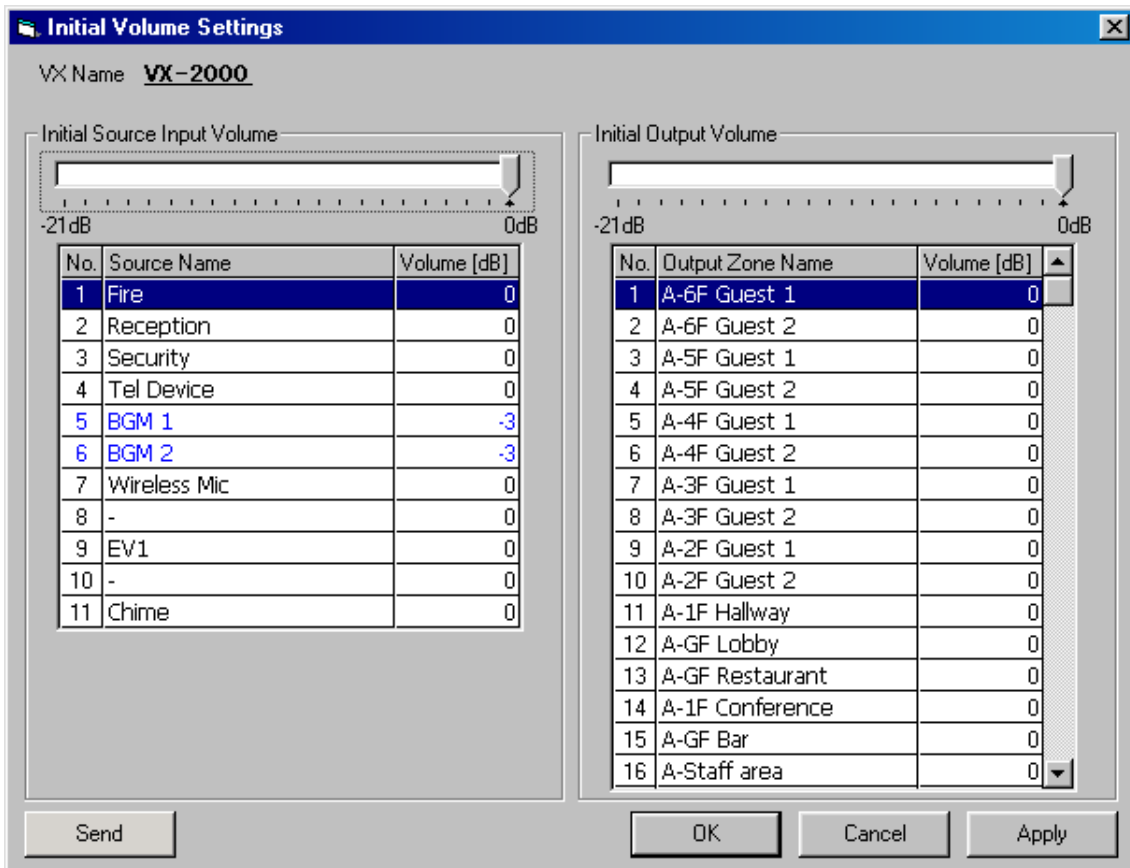

### 8.2.1. Initial source input volume settings

The initial sound volume can be set for all sound source modules. Source component names are displayed on the left side of the window.

**Step 1.** Click on the name of the component for which the initial volume is to be set. The selected line will be highlighted.

**Step 2.** Drag the top volume control knob with the mouse to set the initial volume.

The sound volume can be set for 0 to -21 dB in 1 dB step.

This setting can also be performed by directly entering a numerical value in the volume cell.

### 8.2.2. Initial output volume settings

Output zones are displayed on the right side of the window.

**Step 1.** Click on the zone to be set.

The selected zone line will be highlighted.

**Step 2.** Drag the top volume control knob with the mouse to set the initial volume.

The sound volume can be set for 0 to -21 dB in 1 dB step.

This setting can also be performed by directly entering a numerical value in the volume cell.

**Step 3.** Press the [Apply] button to save the settings and click on the [OK] button to close the [Initial Volume Settings] window.

#### Note

When connected online, initial volume settings can be varied by pressing the [Send] button on the [Initial Volume Settings] window. This makes it possible to output sound and set the volume to adequate initial levels during system installation. For details, refer to [p. 10-15](#).

#### [Pop-up menu operation to set the initial volume]

The [Initial Volume Settings] window can also be opened at the Configuration screen by clicking the right mouse button over the corresponding equipment block and selecting [Initial Volume] from the pop-up menu that appears.



### 8.3. Equaliser Settings

Set the VS-200SE Equaliser Card to be mounted in the VX-200SP or VX-200SZ Failure Detection module.

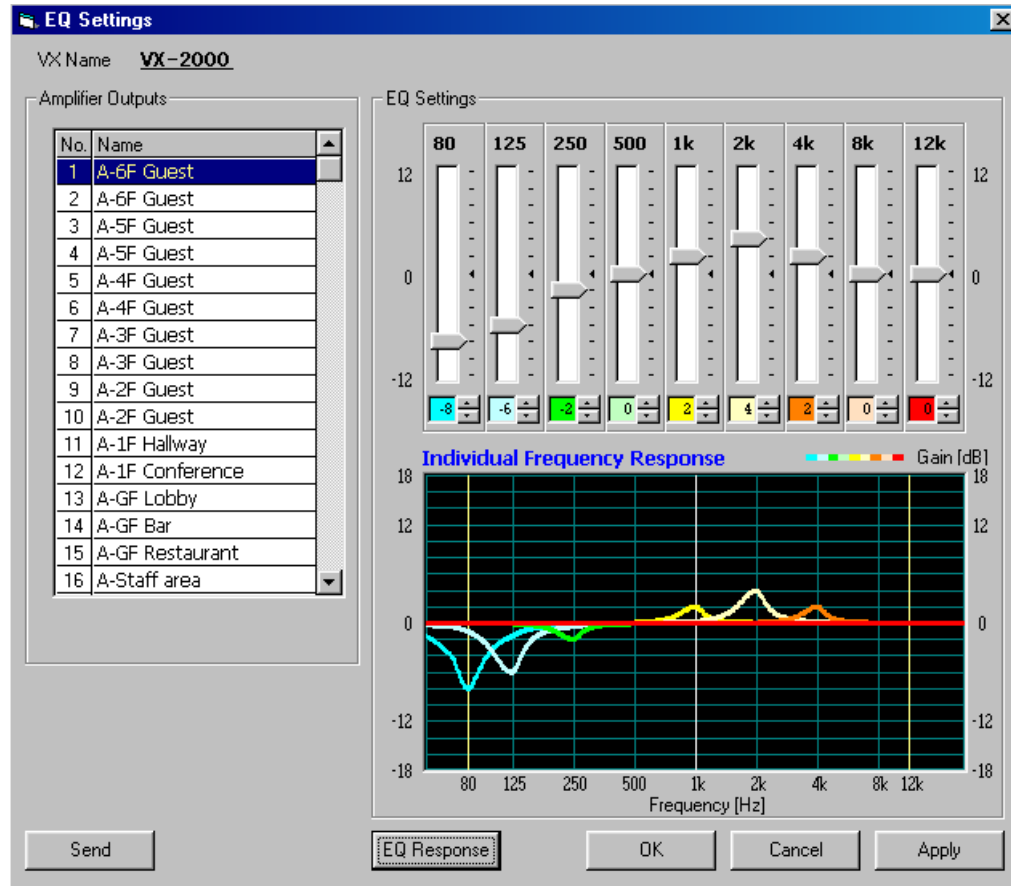

**Step 1.** Click on the [EQ] button on the Configuration screen.

The [EQ Settings] window will be displayed. The output zones for which equalisation was set in the [SF Properties] window will be displayed on the left side of the window.



**Step 2.** Click on the name of the amplifier output for which the equalisation is to be set, highlighting the entire selected.

**Step 3.** Set the equaliser.

Drag the volume control knob with the mouse to set the gain for each centre frequency. The gain can be changed within the variable range of  $\pm 12$  dB in 2 dB step by either clicking on the Up (  ) and Down (  ) buttons located next to the value or directly entering the numerical value.

In the figure, uncombined input and output characteristics are shown on the graph.

Combined input and output characteristics can also be displayed with the [EQ Response] button.

The display alternates between these 2 modes as the [EQ Response] button is clicked.

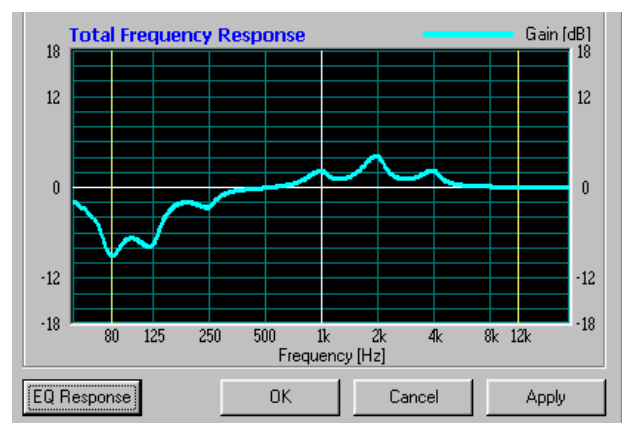

*Continued on next page*



**Step 4.** After completing the equaliser settings for all outputs, click on the [Apply] button to save the settings and click on the [OK] button to close the [EQ settings] window.

### Notes

- When connected online, characteristics can be varied by pressing the [Send] button on the [EQ Settings] window. This makes it possible to output sound and set the equalisation to adequate initial levels during system installation. For details, refer to p. 10-16.
- The EQ settings also have a memory function with 2 storage settings: A and B. Optimum settings can be achieved by recalling Memory A or B and comparing its sound with the current settings.

The floating menu shown superimposed over the frequency characteristics chart in the figure below is displayed when the right mouse button is clicked on the chart.

- Registration (Memory A, Memory B): Stores settings in either Memory A or B.
- Read Memory A: Recalls settings from Memory A.
- Read Memory B: Recalls settings from Memory B.
- Bypass: Bypasses the equaliser.
- Flat: Returns the equaliser settings to flat characteristics.

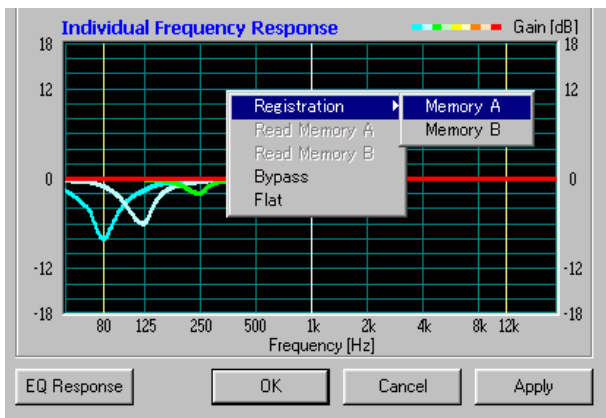

### [Pop-up menu operation for the EQ settings]

The [EQ settings] window can also be opened directly from the Configuration screen by clicking the right mouse button over the corresponding equipment block and selecting [EQ settings] from the pop-up menu that appears.

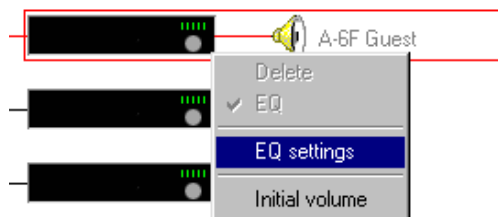

## 9. OPERATION SETTING MODE

Select [Edit → Operation Setting Mode] from the menu.

The operation setting mode can also be selected by clicking on the button on the toolbar.



Emergency broadcast, General-purpose broadcast pattern and Failure output pattern settings can all be performed here.



### 9.1. Emergency Broadcast Settings

Clicking [Emergency] on the Configuration screen will display the [Emergency Settings] window.

#### 9.1.1. When no EV units are used

The [Emergency Output] setting contents appear.

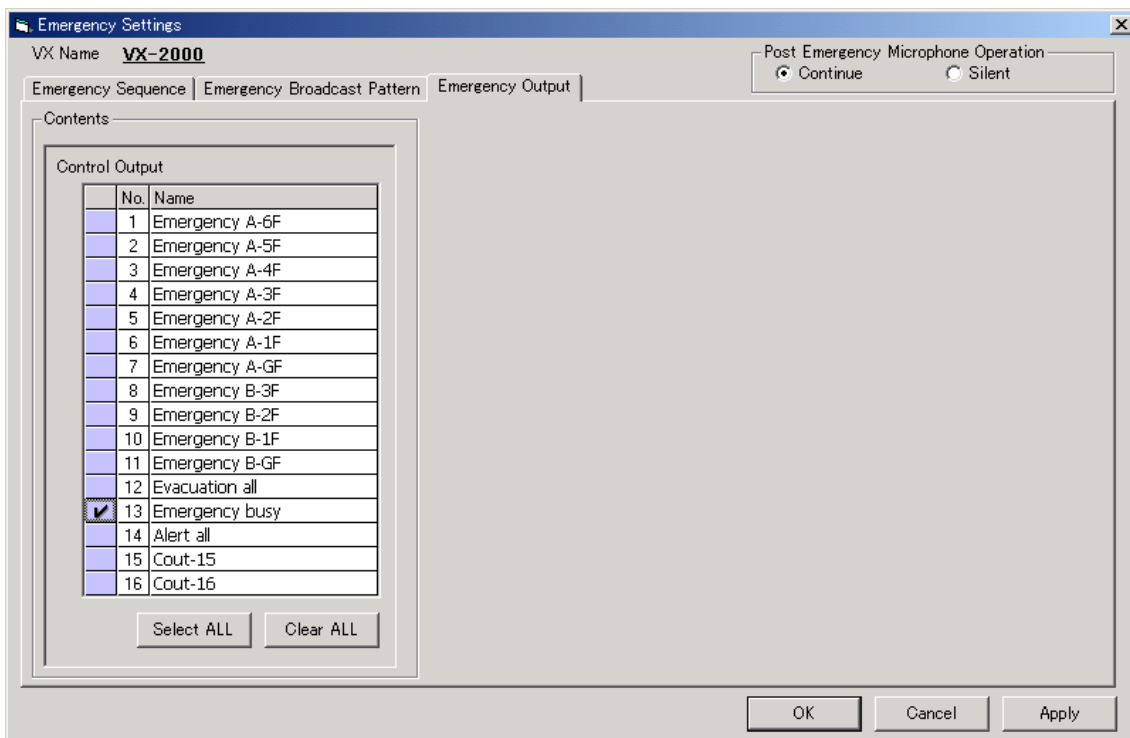

*Continued on next page*

**Step 1.** Select the control output to be activated in emergency situations.

- Double-click on the leftmost blue area of the control output list, causing a tick to appear in the selected area.
- Clicking on the [Select ALL] button will cause ticks to appear for all control outputs.
- Clicking on the [Clear ALL] button will cause all ticks to disappear from all control outputs.

**Step 2.** Click on the [Apply] button after setting completion to save the settings and click on the [OK] button to close the [Emergency Settings] window.

### Note

When no EV units are used, sequence setting and emergency broadcast pattern setting cannot be performed. Whichever the [Post Emergency Microphone Operation] is set for "Continue" or "Silent," broadcast is terminated after the Fireman's Microphone announcement because there is no basic EV broadcast.

### 9.1.2. When using a single EV unit

The [Emergency Settings] window opens, permitting up to 50 emergency broadcast patterns to be created and used.

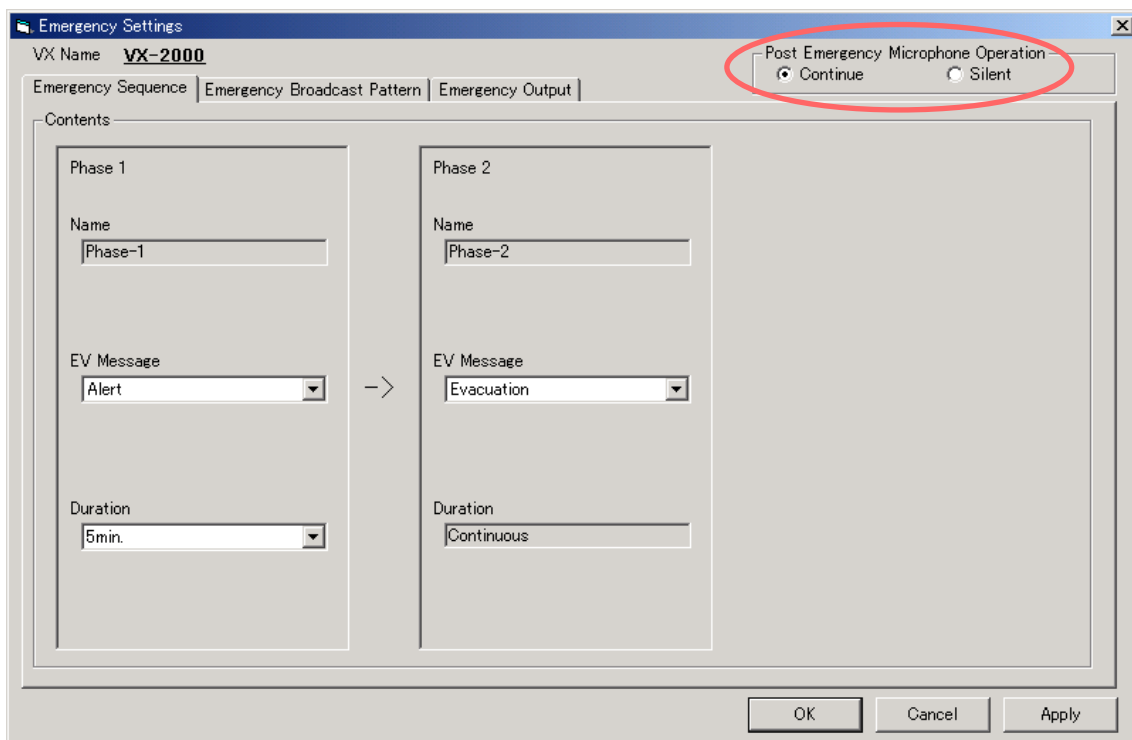

**Step 1.** Set the [Post Emergency Microphone Operation].

- [Continue]: The original EV broadcast to the designated zone(s) is restored after completion of the Fireman's Microphone announcement.
- [Silent]: The original EV broadcast is not restored after completion of the Fireman's Microphone announcement.

**Step 2.** Set the [Emergency Sequence].

- 2-1. Select either the "Alert" or "Evacuation" message for Phase 1 EV message.
- 2-2. Select the message broadcast duration for Phase 1 (1 – 20 minutes in 1-minute increments or continuous).
- 2-3. Select either the "Alert" or "Evacuation" message for Phase 2 EV message.

**Note:** If the broadcast duration for Phase 1 is set for "Continuous," Phase 2 cannot be set.

*Continued on next page*

**Step 3.** Click on the [Emergency Broadcast Pattern] tab.

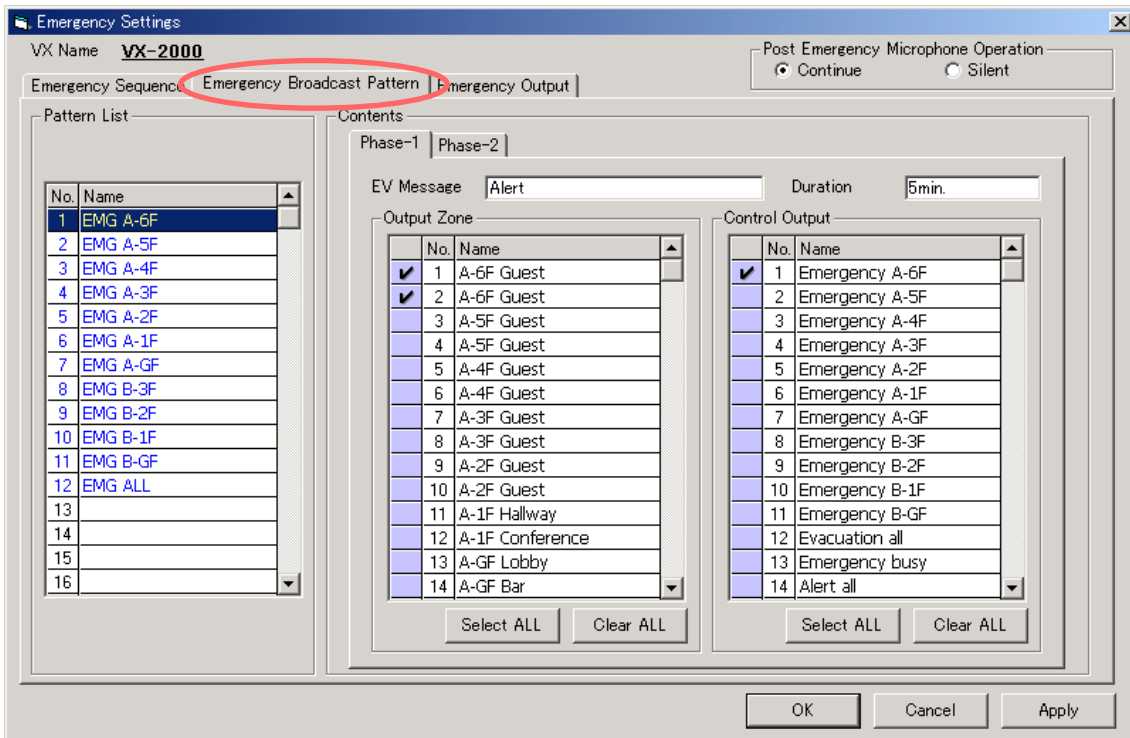

- 3-1. Select the output zone and the control output for the Phase 1 broadcast.
- 3-2. Click on [Phase-2] in the Contents section of the window, and perform the related settings. Pattern names will be displayed in the Pattern List. The pattern names can be easily changed. Select a line to rename, then click on it again, and the name can be changed.

**Step 4.** Click on the [Emergency Output] setting tab.  
Select the control outputs to be used in emergency situations.

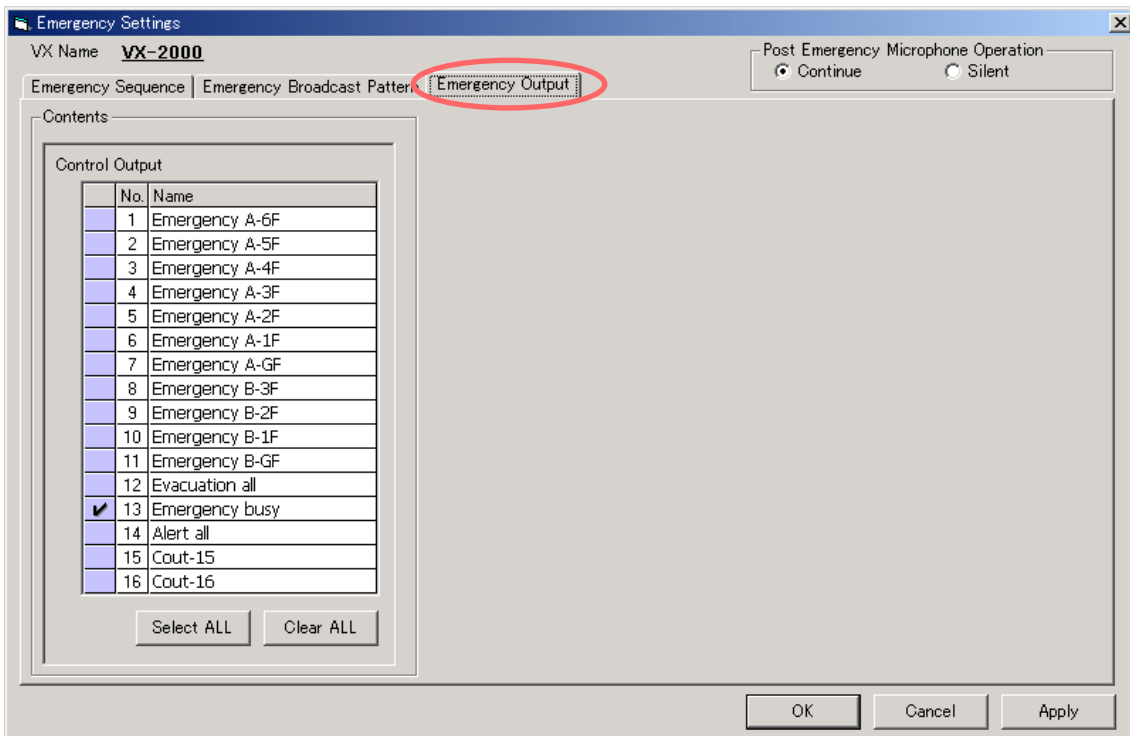

**Step 5.** After setting completion, click on the [Apply] button to save the settings and click on the [OK] button to close the [Emergency Settings] window.

### 9.1.3. When using 2 EV units

The [Emergency Settings] window opens.

Here, up to 50 Alert patterns and 50 Evacuation patterns can be created.

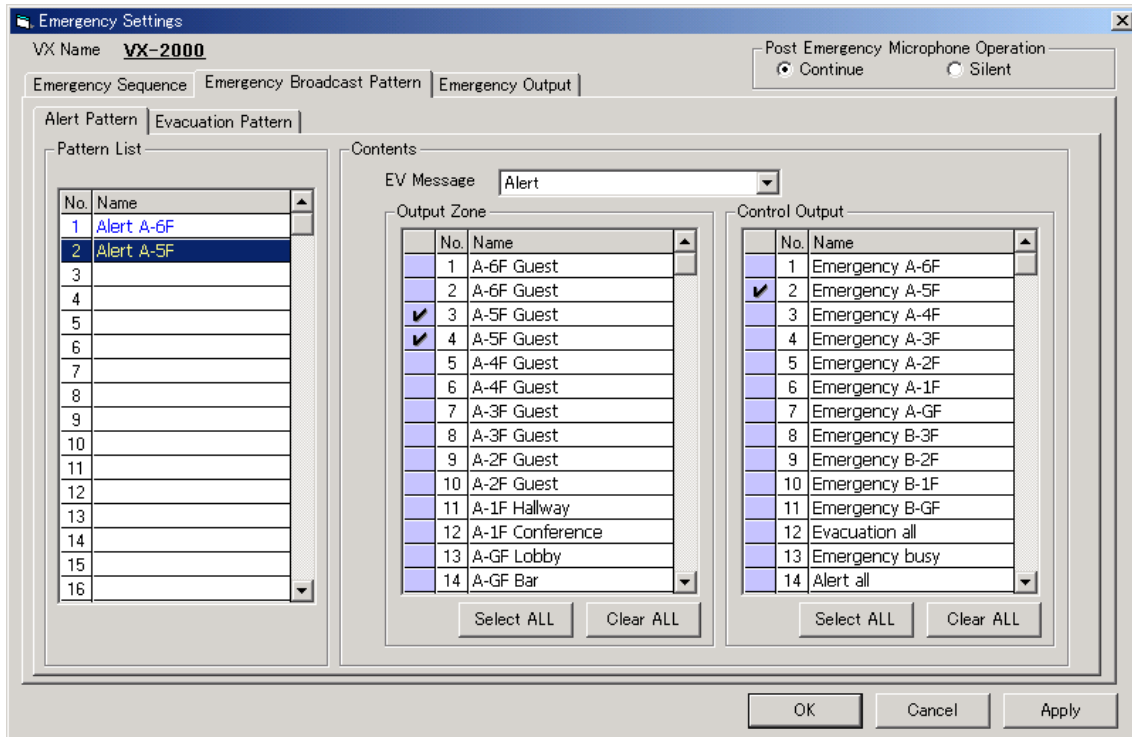

**Step 1.** Set the [Post Emergency Microphone Operation].

- [Continue]: The original EV broadcast to the designated zone(s) is restored after completion of the Fireman's Microphone announcement.
- [Silent]: The original EV broadcast is not restored after completion of the Fireman's Microphone announcement.

**Step 2.** Perform the Emergency Patterns settings. Set the [Alert] pattern(s).

**2-1.** Select "Alert" message for EV Message.

**2-2.** Select the output zone to which the alert message will be broadcast.

Pattern names are displayed in the Pattern List. The pattern names can also be changed. Select a line to rename, then click on it again, and the name can be changed.

**2-3.** Select the control output(s) to be activated during alert message broadcast.

*Continued on next page*

**Step 3.** Set the [Evacuation] pattern(s).

**3-1.** Click on the [Evacuation Pattern] tab.

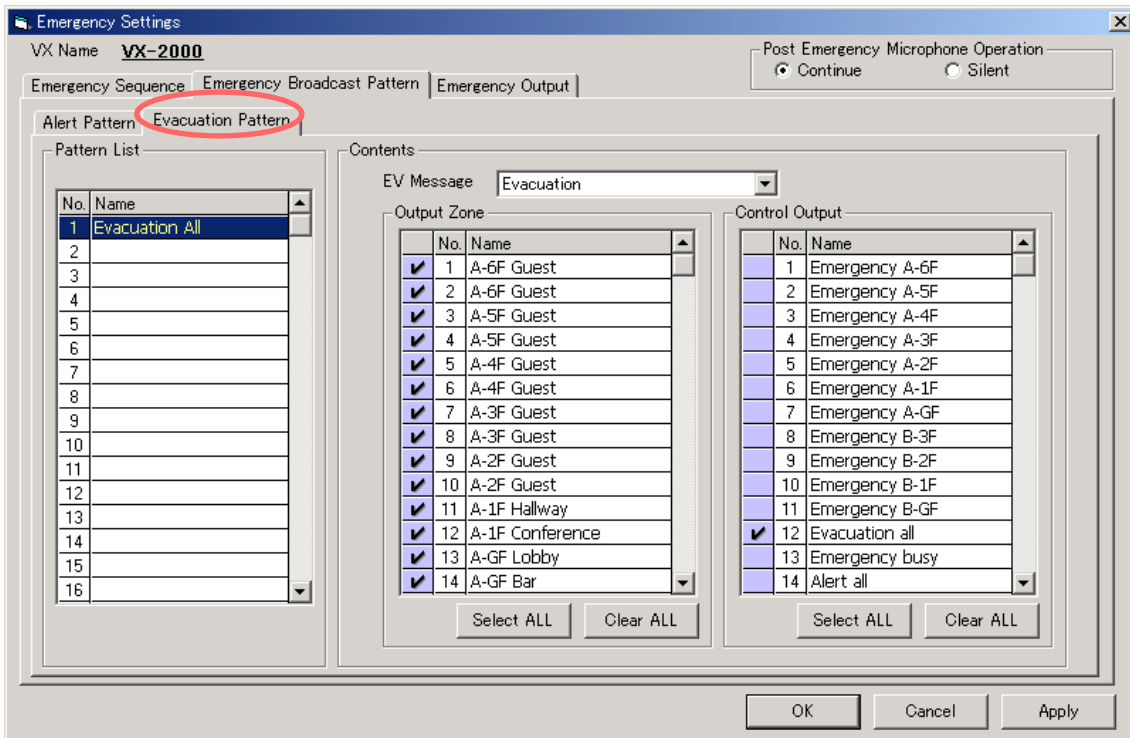

**3-2.** Select "Evacuation" message for EV Message.

**3-3.** Select the output zone(s) to which the evacuation message is to be broadcast.

The pattern name is displayed in the pattern name list. The pattern name can be changed.

**3-4.** Select the control output to be activated during evacuation message broadcast.

*Continued on next page*

**Step 4.** Click on the [Emergency Output] setting tab.

Select the control output(s) to be activated in emergency mode.

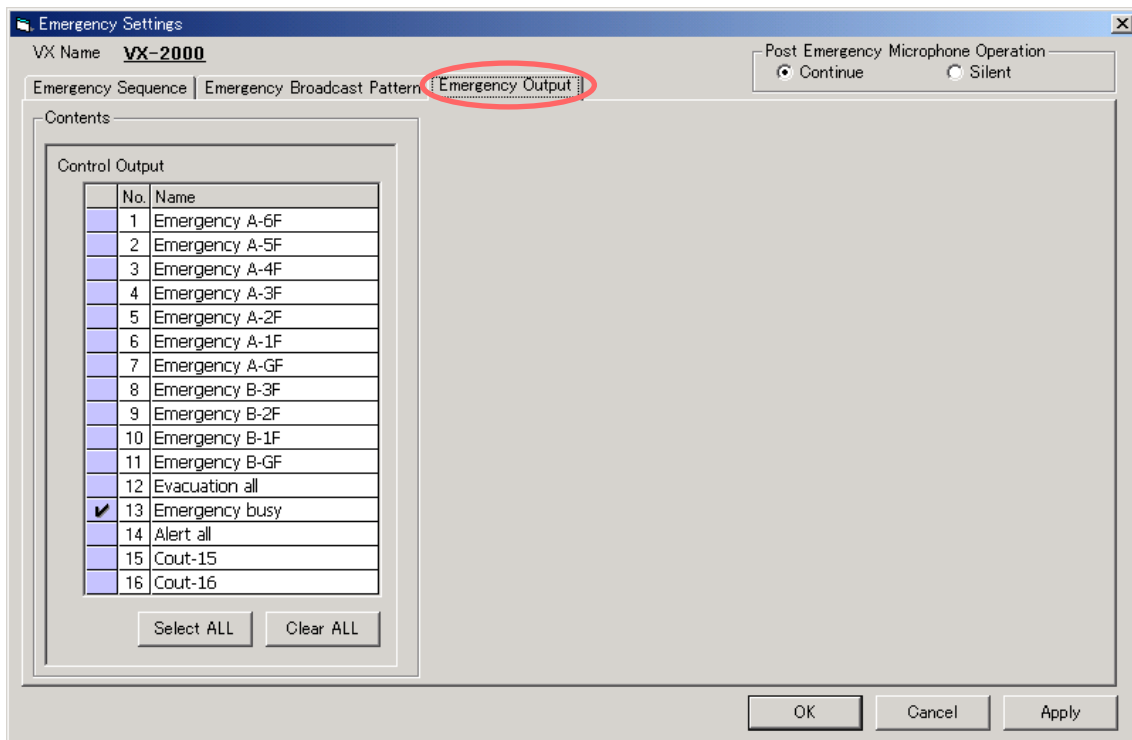

**Step 5.** After setting completion, click on the [Apply] button to save the settings and click on the [OK] button to close the [Emergency Settings] window.

**Note:** Emergency Sequence settings cannot be performed when using 2 EV units.

## 9.2. Pattern Creation

Here, create the patterns for control output, sound volume and individual broadcasts.

The created patterns are assigned to and activated by the Remote Microphone, control input or internal timer. Assign patterns in Activation Setting mode on p. 7-52.

The [Pattern Settings] window can be opened by clicking on the [Pattern] button on the Configuration screen.

### 9.2.1. Control output interlock pattern

Up to 50 control output interlock patterns can be created.

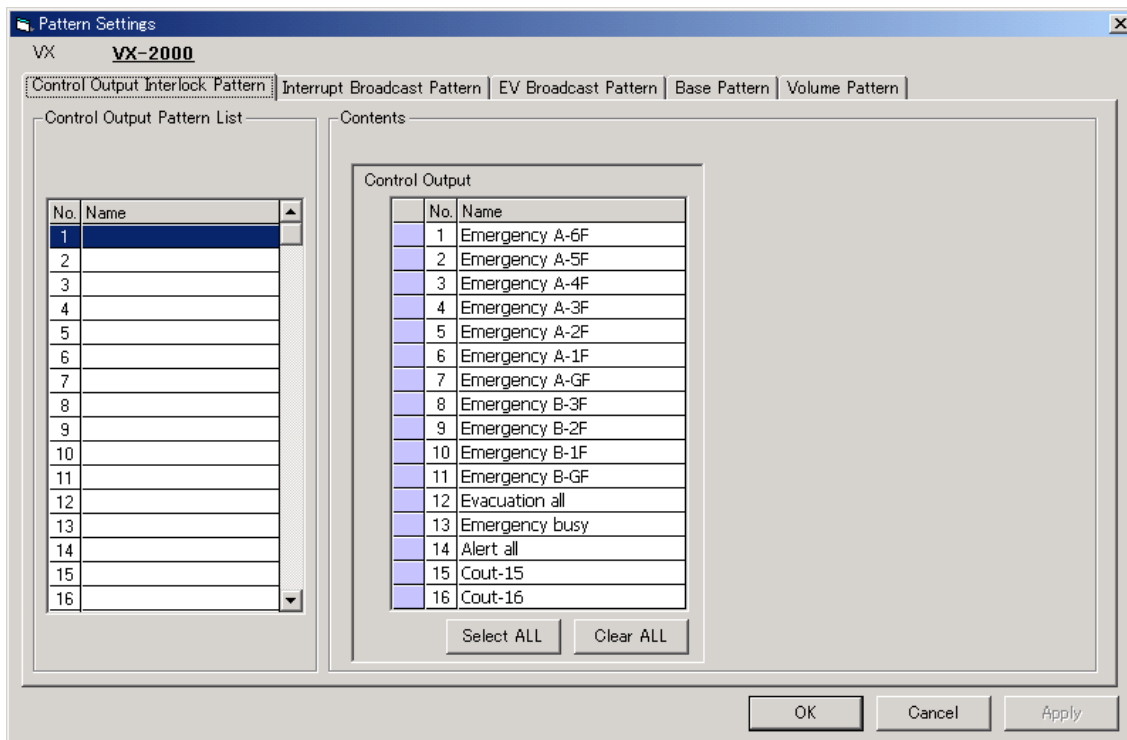

**Step 1.** When the Pattern Settings window opens, the Control Output Interlock Patterns display will appear. Create the control output patterns to be activated by the control input, Remote Microphone or internal timer.

The newly created pattern name is displayed in the Control Output Pattern List. The pattern name can also be changed, if desired. Select a line to rename, then click on it again, and the name can be changed.



## 9.2.2. Interrupt broadcast pattern

Up to 50 interrupt broadcast patterns can be created.

**Step 1.** Click the [Interrupt Broadcast Pattern] tab.

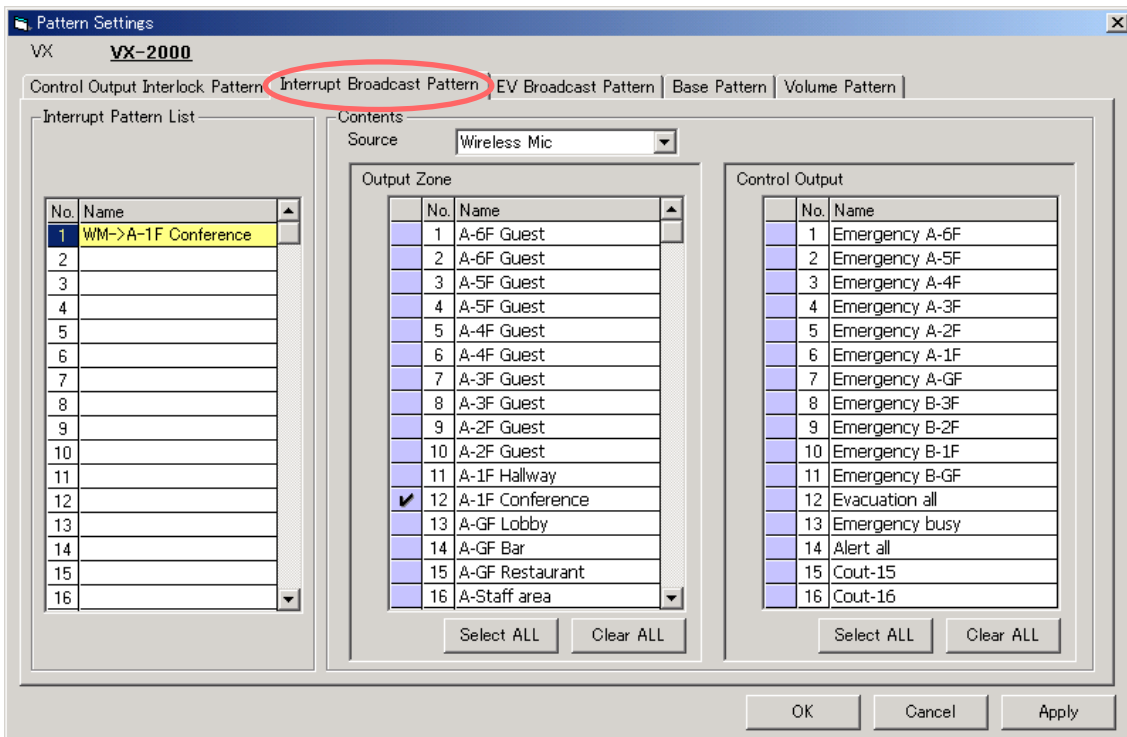

**Step 2.** Set the sound source, output zone and control output combination to be activated as interrupt broadcasts by control input or internal timer.

**2-1.** Select the sound source.

VX-2000's input sources are displayed in the sound source menu. (The Remote Microphone, however, is not listed in the source pull-down menu because the Remote Microphone broadcast can be made by selecting zones, requiring no pattern settings.)

**2-2.** Select the output zone.

The pattern name will be displayed in the Interrupt Pattern List. The pattern name can also be changed, if desired. Select a line to rename, then click on it again, and the name can be changed.

**2-3.** Select the control output.

Select the control output to be activated during interrupt broadcast.

### 9.2.3. EV broadcast pattern

Up to 20 EV broadcast patterns can be created.

**Step 1.** Click on the [EV Broadcast Pattern] tab.

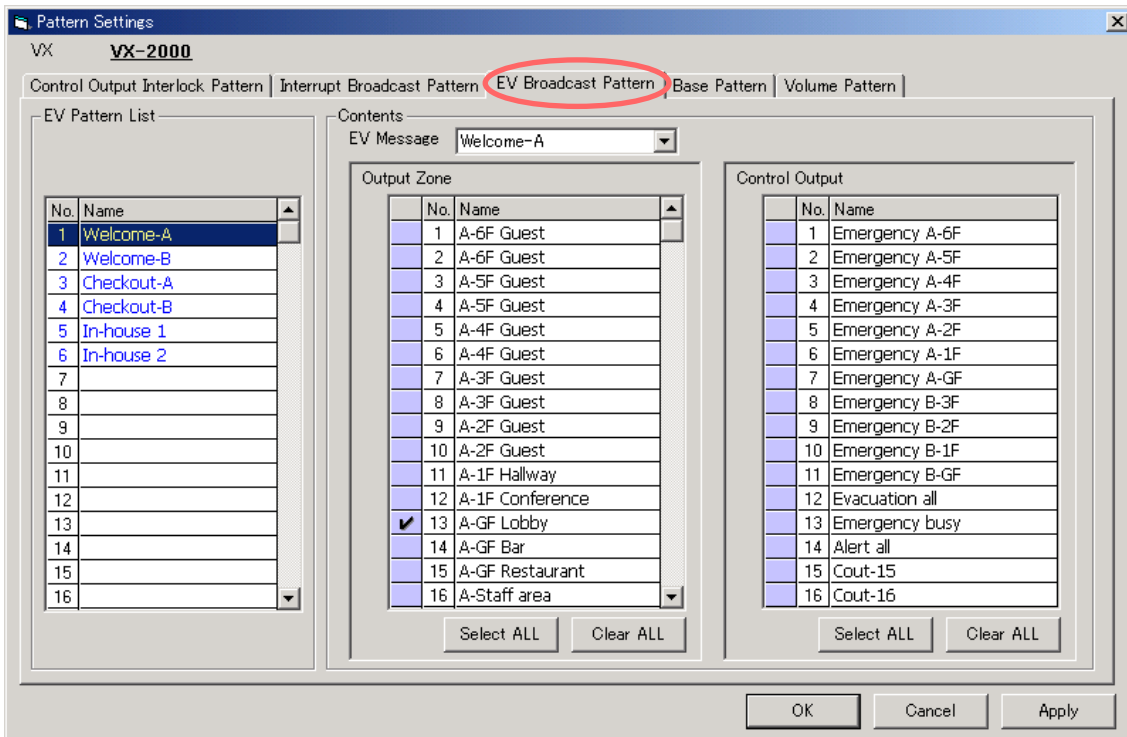

**Step 2.** Set the EV message, output zone and control output combination to be activated by control input or internal timer.

**2-1.** Select the EV message.

The general-purpose message programmed into the EV unit will be displayed.

**2-2.** Select the output zone.

The pattern name will be displayed in the EV Pattern List. The pattern name can also be changed, if desired. Select a line to rename, then click on it again, and the name can be changed.

**2-3.** Select the control output.

Select the control output to be activated during EV message broadcast.

### 9.2.4. Base pattern

Up to 20 base patterns can be created.

**Step 1.** Click on the [Base Pattern] tab.

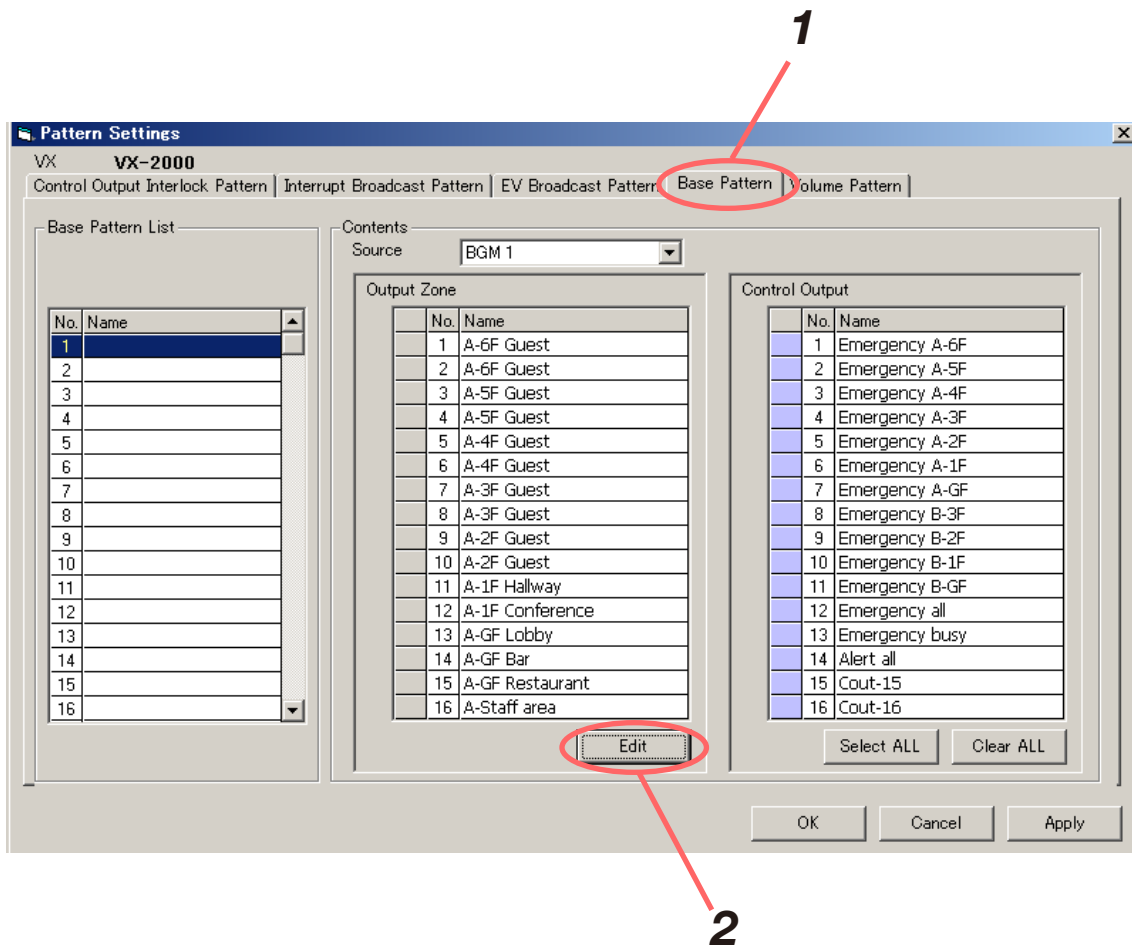

*Continued on next page*

**Step 2.** Click on the [Edit] button.

The [Base Pattern Settings] window will open.

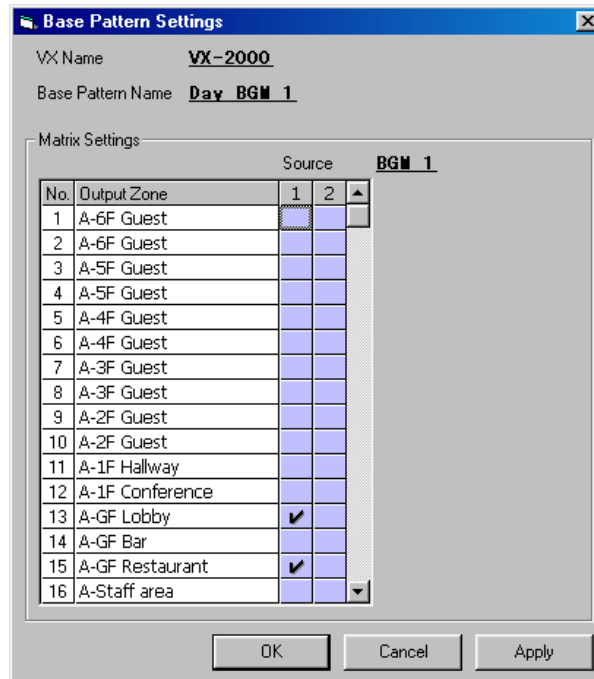

**Step 3.** Set the combination of sound source (set as BGM) and output zone(s) to be activated by the control input, Remote Microphone or internal timer.

**3-1.** Set the output zone for each sound source.

**3-2.** Click on the [Apply] button to save the settings and click on the [OK] button to close the [Base Pattern Settings] window.

The pattern name is displayed in the Base Pattern List. The pattern name can also be changed, if desired. Select a line to rename, then click on it again, and the name can be changed.

The output zone(s) assigned to each sound source can be viewed in the Contents column. Changing the sound source will also change the output zone display.

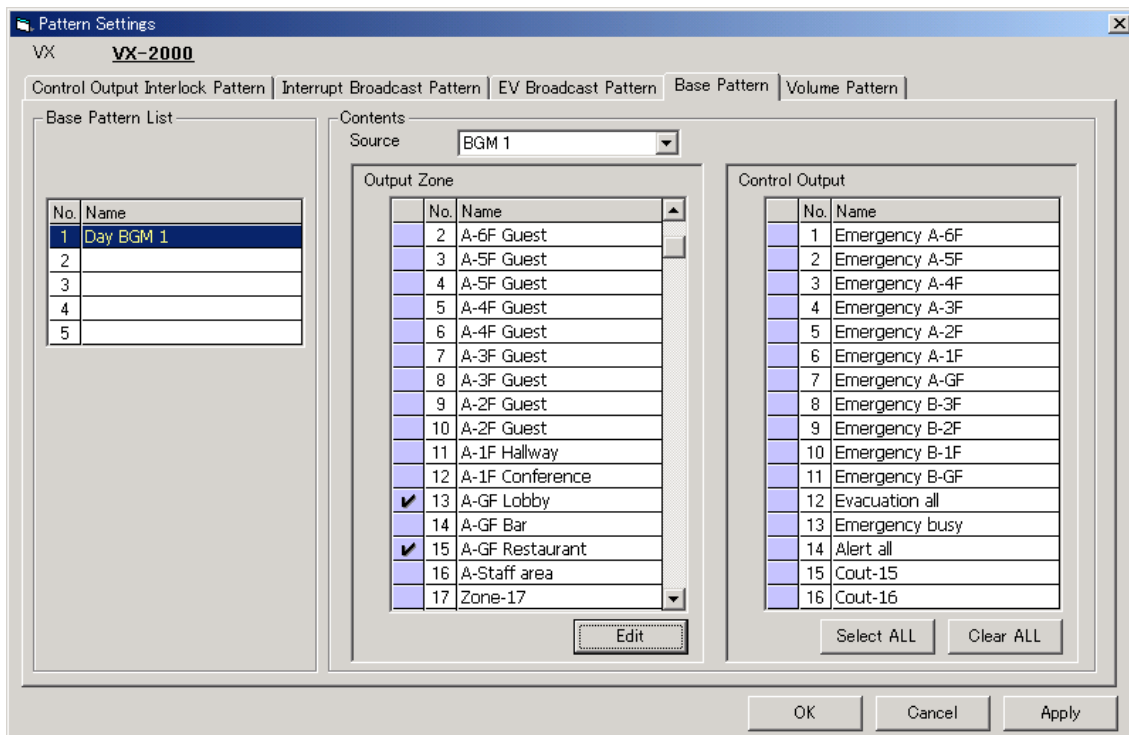

**3-3.** Select the control outputs to be activated during base pattern broadcast.

### 9.2.5. Volume pattern

Up to 156 volume patterns can be created.

**Step 1.** Click on the [Volume Pattern] tab.

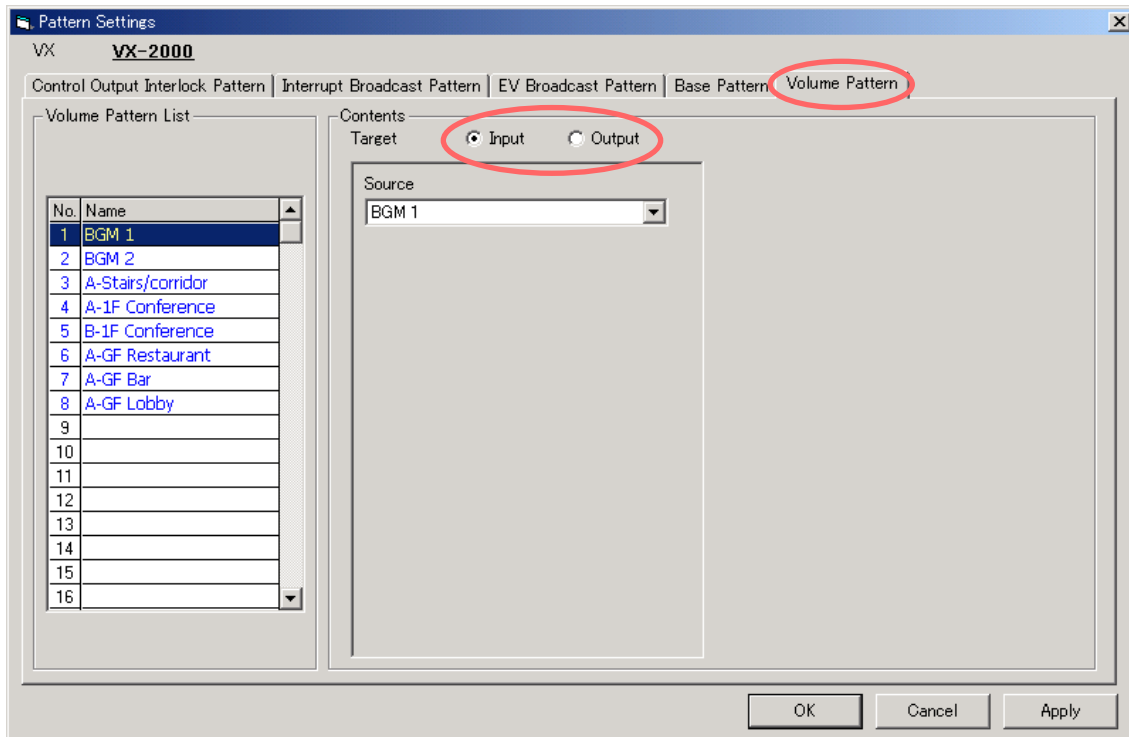

**Step 2.** Select the target for the volume pattern.

Select either "Output" or "Input" volume for the targeted volume pattern.

#### [When operating the input volume]

2-1. Select [Input].

2-2. Select the sound source for the volume which needs to be changed, if desired.

The pattern name is displayed in the Volume Pattern List. The pattern name can be changed. Select a line to rename, then click on it again, and the name can be changed.

#### [When operating the output volume]

2-1. Select [Output].

2-2. Select the output zone of which volume needs to be changed.

The pattern name is displayed in the Volume Pattern List. The pattern name can also be changed, if desired. Select a line to rename, then click on it again, and the name can be changed.

**Step 3.** After completing all settings, click on the [Apply] button to save the settings and click on the [OK] button to close the [Pattern Settings] window.

### 9.3. Failure Output Pattern Creation

Up to 315 patterns can be created.

Clicking the [Failure Output] button on the Configuration screen will display the [Failure Output Pattern Settings] window.

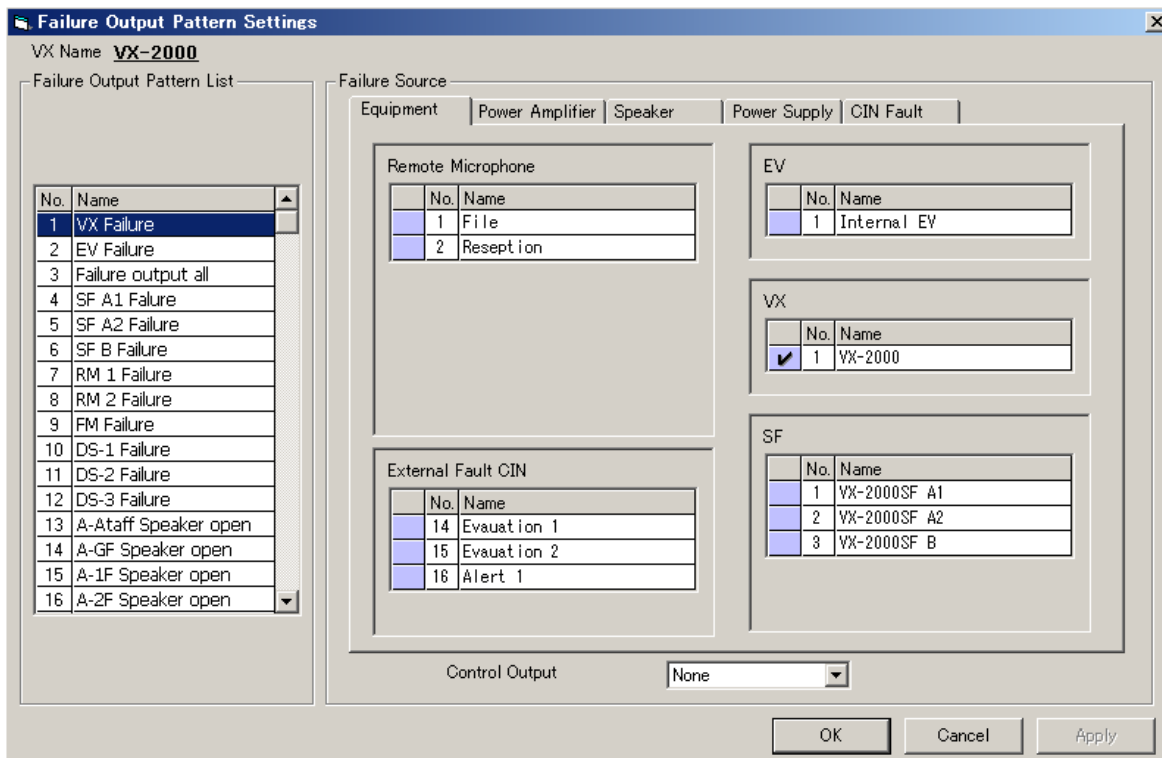

**Step 1.** Determine the [Failure Sources].

From the right-side setting contents screen, select the failure sources to be monitored by clicking the Equipment, Power Amplifiers, Speakers, and Power Supplies tabs respectively.

If even one Failure source is selected, the pattern name will be displayed in the Failure Output Pattern List. The failure output pattern name can be changed, if desired. Select a line to rename, then click on it again, and the name can be changed.

**Step 2.** Select the interlock control output.

Select the control output from the [Control Output] menu.

**Step 3.** After setting completion, click on the [Apply] button to save the settings and click on the [OK] button to close the [Failure Output Pattern Settings] window.

## 10. ACTIVATION SETTING MODE

Select [Edit → Activation Setting Mode] from the menu.

Clicking on the  button in the toolbar also enables the activation setting mode.

Here, functions can be assigned to the Remote Microphone function keys, and the control input and internal timer set.

VX-2000		
VX-200 XR	Monitor	Control Output
VX-200 XR	EV	
VX-200 XR	Priority	Initial Volume
VX-200 XI	EQ	
U-01R	Emergency	
U-01R	Pattern	
U-01R	Failure Output	
Slot-8	Control Input	Timer

### 10.1. Remote Microphone Function Key Assignment

Remote Microphone function keys can be assigned various functions other than simply recalling patterns created in the Emergency Broadcast, Pattern, and Failure Output Pattern Settings.

**Step 1.** Click the right mouse button over the corresponding Remote Microphone icon, and the following pop-up menu will be displayed.

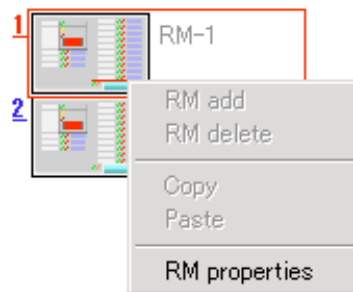

*Continued on next page*

**Step 2.** Select "RM Properties" and the [RM Properties] key setting screen will open.

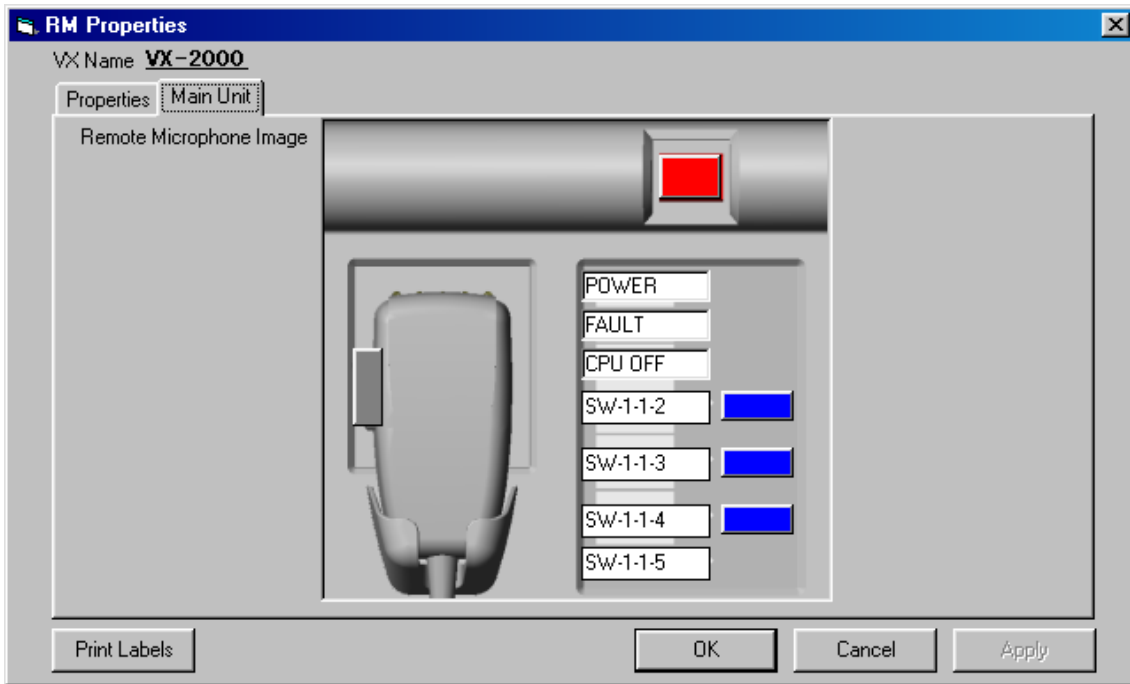

**Step 3.** Click on one of the function keys in the displayed remote control unit illustration. The Remote Microphone's [Function Key Settings] window will open.

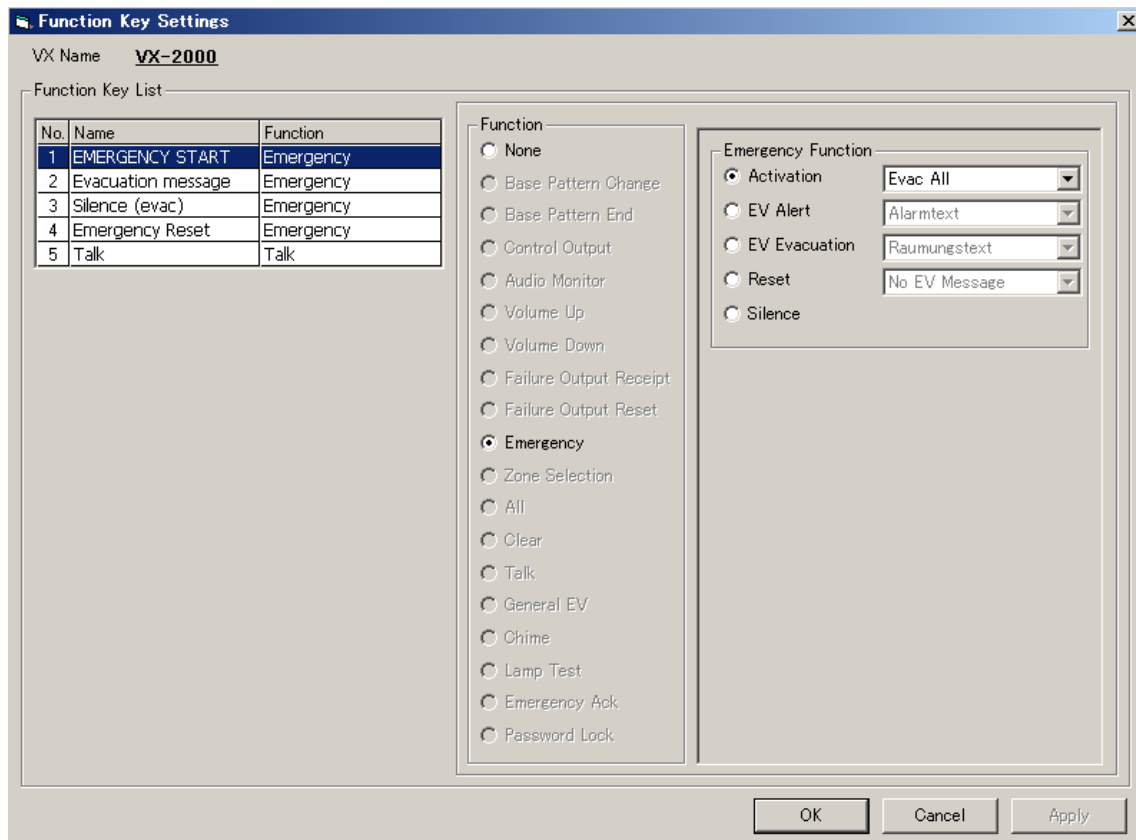

*Continued on next page*



**Step 4.** Select the key to which a function is to be assigned.

The function key name can also be changed. Select a line to rename, then click on it again, and the name can be changed.

**Step 5.** Select the function.**[Description of assignable functions]**

None	No function is set for the key.
Base Pattern Change	Makes broadcasts with the base pattern set in the [Pattern Settings].
Base Pattern End	Stops only base pattern broadcasts.
Control Output Interlock	Activates the control output set in the [Pattern Settings].
Audio Monitor	Selects a single zone to be monitored with the Remote Microphone's monitor speaker.
Volume Up/Down	Change the sound volume for the volume pattern set in the [Pattern Settings]. The volume level changes by 3 dB each time the key is pressed.
Failure Output Receipt	Pressing the key after confirming the failure symptoms stops a buzzer and changes the failure indicator light to steady-on. (When a failure corresponding to the pattern created in the [Failure Output Pattern Settings] occurs, the failure indicator flashes, and a buzzer is sounded.)
Failure Output Reset	Clears the failure status and exits the failure indication mode. (Extinguishing the failure indicator lamp and stopping the buzzer.)
Emergency	<p><b>[When "General" type is set for the Remote Microphone]</b> (For general-purpose broadcasts only)</p> <p>Only functions that are related to emergency activation can be set. Enters emergency mode. The patterns set in [Emergency Settings] can also be recalled and broadcast.</p> <p><b>[When "Emergency" type is set for the Remote Microphone]</b> (For both emergency and general-purpose broadcasts)</p> <ul style="list-style-type: none"> <li>• Emergency Activation: Enters emergency mode. Patterns set in the [Emergency Settings] window can also be recalled and broadcast.</li> <li>• Emergency Alert: Recalls the alert message.</li> <li>• Emergency Evacuation: Recalls the evacuation message.</li> <li>• Emergency Reset: Restores the emergency mode to normal mode. The reset message can also be recalled.</li> <li>• Silence: The EV message stops.</li> </ul>
Zone Selection	Broadcasts are pre-selected for zones selected here.
All	Broadcasts are pre-selected for all zones.
Clear	Cancel pre-selections.
Talk	<p>Press when making announcements from the microphone.</p> <p><b>Notes</b></p> <ul style="list-style-type: none"> <li>• The operation of the Talk key can be set to either of the following 2 types: <ul style="list-style-type: none"> <li>PTT: Broadcasts can be made as long as the switch is pressed.</li> <li>Lock: Pressing the switch turns on the microphone and permits broadcasts. The microphone turns off when the switch is pressed again. The timer can be set for 1 – 20 minutes in 1-minute step to automatically turn off the microphone if the user forgets to turn it off. The timer function can be disabled by selecting "Infinity".</li> </ul> </li> <li>• Pre-announcement chime and post-announcement chime can also be enabled or disabled with these settings.</li> </ul>
General EV	Accesses the general-purpose EV messages.
Chime	The internal chime can be assigned to specific messages and broadcasts.

Lamp Test*	Executes the Lamp Test. The Remote Microphone's buzzer continues to sound and each FAULT indicator on the VX-2000's and VX-2000SF's front panel lights during test. The original condition is automatically restored when the test is completed.
Emergency Ack.*	Assigning this function to a Function key allows the buzzer to sound at the time of emergency broadcast. Use this function to stop the buzzer.
Password Lock*	Permits the password-locked Remote Microphone to operate by entering a password. Operation timeout period after password entry can be selected at the time of function assignment to the key. Only the Lamp test key operation and Failure Output Receipt key operation are possible while in the Password entry status.

\* Available only when the VX-2000 Setting Software Version 2.1 or later is installed.

**Step 6.** After setting completion, click on the [Apply] button to save the settings and click on the [OK] button to close the [Function Key Settings] window.

**Step 7.** When setting up a Remote Microphone Extension unit RM-210, click the appropriate [Extension Unit] tab.

Repeat Steps 3 – 6 above to assign functions to the unit's function keys.

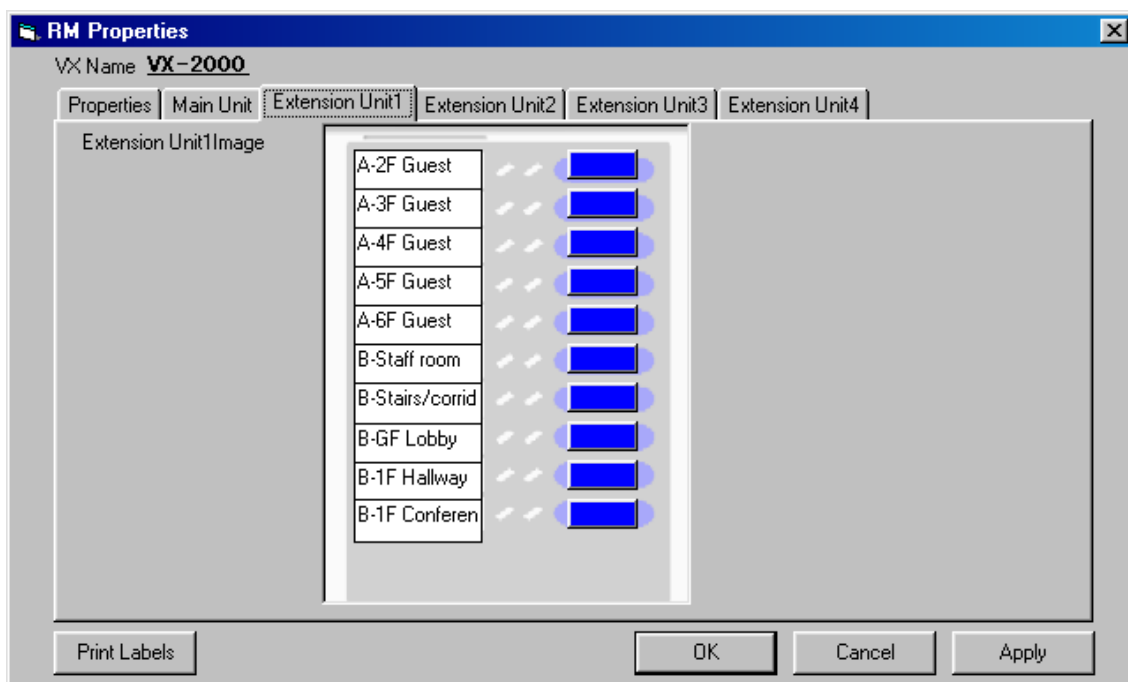

### Tips

- Clicking on [Print Labels] on the RM Properties screen permits the set function key names to be printed out. The printed names can then be used as labels for the corresponding Remote Microphone or Extension Unit.
- The printed name can be formatted in 2 or 3 lines on the label by entering double slash "/" at a linefeed position in the function key name column on the screen.

## 10.2. Control Input Settings

Clicking the [Control Input] button on the Configuration screen opens the [Control Input Settings] window. The control inputs can be assigned various functions other than the patterns created in the Emergency, Pattern, and Failure Output Pattern Settings.

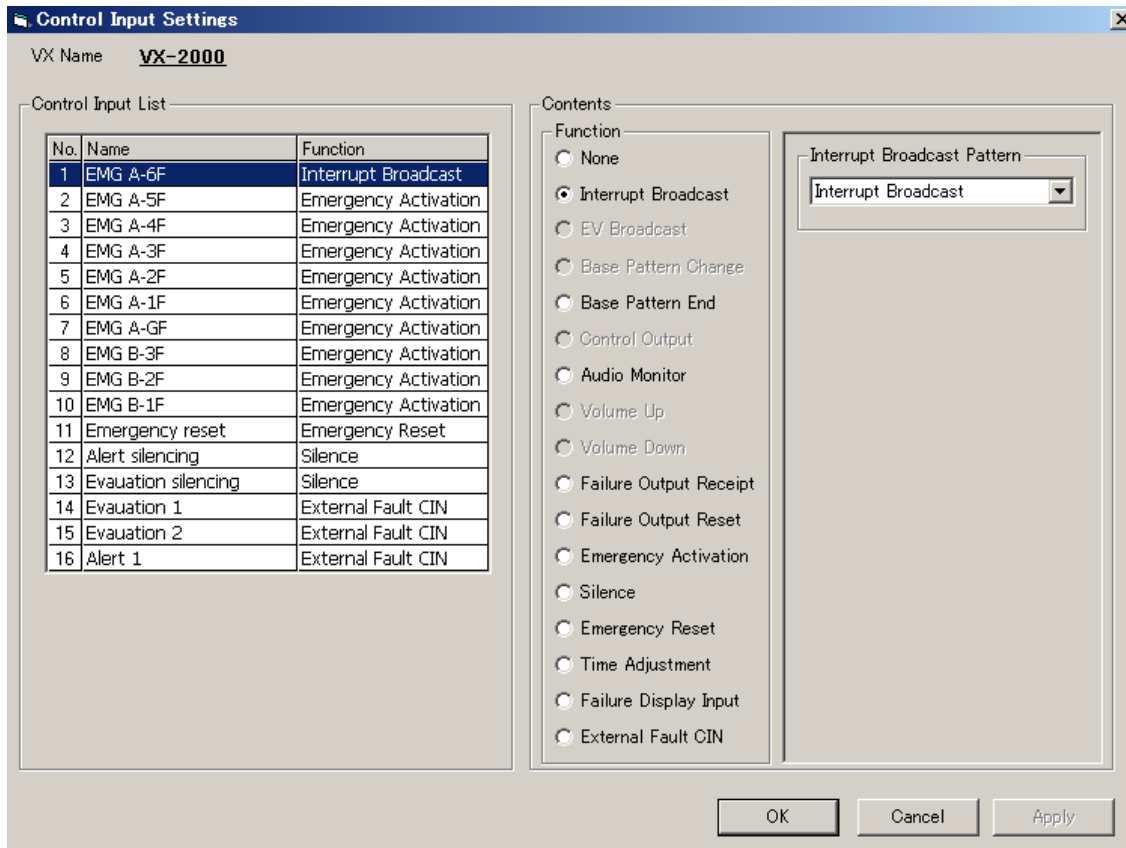

**Step 1.** Select the control input to which a function is to be assigned from the Control Input List. The name of the control input can also be changed. Select a line to rename, then click on it again, and the name can be changed.

*Continued on next page*

**Step 2.** From the setting Contents, select the control input's assigned function.

**[Description of assignable functions]**

None	No function set for the control input.
Interrupt Broadcast	Makes broadcasts according to the interrupt broadcast pattern set in the [Pattern Settings] window.
EV Broadcast	Makes broadcasts according to the EV broadcast pattern set in the [Pattern Settings] window.
Base Pattern Change	Makes broadcasts according to the base pattern set in the [Pattern Settings] window.
Base Pattern Stop	Stops only base pattern broadcasts.
Control Output Interlock	Activates the control output set in the [Pattern Settings] window.
Audio Monitor	Selects one zone to be monitored.
Volume Up/Down	Changes the output volume relative to the volume pattern set in the [Pattern Settings] window. Changes can be made in steps of 3, 6, 9, 12, 15, 18 or 21 dB.
Failure Output Receipt	If a failure is confirmed and a control input is activated, a Remote Microphone's buzzer stops and the failure indicator changes from flashing to continuously lit. A control output can be provided in synchronisation with the control input activation. (When a failure corresponding to the pattern created in the [Failure Output Pattern Settings] window takes place, Remote Microphone's the failure indicator flashes and the buzzer sounds.)
Failure Output Reset	Clears the failure mode and exits the failure indication mode. (Extinguishing all failure indicators and stopping the buzzer.)
Emergency Activation	Enters emergency mode. It is also possible to recall and broadcast the pattern set in the [Emergency Pattern Settings] window.
Silence	The EV message stops.
Emergency Reset	Resets the emergency mode to general mode.
Time Adjustment	Corrects the VX-2000's time to the nearest $\pm 30$ seconds. (Example) If a control input is received at 00:05:45, the time is adjusted to 00:06:00. If a control input enters at 00:05:15, the time is adjusted to 00:05:00.
Fault Display Input	Receives failure input data from other system components and enables the failure indicators of the RM-200XF, RM-200X, VX-2000 and VX-2000SF units.
External Fault CIN*	Assigns the failure data from the external equipment to the Failure Output Pattern.

\* Available when the VX-2000 Setting Software Version 2.1 or later is installed.

**Step 3.** After setting completion, click on the [Apply] button to save the settings and click on the [OK] button to close the [Control Input Settings] window.

## 10.3. Timer Settings

Clicking on the [Timer] button on the Configuration screen opens the [Timer Settings] window.

### 10.3.1. Day programs

Up to 10 day programs can be created.

**Step 1.** Set both the start and end times in the "Contents" section of the window.

Move the mouse over a blue vertical bar causes the " $\leftrightarrow$ " indicator to appear. Time settings can be performed by "grabbing" (holding the left mouse button down) the bar with " $\leftrightarrow$ " mark displayed, and pulling it to the left or right. Start and end times can also be set by directly entering the numerical value.

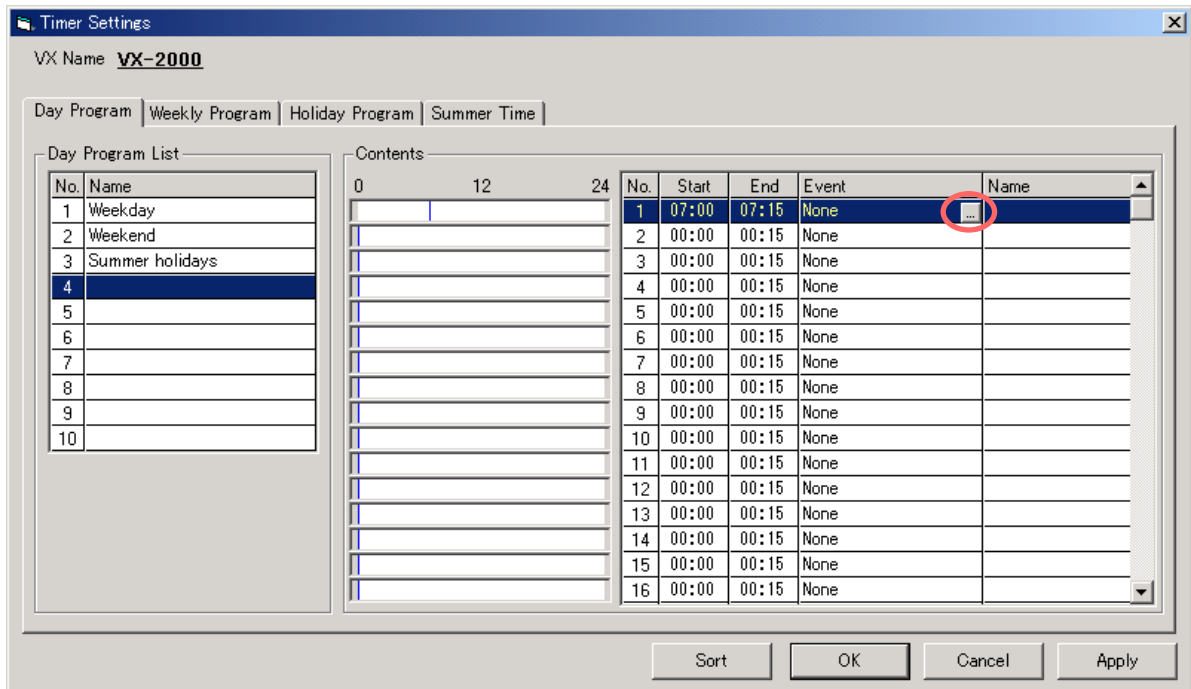

**Step 2.** Set the event.

If the  button to the right of [None] is clicked, the [Event Settings] window will open.

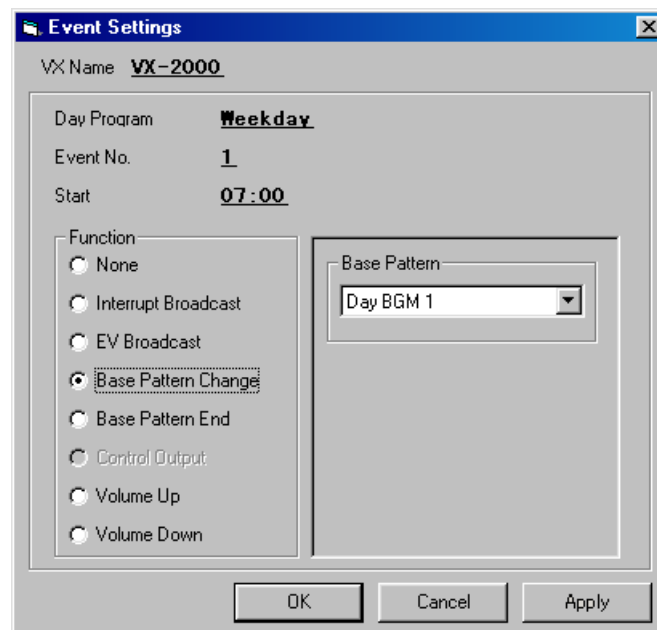

*Continued on next page*

The following functions can be set:

None	Nothing set.
Interrupt Broadcast	Makes broadcasts according to the interrupt broadcast pattern set in the [Pattern Settings] window.
EV Broadcast	Makes broadcasts according to the EV broadcast pattern set in the [Pattern Settings] window.
Base Pattern Change	Makes broadcasts according to the base pattern set in the [Pattern Settings] window.
Base Pattern End	Stops only base pattern broadcasts.
Control Output	Activates the control output set in the [Pattern Settings] window.
Volume Up/Down	Change the output volume of the broadcasts based on the volume pattern set in the [Pattern Settings] window. The volume can be changed in steps of 3, 6, 9, 12, 15, 18 or 21 dB.

**Step 3.** After the event setting is completed, click on the [Apply] button to save the settings and click on the [OK] button to close the [Event Settings] window.

Event and pattern names set in the [Timer Settings] window will be displayed, and program names displayed in the Day Program List.

The program names can also be changed. Select a line to rename, then click on it again, and the name can be changed.

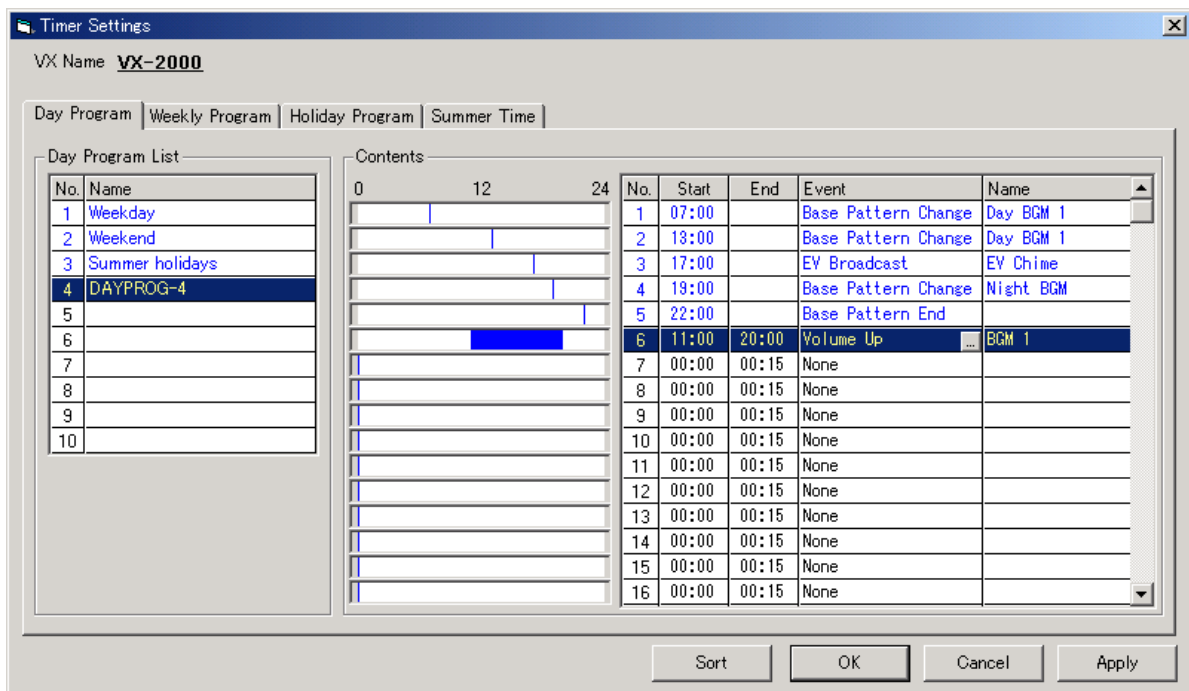

**Tip:** Clicking on the [Sort] button sorts the events set for the Day program in chronological order.

### 10.3.2. Weekly program

Broadcast programs for an entire week can be created by assigning the day-based programs created in the day program to each day of the week.

**Step 1.** Click on the [Weekly Program] tab.

**Step 2.** Assign the broadcast settings created in the day program to each corresponding day of the week.

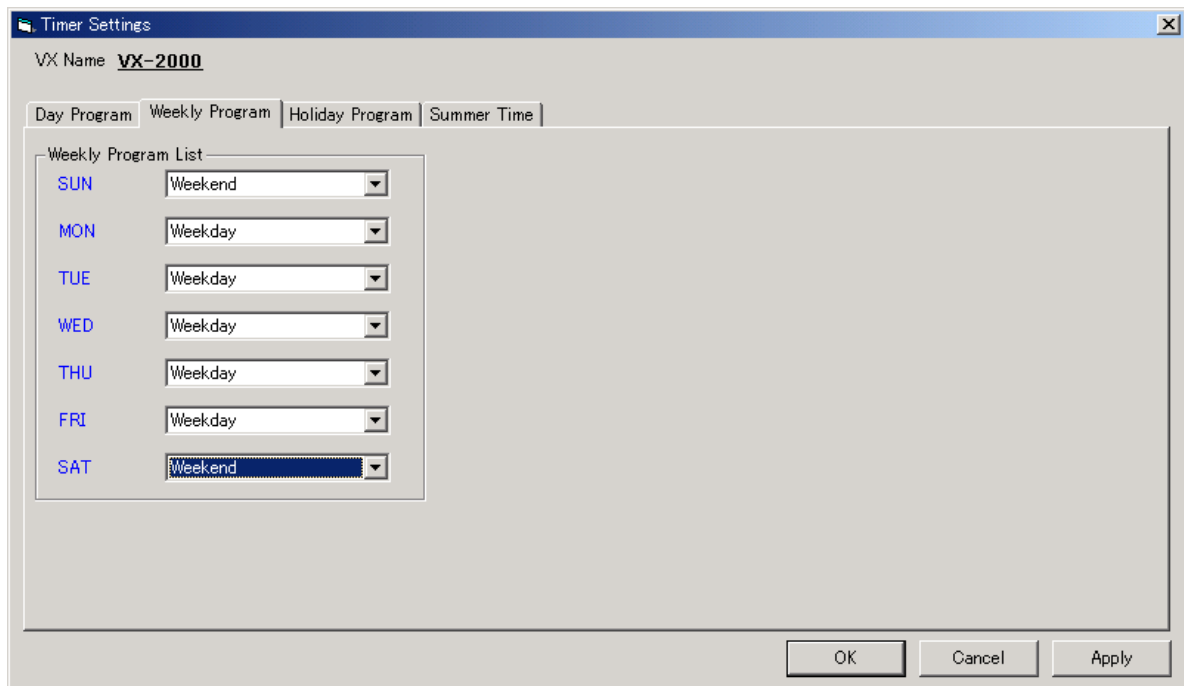

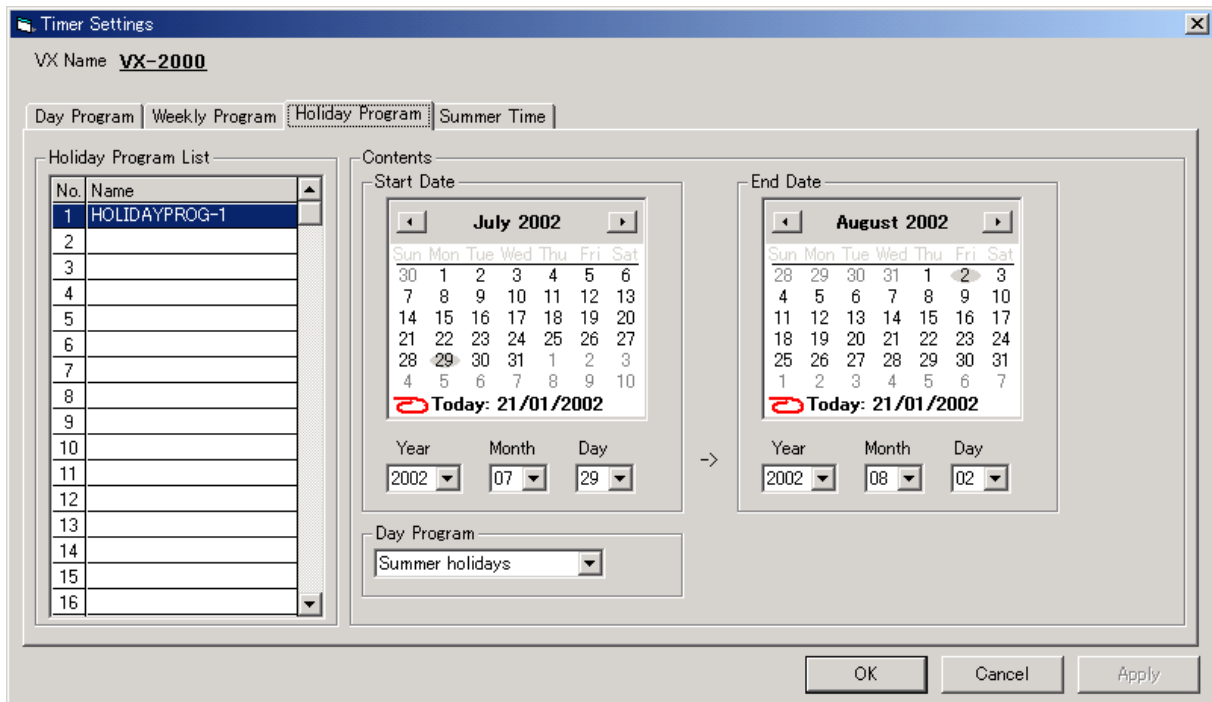

### 10.3.3. Holiday programs

Day programs to be broadcast only during limited periods of time –such as holidays– can also be set. Up to 40 holiday programs can be created.



**Step 1.** Click on the [Holiday Program] tab.

**Step 2.** Set the start date.

- Use the  and  arrow buttons located in the upper corners of the calendar window to display and set the start date's month and year.
- Click on the start date.

**Step 3.** Set the end date in the same way.

**Step 4.** From the day program, select the broadcast settings to be used during the holiday period.

Program names will be displayed in the [Holiday Program] list, and can be changed as desired. Select a line to rename, then click on it again, and the name can be changed.



### 10.3.4. Summer time

The clock advances by an hour during the summer time period. The summer time period can be set using PC software or the VX-2000's DAYLIGHT SAVING switch settings.

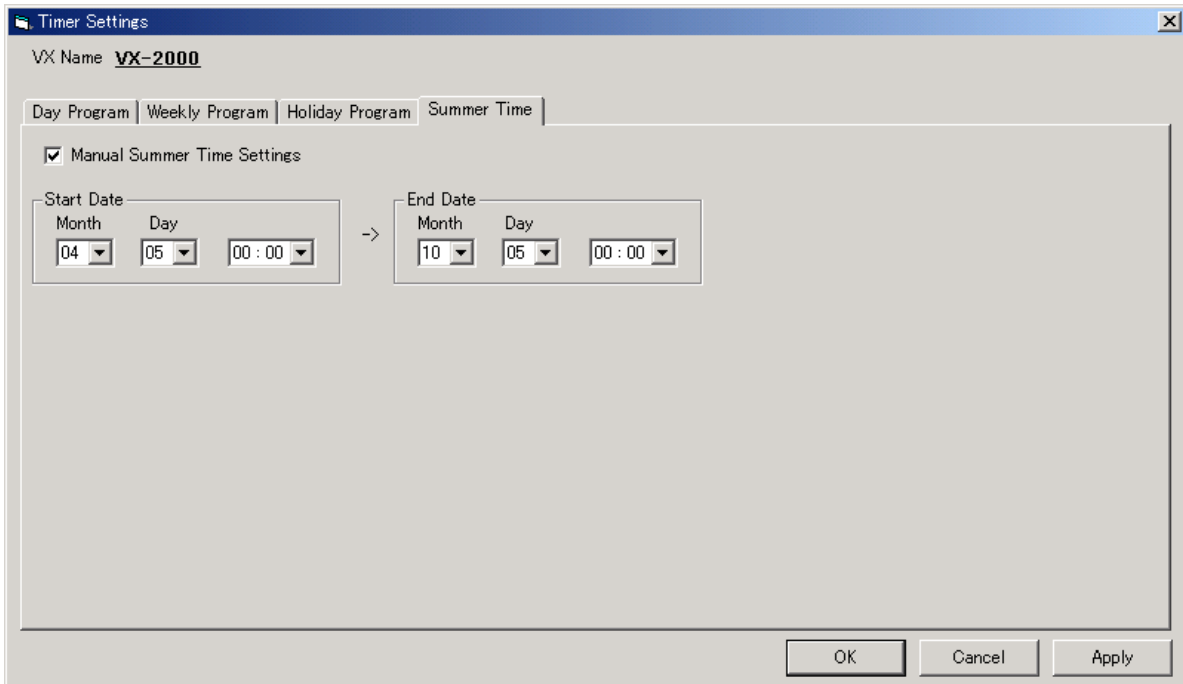

**Step 1.** Click on the [Summer Time] tab.

**Step 2.** Tick the checkbox for [Manual Summer Time Settings].

**Step 3.** Set the start date and time.

- Click on the  arrow button to the right of the month reading to set the summer time start month.
- Set the start date.
- Set the start time.

**Step 4.** Set the end date and time using the same procedure.

**Step 5.** After all settings are complete, click on the [Apply] button to save the settings and click on the [OK] button to close the [Timer Settings] window.

## 11. PRINTING OUT SETTING DATA

**Step 1.** Select [File → Print] from the menu.

The [Printout] window will open.

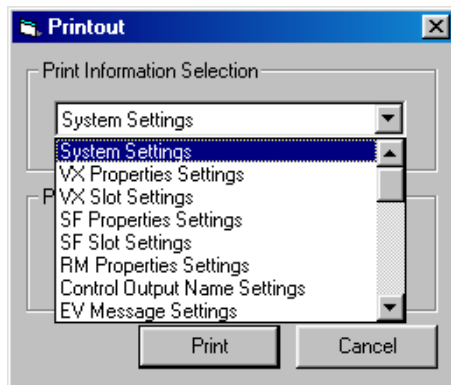

**Step 2.** Select the item to be printed in the [Print Information Selection] menu.

The available printout items are as follows:

Item	Printout Contents
System Settings	General system information
VX Properties Settings	VX properties
VX Slot Settings	Usable input module list
SF Properties Settings	SF properties
SF Slot Settings	Usable SF module list
RM Properties Settings	RM properties list
Control Output Name Settings	Control output name list
EV Message Settings	EV message list
Priority Settings	Priority setting list
Initial Source Volume Settings	Initial source volume list
Initial Output Volume Settings	Initial output volume list
EQ Settings	Individual equaliser setting list
Emergency Sequence Settings* <sup>1</sup>	Emergency sequence settings
Alert Broadcast Pattern Settings* <sup>2</sup>	Alert broadcast pattern routings
Evacuation Broadcast Pattern Settings* <sup>2</sup>	Evacuation broadcast pattern routings
Emergency Broadcast Pattern Settings	Emergency broadcast pattern list
Emergency Output Pattern Settings	Emergency control output name list
Control Output Pattern Settings	Control output interlock pattern list
Interrupt Broadcast Pattern Settings	Interrupt broadcast pattern list
EV Broadcast Pattern Settings	EV broadcast pattern list
Base Pattern Settings	Base pattern routings
Volume Pattern Settings	Volume pattern list
Failure Output Pattern Settings	Failure output settings pattern list
RM Function Key Setting	Functions assigned to each RM function key
Control Input Settings	Control input
Day Program Settings	Time and activation pattern
Weekly Program Settings	Day of the week and day programs to be activated
Holiday Program Settings	Period and day programs to be activated
Log List	VX log file
System Configuration	All equipment used within the system and their connections
RM Function Key Labels	RM function key name labels used for RM-200XF/200X/210

\*<sup>1</sup> Displayed when 1 EV unit is used.

\*<sup>2</sup> Displayed when 2 EV units are used.

**Step 3.** Press the [Print] button to print.

# ***Chapter 8***

---

## ***INSTALLATION AND SETTING PROCEDURES (HARDWARE)***

## WARNING

Some settings require equipment panels to be removed. Make sure that the system's power is switched OFF when there is a chance of bodily contact with the internal components of the equipment, or when removing or inserting modules. For procedures regarding switching off the system power, refer to the Instruction Manual attached to the VX-2000DS/3000DS.

## 1. RM-200XF AND RM-200X MICROPHONES

### 1.1. DIP Switch Settings

#### 1.1.1. DIP switch functions

[RM-200XF Bottom]

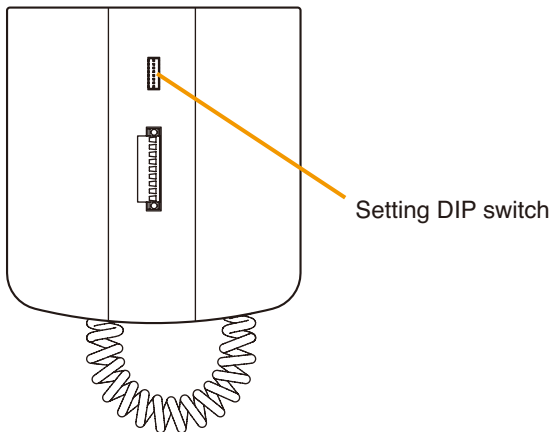

[RM-200X Side]

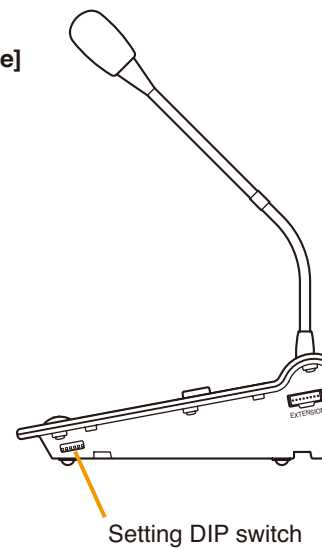

#### [Functions common to both the RM-200X and the RM-200XF]

Switch No.	1	2	3	4	5	6
Function	Unit ID No. Setting				Level Meter Mode ON/OFF	Compression ON/OFF

#### [Functions available only to the RM-200XF]

Switch No.	7	8
Function	Emergency Button Enable/Disable	Function Key 2 Enable/Disable

**1.1.2. Unit ID number settings (Switches 1 – 4)**

- A total of up to 8 RM-200X and RM-200XF microphones can be connected per system. However, connections to individual units are limited to the following:

Designated for Emergency use: Up to 4 units in a total of the RM-200XFs and RM-200Xs

Designated for General use: Up to 8 units of RM-200Xs only

- A Unit ID Number must be set for each connected Remote microphone. The Unit ID Number must be identical to that which is set by the PC software. On the PC screen, the ID Number appears at the top left of the Remote microphone symbol.

**[Remote microphone on the PC screen]**

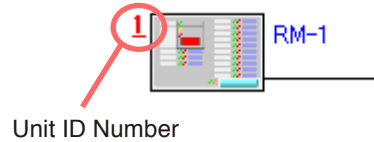

- The ID Number is factory-preset to "1."

**[Unit ID Number settings]**

Switch No. / Unit ID Number	1	2	3	4	RM-200XF	RM-200X
1	ON	OFF	OFF	OFF		
2	OFF	ON	OFF	OFF		
3	ON	ON	OFF	OFF		
4	OFF	OFF	ON	OFF		
5	ON	OFF	ON	OFF		
6	OFF	ON	ON	OFF		
7	ON	ON	ON	OFF		
8	OFF	OFF	OFF	ON		

**Note**

Settings not included in the above table should be considered invalid, and correct operation of such invalid settings cannot be assured. Ensure that each switch is set for every one of positions indicated above.

### 1.1.3. Microphone input sensitivity adjustment using Level Meter Mode (Switch 5)

Setting the Level Meter Mode to ON permits the Remote Microphone's level meter LED to indicate the input signal level only while announcements are made from the microphone. Microphone input sensitivity can be correctly adjusted by speaking into the microphone while observing the LED level indication. When the microphone is not used for announcement broadcasts, this LED provides normal indications (i.e. Programmed function key operations).

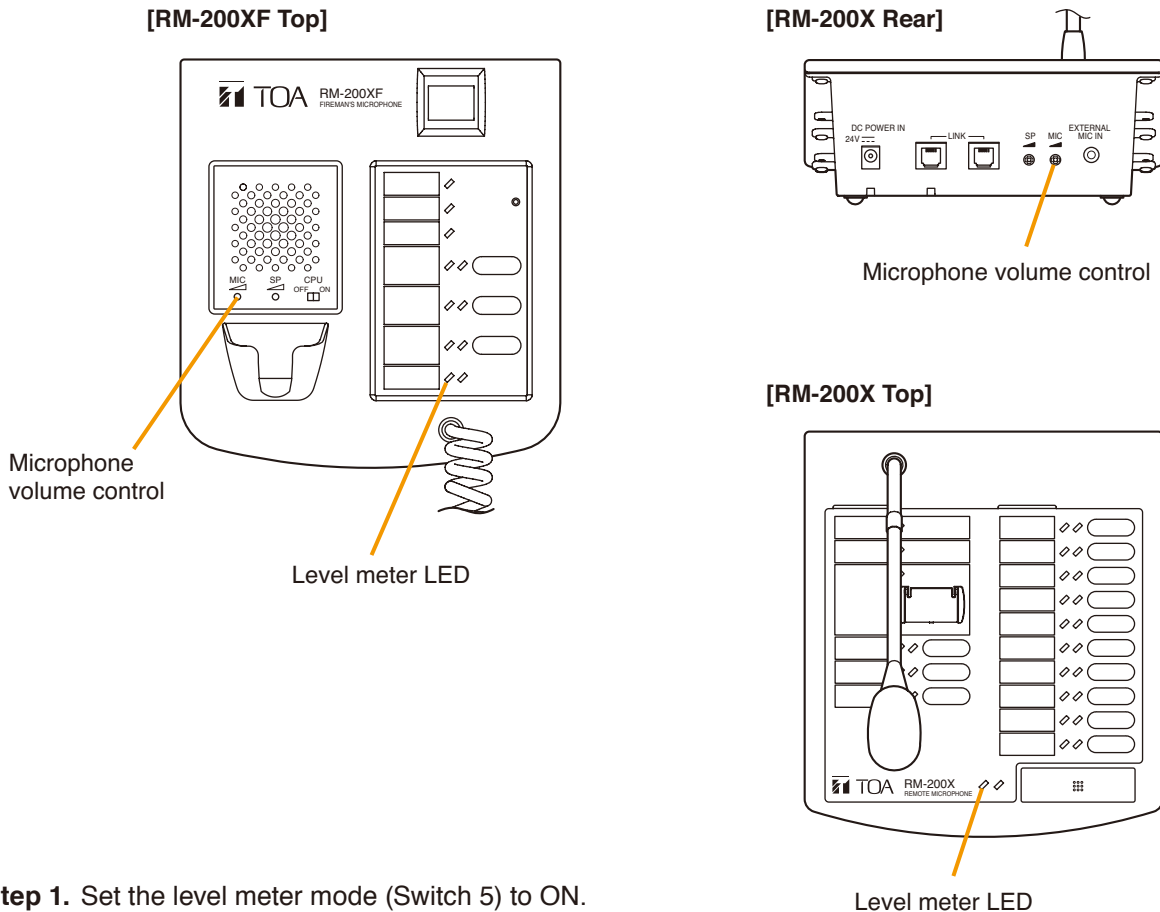

**Step 1.** Set the level meter mode (Switch 5) to ON.

**Step 2.** Speak into the microphone.

The Remote microphone's level meter LED indicates the input signal level. The following table shows the input level associated with each LED indication.

LED Indication Colour	Input Signal Level
Lights red	Over 0 dB
Lights green	-20 to 0 dB <span style="color: red;">——</span> Correct level
Off	Under -20 dB

**Step 3.** Adjust the microphone input sensitivity with the microphone volume control so that the level meter LED lights green.

**Step 4.** Set the level meter mode back to OFF.

#### Notes

- Set the mode to OFF during actual system operation.
- The Level Meter Mode is factory-preset to ON.

### 1.1.4. Compression settings (Switch 6)

When the compression circuitry is set to ON, broadcasts can be made without voice distortion, even during loud outbursts. Compression is factory-preset to ON.

### 1.1.5. Enable/Disable switching for the Emergency button and Function key 2 (Switches 7 and 8, and RM-200XF only)

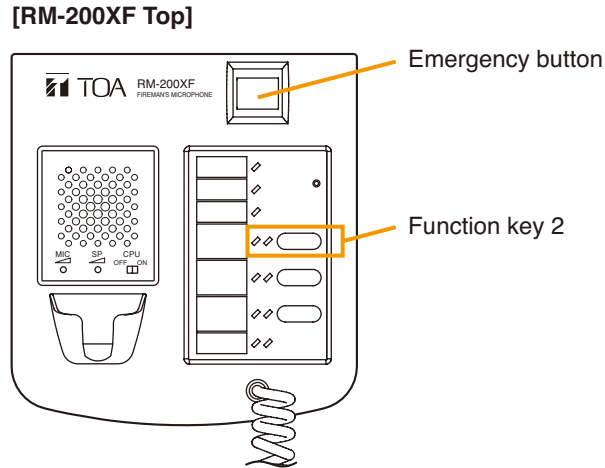

Both functions of the Emergency button and Function key 2 are factory-preset for "OFF" (Enable). Selecting "ON" disables the Emergency button or Function key 2 operation, allowing it only to function as an indicator.

Use this setting, for example, when Emergency activation from the RM-200XF is not desired but only emergency mode indication is needed.

For details of the remote microphone indications, refer to [p. 4-7](#).

Setting DIP Switch	Function	Operation
7	OFF	The Emergency button operates normally.
	ON	The Emergency button will not perform Emergency activation, but provides only an indication for emergency mode.
8	OFF	The Function key 2 operates normally.
	ON	The Function key 2 will not operate, but provides the indications of the assigned function. Example: When the function "Evacuation EV message recall" is assigned, the indication provides the status of the evacuation EV message broadcast.

## 1.2. RM-200XF Wall Mounting

### [Necessary mounting hardware]

The parts required for mounting the RM-200XF to a wall are included with the unit as accessories.

Wall mounting bracket .....	1 (supplied with the RM-200XF)
Wall mounting screw .....	2 (supplied with the RM-200XF)
Box mounting screw .....	2 (supplied with the RM-200XF)

**Step 1.** Attach the wall-mounting bracket to the wall.

### WARNING

- Install the unit only in a location that can structurally support the weight of the unit and the mounting bracket. Doing otherwise may result in the unit falling down and causing personal injury and/or property damage.
- Be sure to use at least 2 screws when mounting the bracket to the wall.

**Step 2.** Wire the supplied 9P plug-in screw terminal, and plug it into the LINK terminal on the bottom surface of the RM-200XF.

**Step 3.** Hook the bottom of the RM-200XF onto the installed mounting bracket.

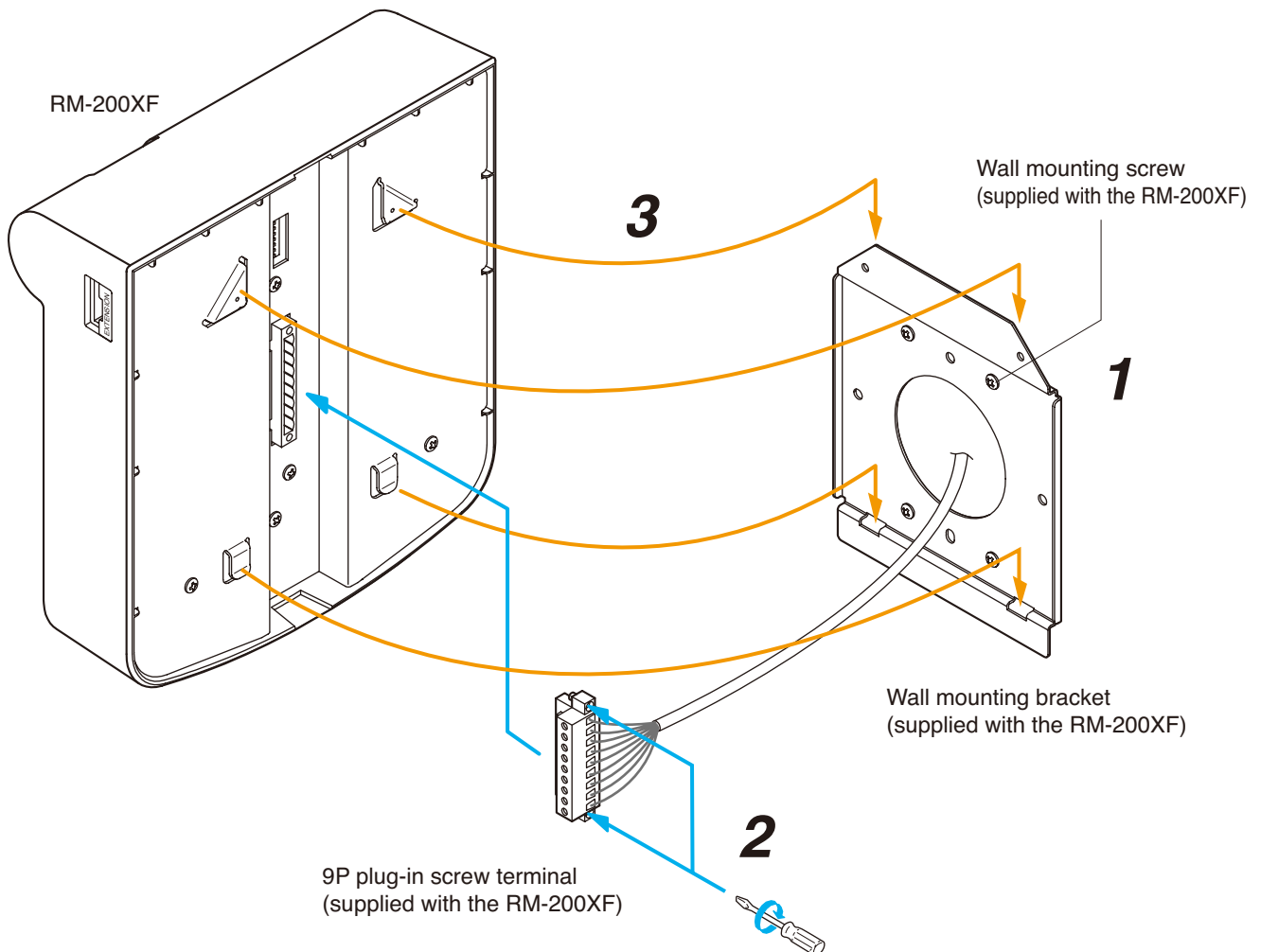



When the RM-200XF is installed in a wall box (prepare separately), the box should measure at least 300 mm wide x 315 mm high as illustrated below.

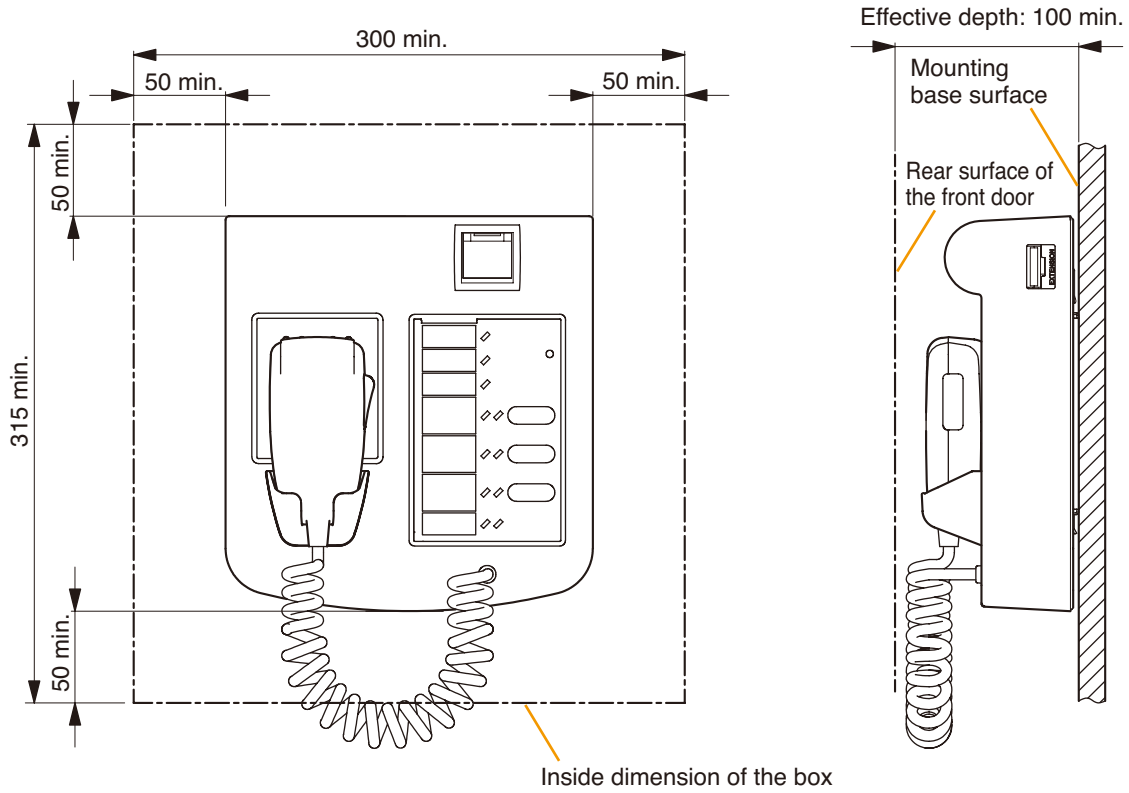

Unit: mm

### 1.3. Mounting the Assembly of RM-200XF and Its Extension RM-210 on a Wall

When adding an RM-210 Remote Microphone Extension to expand the RM-200XF, use the optional WB-RM200 Wall Mounting Bracket.

**[Necessary mounting hardware for adding the RM-210]**

As the mounting bracket for the RM-210 is an optional product (model WB-RM200), prepare it separately.

- Wall mounting bracket for the RM-210 (model WB-RM200) ..... 1 (optional)
- M3.5 screw for wiring box ..... 2 (supplied with the WB-RM200)
- Tapping screw for wooden wall ..... 2 (supplied with the WB-RM200)

**Step 1.** Attach the RM-200XF and RM-210 wall-mounting brackets to the wall.

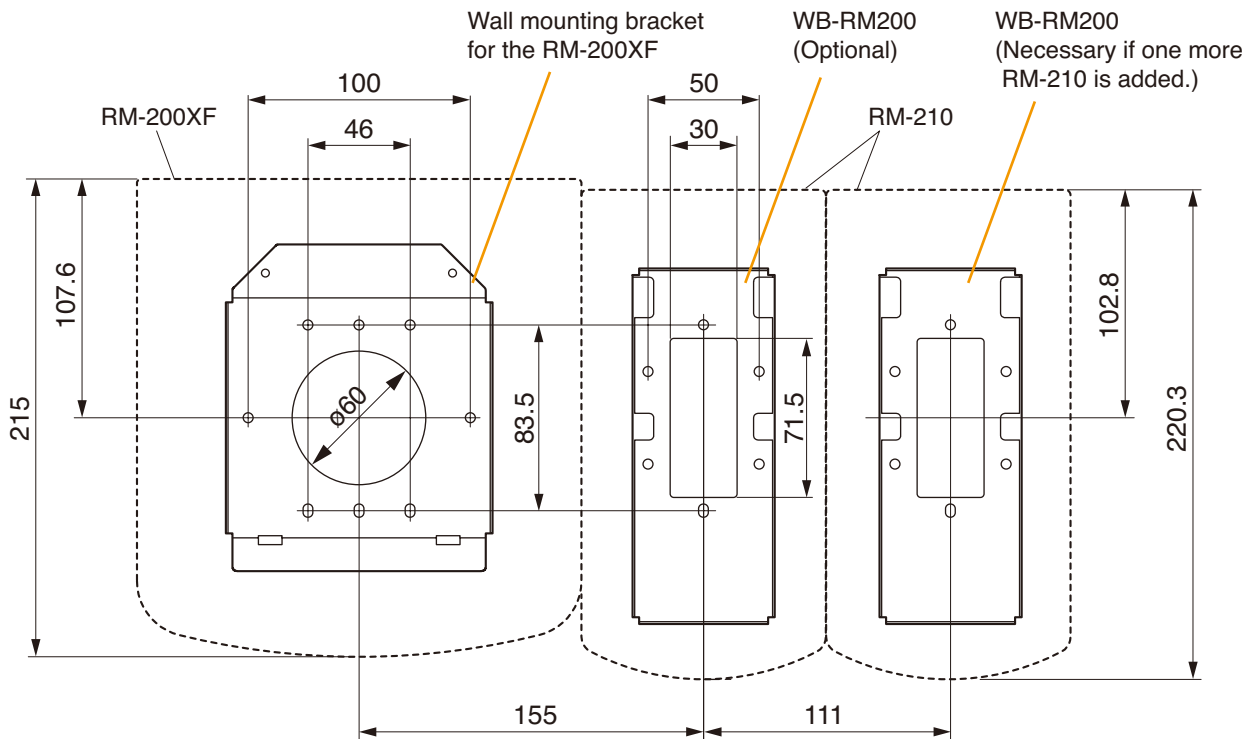

Unit: mm

## **! WARNING**

- Install the unit only in a location that can structurally support the weight of the unit and the mounting bracket. Doing otherwise may result in the unit falling down and causing personal injury and/or property damage.
- Be sure to use at least 2 screws when mounting the bracket to the wall.

*Continued on next page*

**Step 2.** Mount the RM-200XF to the wall.

For the installation method, refer to p. 8-6 "1.2. RM-200XF Wall Mounting."

**Step 3.** Using the extension cable supplied with the RM-210, connect the RM-200XF's side EXTENSION connector to the RM-210's side EXTENSION connector.

**Step 4.** Hook the bottom surface of the RM-210 onto its mounting bracket.

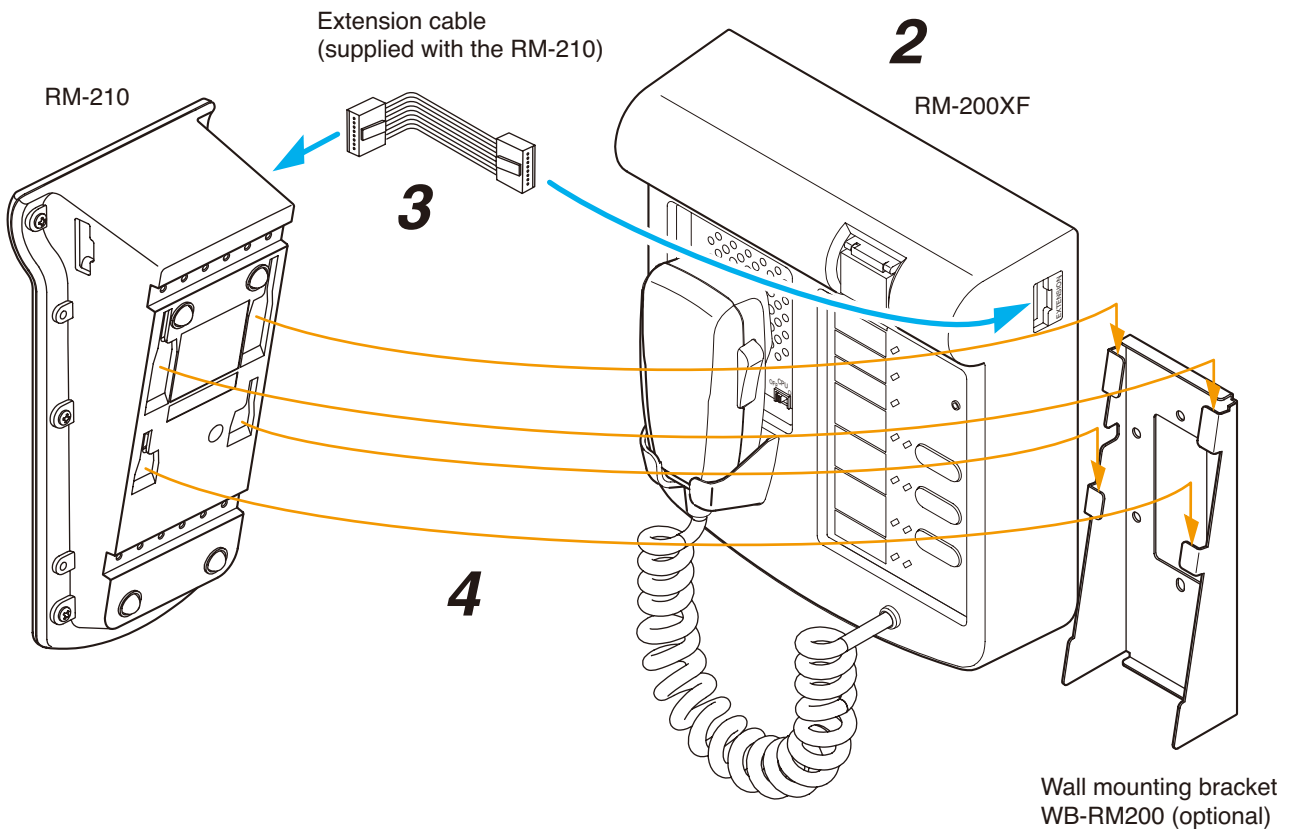

## 1.4. RM-200X Wall Mounting

### [Necessary mounting hardware]

To mount the RM-200X to the wall, the following parts are required.

Wall mounting bracket for the RM-210 (model WB-RM200) .....	1	(optional)
M3.5 screw for wiring box .....	2	(supplied with the WB-RM200)
Tapping screw for wooden wall .....	2	(supplied with the WB-RM200)

**Step 1.** Attach the WB-RM200 Wall-Mounting Bracket to the wall.  
In this case, leave the LINK cable out of the notch in the bracket.

## WARNING

- Install the unit only in a location that can structurally support the weight of the unit and the mounting bracket. Doing otherwise may result in the unit falling down and causing personal injury and/or property damage.
- Be sure to use 2 screws when mounting the bracket to the wall.

**Step 2.** Hook the bottom surface of the RM-200X onto the WB-RM200.

**Step 3.** Plug the LINK cable into the RM-200X's LINK terminal.

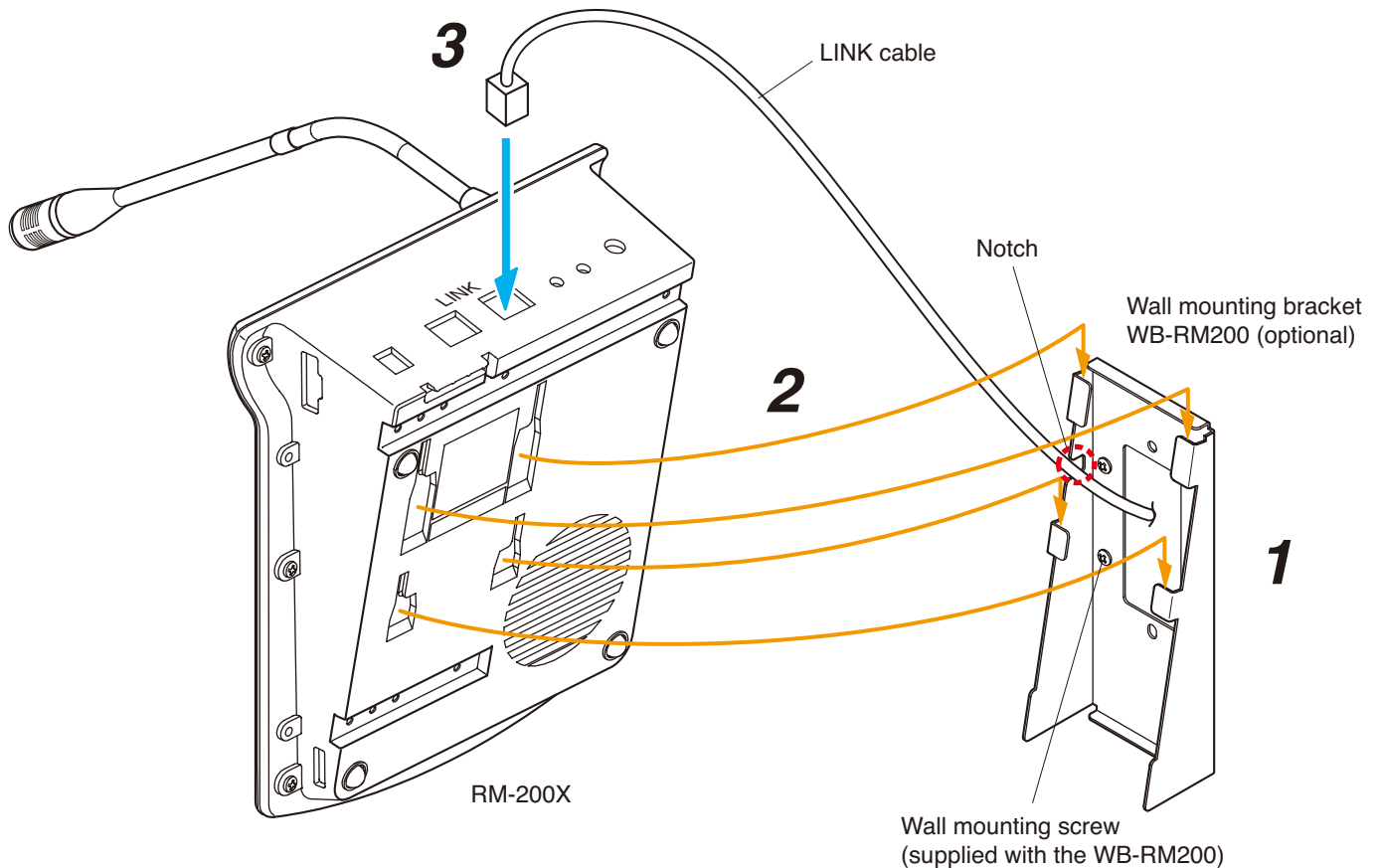

## 1.5. Mounting the Assembly of RM-200X and Its Extension RM-210 on a Wall

When adding an RM-210 Remote Microphone Extension to expand the RM-200XF, use the optional WB-RM200 Wall Mounting Bracket.

### [Necessary mounting hardware for adding the RM-210]

As the mounting bracket for the RM-210 is an optional product (model WB-RM200), prepare it separately.

Wall mounting bracket for the RM-210 (model WB-RM200) .....	1	(optional)
M3.5 screw for wiring box .....	2	(supplied with the WB-RM200)
Tapping screw for wooden wall .....	2	(supplied with the WB-RM200)

**Step 1.** Attach the 2 WB-RM200 Wall-Mounting Brackets (one for the RM-200X and one for the RM-210) to the wall.

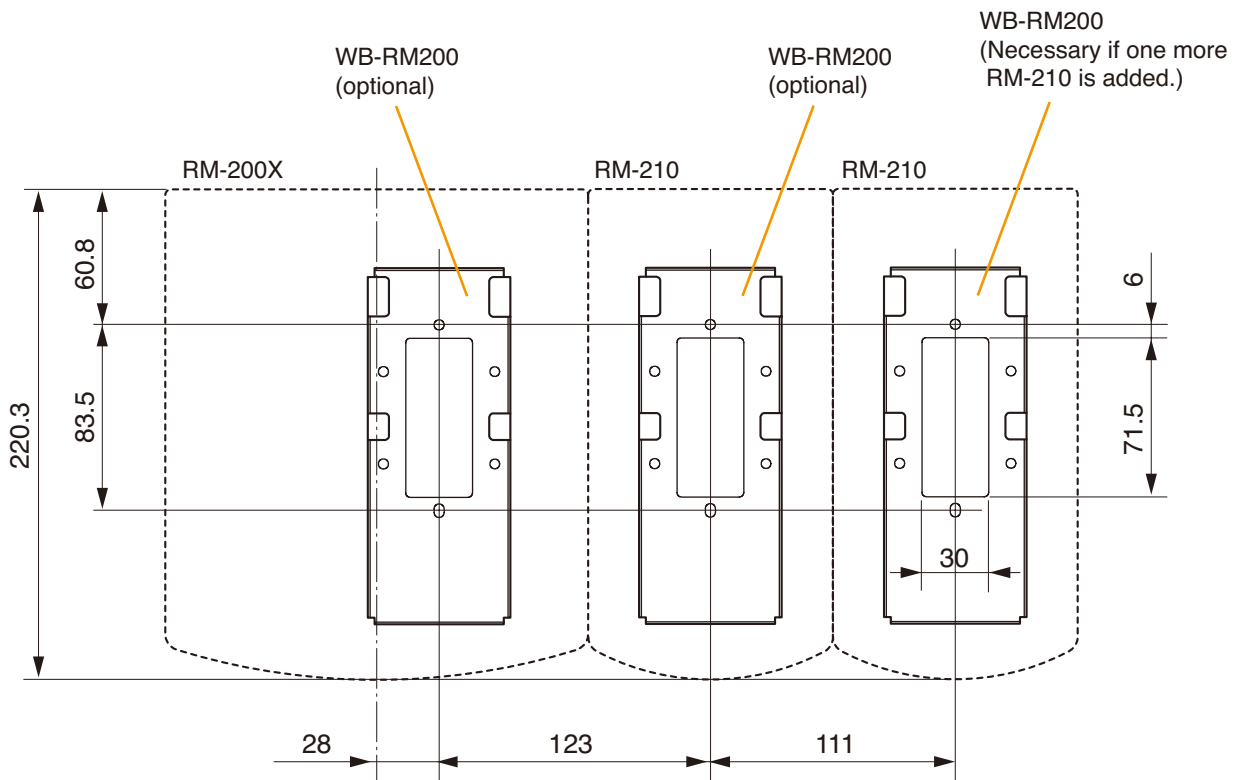

Unit: mm

## **!** WARNING

- Install the unit only in a location that can structurally support the weight of the unit and the mounting bracket. Doing otherwise may result in the unit falling down and causing personal injury and/or property damage.
- Be sure to use 2 screws when mounting the bracket to the wall.

*Continued on next page*

**Step 2.** Mount the RM-200X to the wall.

For the installation method, refer to p. 8-10 "1.4. RM-200X Wall Mounting."

**Step 3.** Using the extension cable supplied with the RM-210, connect the RM-200X's side EXTENSION connector to the RM-210's side EXTENSION connector.

**Step 4.** Hook the bottom surface of the RM-210 onto its mounting bracket.

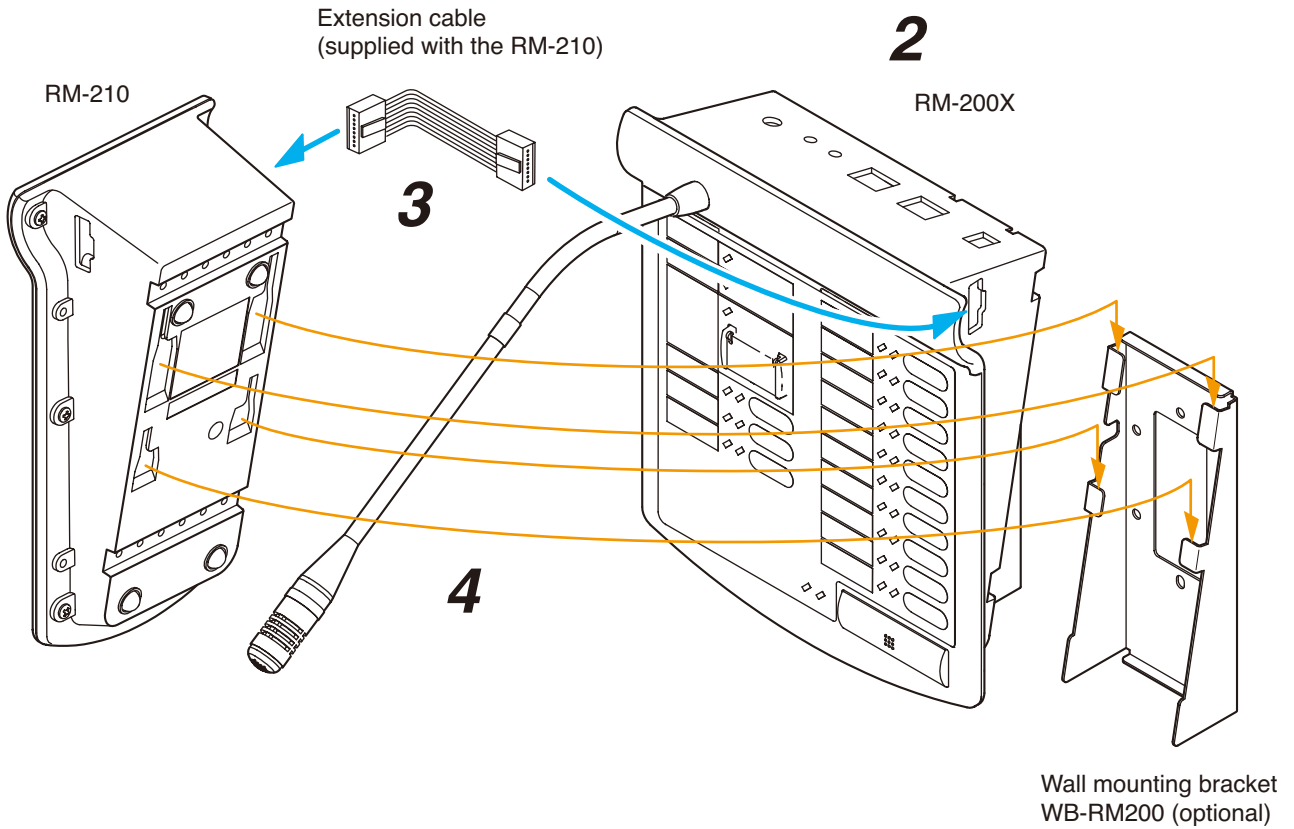

### 1.6. RM-200X Expansion With the Addition of the RM-210 (Installed on a Flat Surface)

When adding an RM-210 Remote Microphone Extension to expand the RM-200X, use the RM-210's Extension cable and included Linkage Bracket to link the 2 microphones.

**[Necessary hardware]**

The parts required to add the RM-210 are included with the unit.

- Linkage Bracket A ..... 2
- Linkage Bracket B ..... 1
- Screw ..... 12

**Step 1.** Turn over both the RM-200X and the RM-210, and keep them in close contact with each other.

**Step 2.** Connect between both units using the extension cable.

**Step 3.** Using 4 supplied screws (marked with [➔] in the figure) and Linkage Bracket B, link both units together.

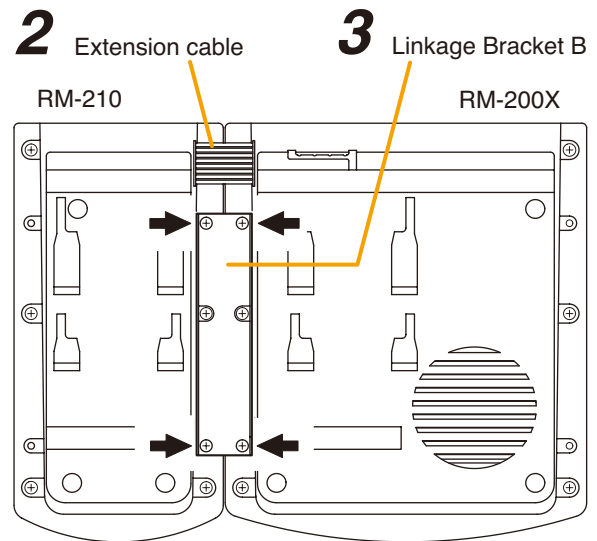

[Bottom side]

**Step 4.** Using 8 supplied screws ([➔] marking) and 2 pieces of Linkage Bracket A, fix both units securely.

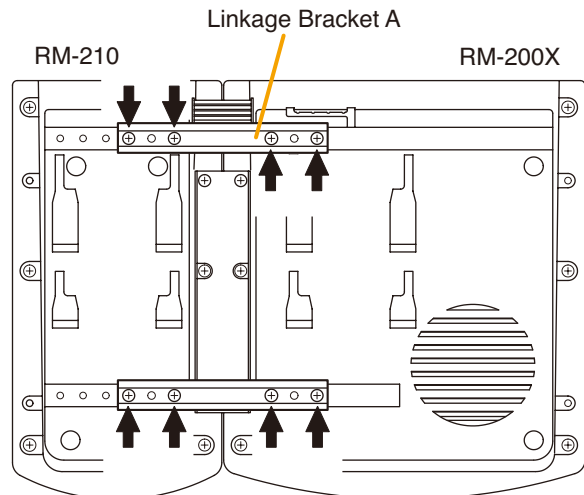

[Bottom side]

**Notes**

- Because the Linkage Bracket A is provided with 2 spare screw holes, use them to link the 2 units if the designated screw threaded holes are damaged.
- If incorrect or loose connection is found between both units, loosen all the bracket fixing screws to disassemble the units and then link them again with the screws.

## 1.7. Creating Remote Microphone Name Labels

Using the VX-2000 System Setting Software function, assigned names of preset RM-200XF, RM-200X, and RM-210 Function keys can be printed out. Once printed, cut out the printed names with scissors to use them as corresponding name labels. The paper used for the name label must be under 0.2 mm in thickness.

### [Inserting the name label]

- Fully insert the name label cut to the instructed size into the label entry slit.
- To remove the label, pull it out of the slit using the tip of knife blade.

### [Example of printed out RM-200XF name label]

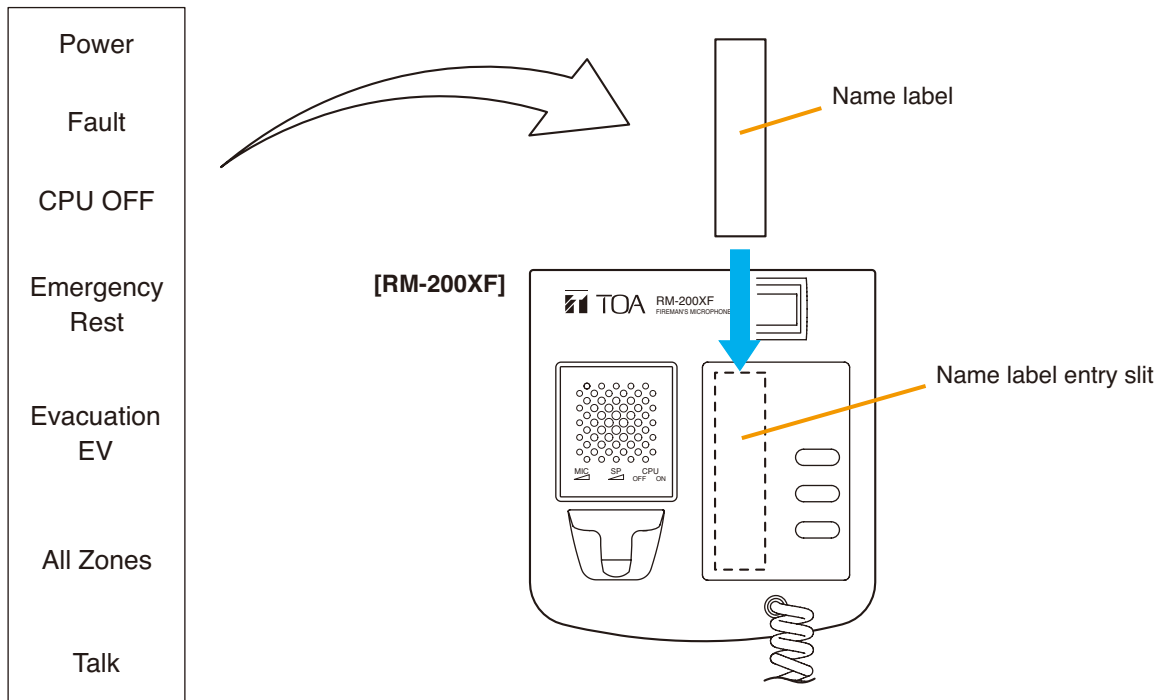



## 2. VX-2000, VX-200XR, VX-200XI, AND EV-200

### 2.1. Removing the VX-2000's Top and Front Panels

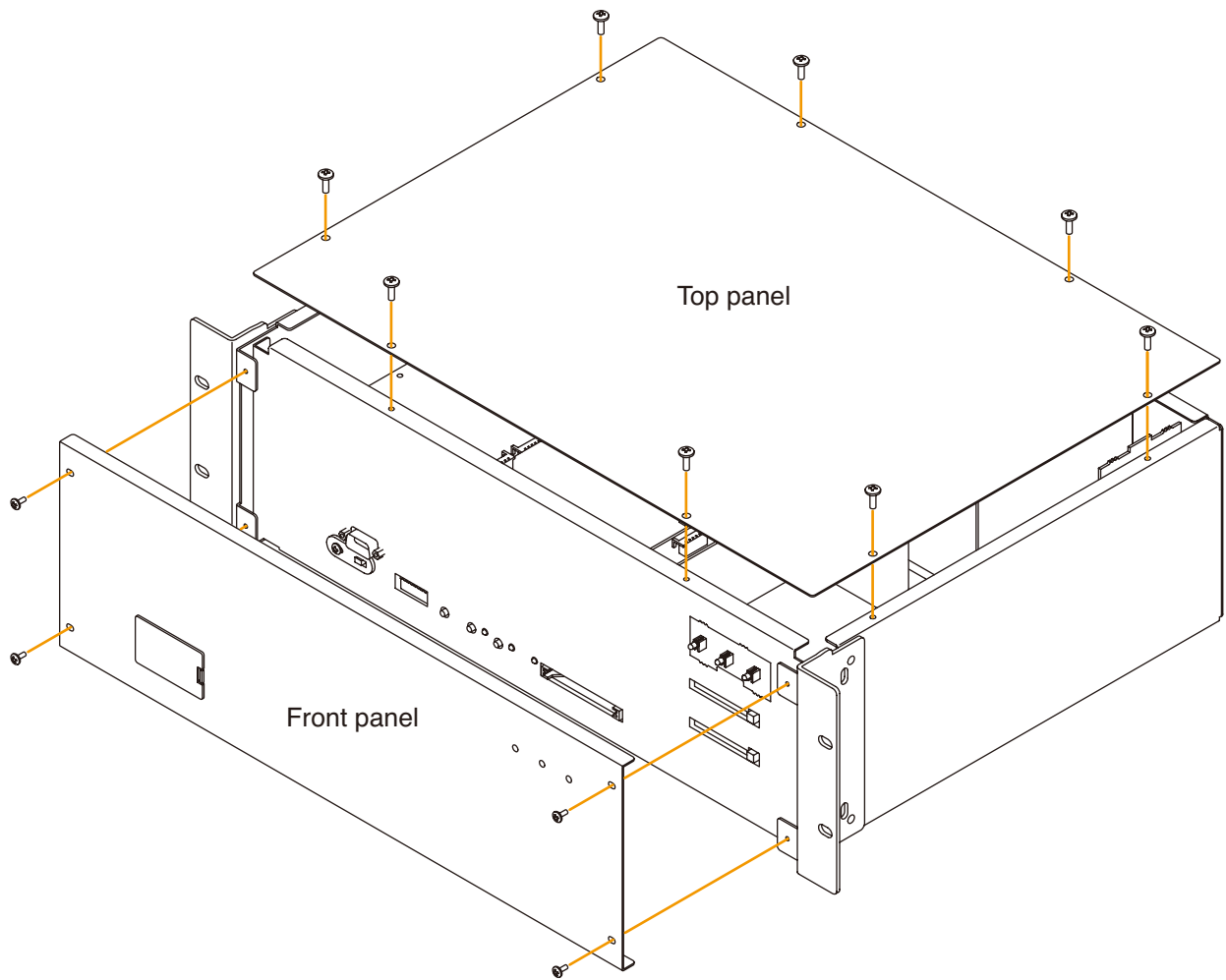

## 2.2. Changing the RS-232C Connector Location

The RS-232C connector located in the pocket on the VX-2000 System Manager front panel can be relocated to the VX-2000's rear panel.

**Step 1.** Remove both the top and front panels.

Refer to [p. 8-15](#) "2.1. Removing the VX-2000's Top and Front Panels."

**Step 2.** Press on the blank panel over the rear-mounted RS-232C connector receptacle from the outside. Then, wrench it off from the inside.

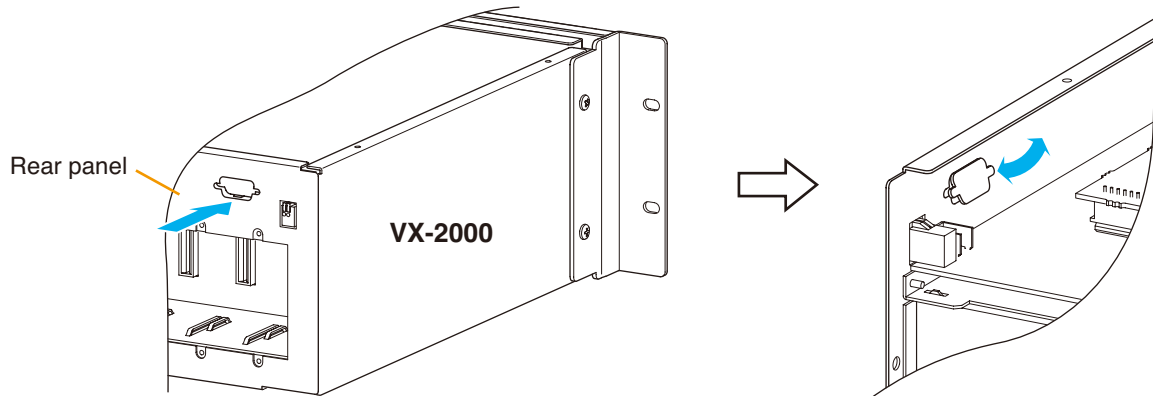

**Step 3.** Unscrew the hexagonal sleeves (2 pieces) holding the RS-232C connector, and detach the RS-232C connector (with circuit board attached) from the panel chassis.

**Step 4.** Cut a cable tie with nippers.

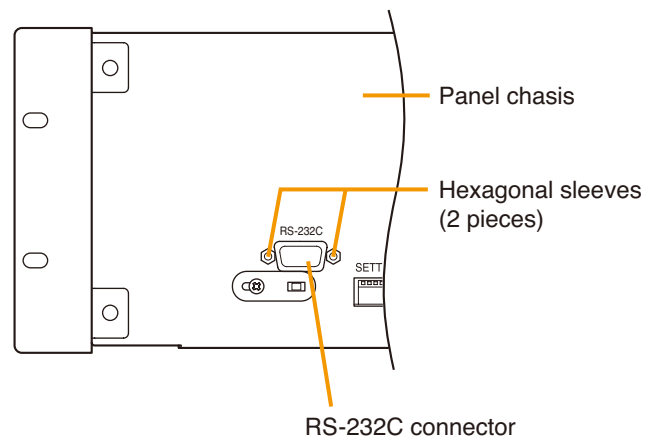

**Step 5.** Screw the RS-232C connector to the rear panel using the hexagonal sleeves removed in **Step 3**.

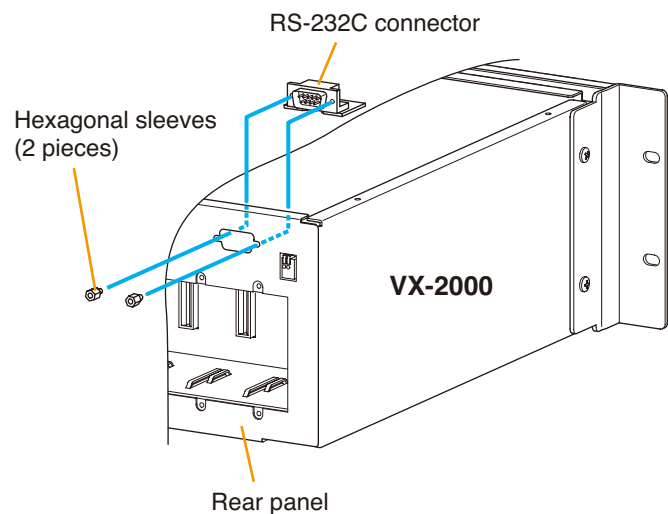

**Step 6.** Replace both the top and front panels.

### Note

Take care not to pinch the RS-232C cable between the top panel and chassis.

## 2.3. Insulating the VX-2000 Control I/O

Because the VX-2000's control inputs and outputs employ photocouplers, they can be insulated by performing the following settings to be powered from external equipment.

**Step 1.** Remove the top panel.

Refer to p. 8-15 "2.1. Removing the VX-2000's Top and Front Panels."

**Step 2.** Perform the setting.

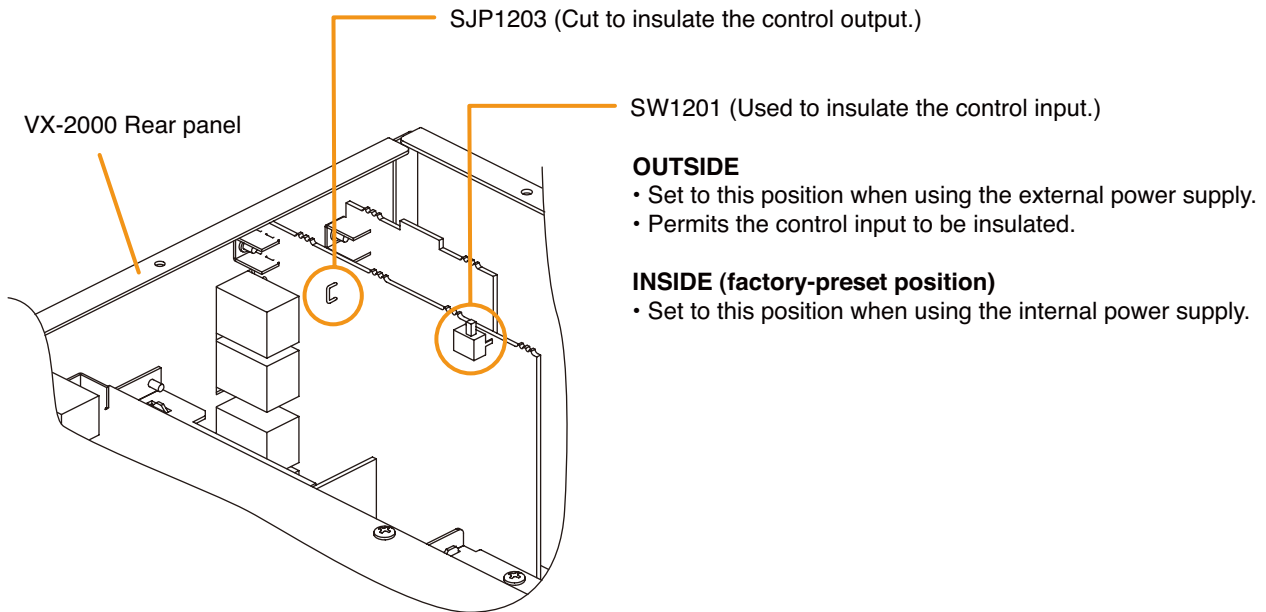

**2-1.** Insulating the Control input

Shift the SW1201 switch to the OUTSIDE position. This switch is factory-preset to the INSIDE position.

**2-2.** Insulating the Control output

Cut SJP1203.

**Step 3.** Replace the top panel.

## 2.4. Installing the Insulating Transformer in the VX-2000 System Manager

Audio buses between the VX-2000 System Manager and the VX-2000SF Surveillance Frame can be insulated by installing the optional IT-450 Insulating Transformers.

### WARNING

The insulating transformer cannot be installed without removing the circuit board inside the VX-2000. Make sure that the system power is switched OFF before commencing installation. For procedures regarding switching off the system power, refer to the Instruction Manual attached to the VX-2000DS/3000DS.

**Step 1.** Remove the top panel.

Refer to p. 8-15 "2.1. Removing the VX-2000's Top and Front Panels."

**Step 2.** Remove the transformer boards (OT PCBs).

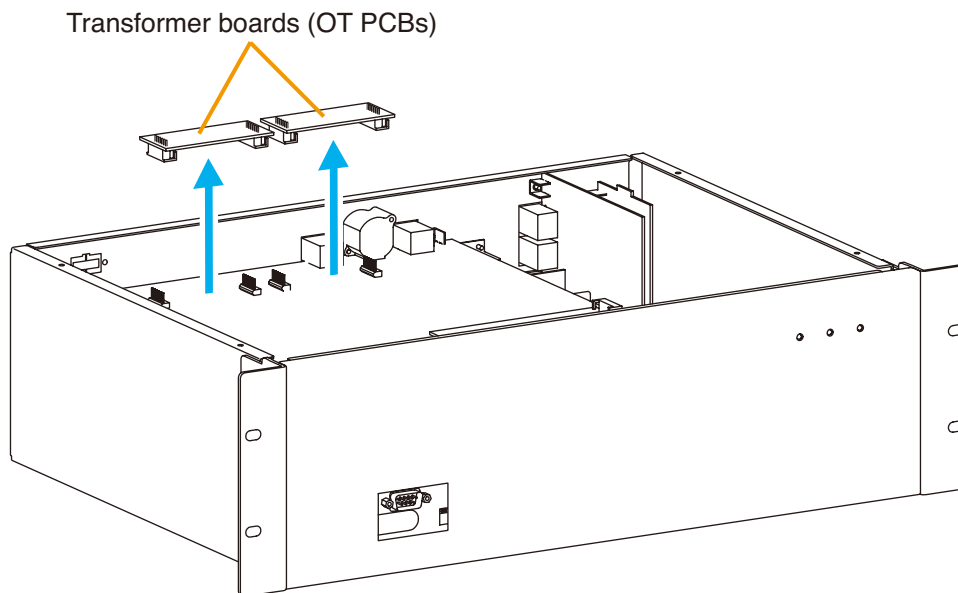

**Step 3.** Cut the jumper wires installed on each transformer board.

(4 jumpers SJP1401 - SJP1404 on each OT PCB.)

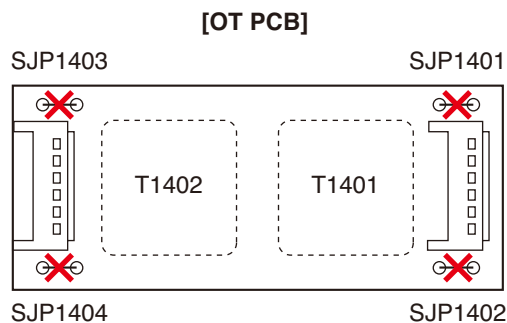

**Step 4.** Solder the IT-450 transformers to locations T1401 and T1402 on each OT PCB.

**Step 5.** Fit both OT PCBs back into place.

**Step 6.** Replace the top panel.

## 2.5. Mounting the EV-200 Voice Announcement Board on the VX-2000 System Manager

Do not handle unless your body is static-free because some of the assembled components are sensitive to static electricity.

**Step 1.** Confirm the DIP switch on the EV-200 Board is set for the factory-preset position as shown in the figure.

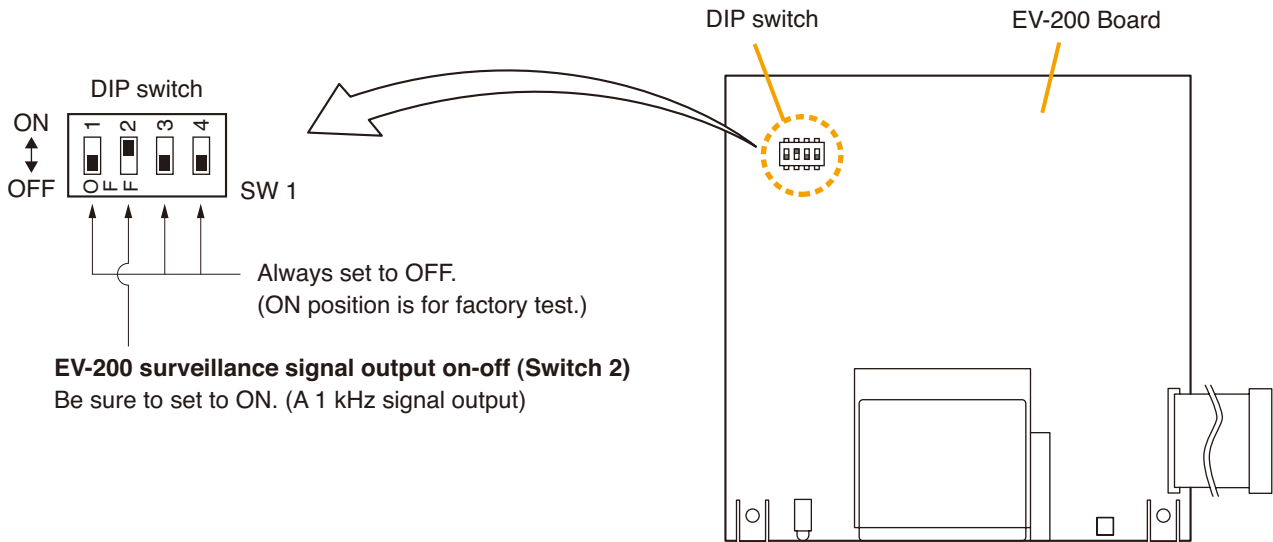

### EV-200 surveillance signal output (Switch 2)

The EV-200 board continuously transmits a 1 kHz sine wave signal to the VX-2000 System Manager when the EV-200 Board is not reproducing audio signals. The VX-2000 detects the existence of the 1 kHz signal. When the 1 kHz signal does not exist with the EV-200 not in use, the VX-2000 judges the board's failure and causes the FAULT indicator to light.

**Step 2.** Remove both the top and front panels.

Refer to [p. 8-15](#) "2.1. Removing the VX-2000's Top and Front Panels."

The figure below is the top view of VX-2000 inside. The EV1 and EV2 connectors are used to connect EV-200 boards.

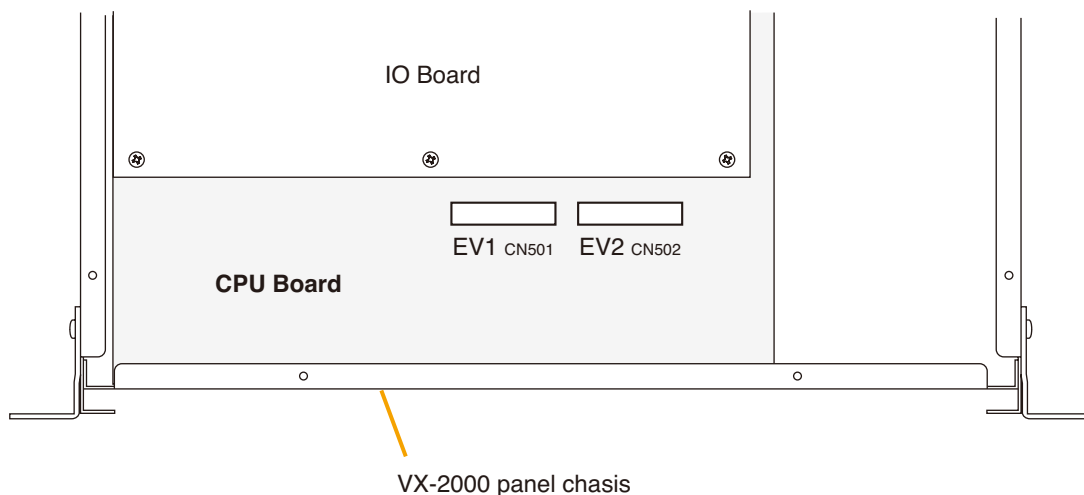

**Step 3. Mount the EV-200.****3-1. When using a single EV-200 unit**

**3-1-1.** Using the 2 screws supplied with the EV-200, mount the EV-200 in "Position 1" in the VX-2000.

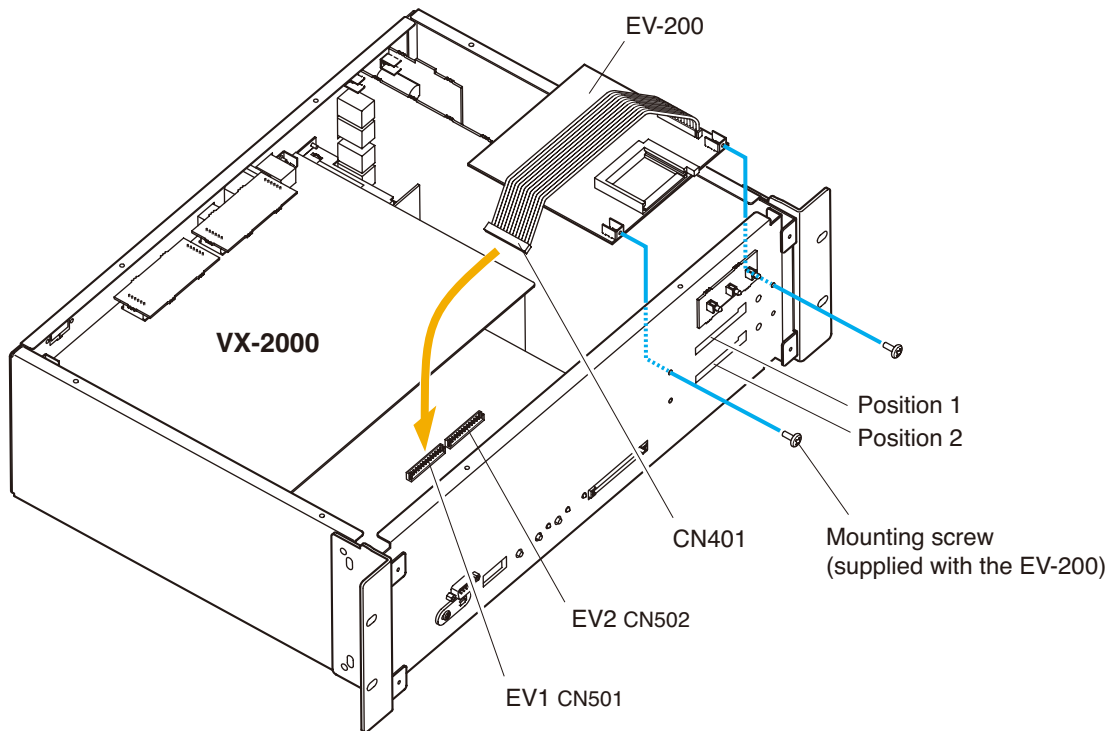

**3-1-2.** Plug the EV-200's CN401 connector into the "EV1" connector (CN501) on the VX-2000's circuit board.

**Note:** The EV-200 will not operate correctly if the CN401 is plugged into the "EV2" connector (CN502).

**3-2. When using 2 EV-200 units**

The mounting position is determined by the type of emergency message recorded on the CF card mounted in the EV-200.

Message Type	Mounting Position	Connected Connector
Alert	"Position 1"	(EV1) CN501
Evacuation	"Position 2"	(EV2) CN502

Perform "Position 2" mounting first, followed by "Position 1".

**3-2-1.** Using the 2 supplied screws, mount the EV-200 (Evacuation message) in "Position 2" of the VX-2000. For the mounting method, refer to **Step 3-1-1** above.

**3-2-2.** Plug the CN401 connector from the EV-200 (Evacuation message) into the "EV2" (CN502) connector on the VX-2000's circuit board.

**3-2-3.** Mount the EV-200 (Alert message) in "Position 1" of the VX-2000 in the same way as **Step 3-2-1** above.

**3-2-4.** Plug the CN401 connector from the EV-200 (Alert message) into the "EV1" (CN501) connector on the VX-2000's circuit board.

**Step 4. Replace both the top and front panels.**

## 2.6. Setting the VX-200XI Audio Input Module DIP Switch

Input sensitivity (MIC:  $-70$  dB\* or LINE:  $-20$  dB\*) and phantom power ON/OFF settings can be performed using the DIP switch on the VX-200XI circuit board.

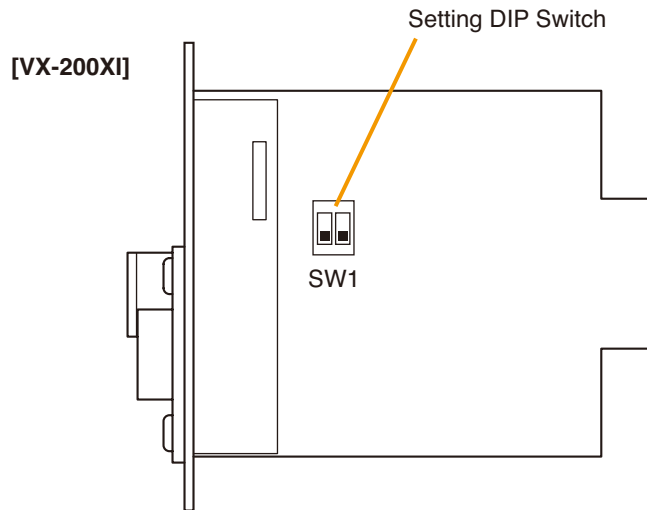

### [DIP Switch Setting]

Setting Item	Switch No.	1 Phantom Power	2 Input Sensitivity	Switch Position
Input sensitivity: LINE ( $-20$ dB*) Phantom power: OFF		OFF	OFF	
Input sensitivity: MIC ( $-70$ dB*) Phantom power: OFF		OFF	ON	
Input sensitivity: MIC ( $-70$ dB*) Phantom power: ON		ON	ON	

\* 0 dB = 1 V

### Notes

- Set the phantom power to OFF when the input sensitivity is set to LINE.
- Input sensitivity is factory-preset to LINE and the phantom power is preset to OFF.

## 2.7. Insulating the VX-200XI Control and Audio Inputs

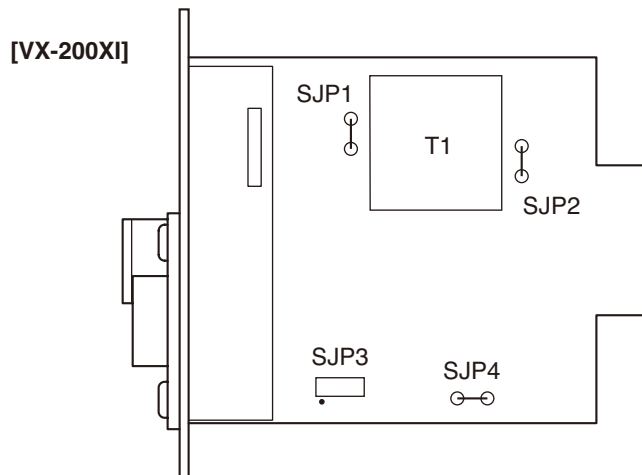

Because the VX-200XI control input employs photocouplers, the control input can be insulated through the following settings.

Circuit Symbol	Setting
SJP3	Change the short circuit socket position.  Factory-preset position
SJP4	Cut this jumper.

To insulate the audio input, mount the optional transformer IT-450 following the table below.

Circuit Symbol	Setting
SJP1	Cut this jumper.
SJP2	Cut this jumper.
T1	Mount and solder the IT-450 transformer.



## 2.8. Mounting the VX-200XR and VX-200XI in the VX-2000 System Manager

### Notes

- The slot number and module type to be installed must be identical to those designated by the PC software.
- Cover idle slots with the supplied blank panels to prevent dust from getting into the equipment.

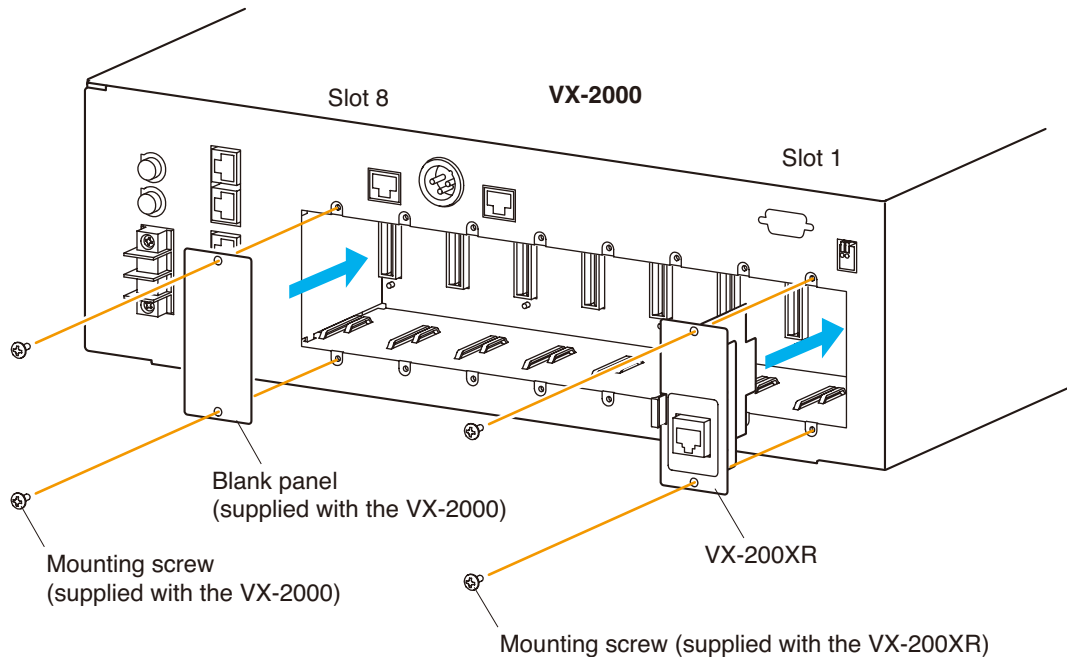

## 2.9. VX-2000 System Manager's DIP Switch Settings

### 2.9.1. DIP switch functions

[VX-2000 Front panel detached]

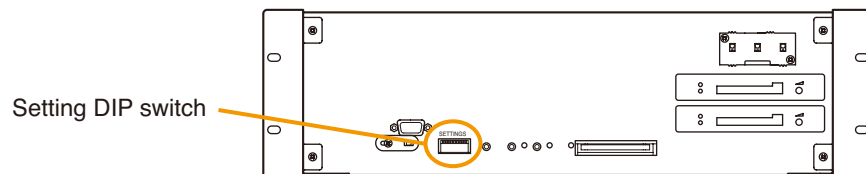

### [DIP switch settings]

Switch No.	1	2	3	4	5	6	7	8
Function	Unused			UK standby mode ON/OFF		Unused		

**Note:** Leave all switches except 5 OFF.

### 2.9.2. Setting the VX-2000's UK standby mode (switch 5)

**[Switch 5 setting]** ON: UK standby mode  
OFF: Normal mode

When power fails, the VX-2000 turns into the UK standby mode, permitting general broadcast from both the RM-200XF and the Emergency type RM-200X.

### Attention

The standby mode is provided for emergency activation in power failure. To ensure operation in the UK standby mode, prepare sufficient battery capacity or pay attention to make announcements from emergency type remote microphones as briefly as possible in order to prevent excessive battery consumption.

### Notes

- This function applies to the version 2.10 or later firmware (VX-2000 and VX-2000SF).
- The VX-2000SF requires no setting.
- The selected mode (UK standby or normal) is made valid after the VX-2000 is reset.

### 3. VX-2000SF, VX-200SZ, VX-200SP, VX-200SI, VX-200SO, AND VX-200SE

#### 3.1. VX-2000SF Surveillance Frame's DIP Switch Settings

##### 3.1.1. DIP switch functions

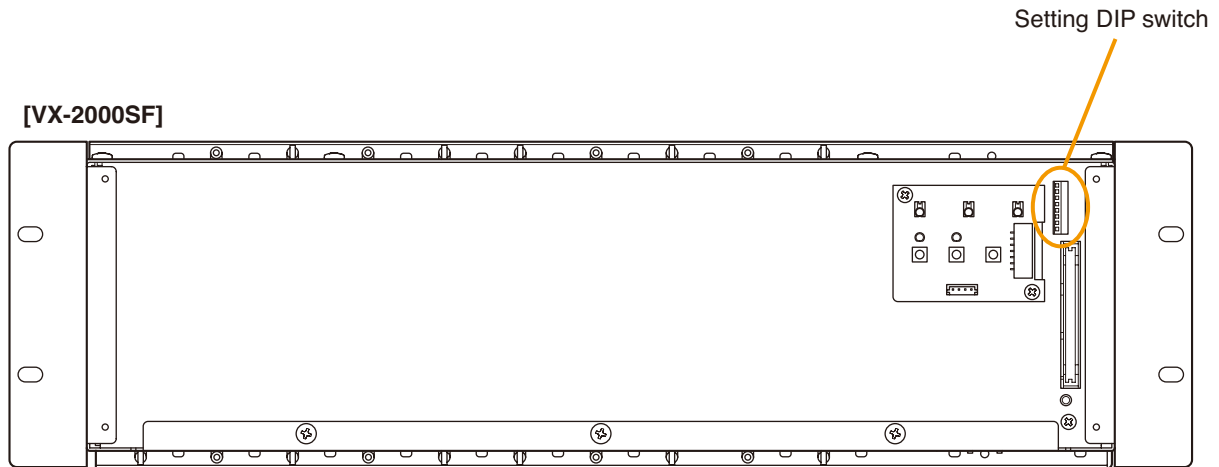

##### [DIP switch settings]

Switch No.	1	2	3	4	5	6	7	8
Function	Unused				Terminator ON/OFF	Unit ID No. setting		

**Note:** Leave the switches 1 – 4 OFF.

### 3.1.2. Setting the unit ID number for the VX-2000SF Surveillance Frame

Up to 5 VX-2000SF can be connected per system. Unit ID numbers of 1 – 8 need to be set for each Frame.

#### [VX-2000SF's Unit ID Number]

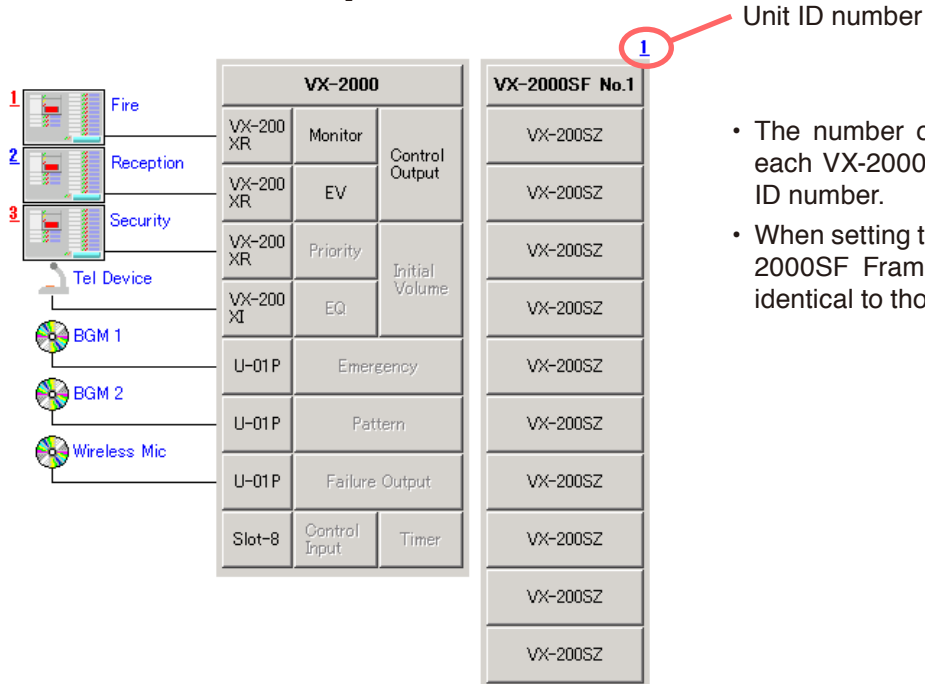

- The number on the right-hand side above each VX-2000SF symbol indicates the Unit ID number.
- When setting the Unit ID Number for the VX-2000SF Frame, the ID Numbers must be identical to those set by the PC software.

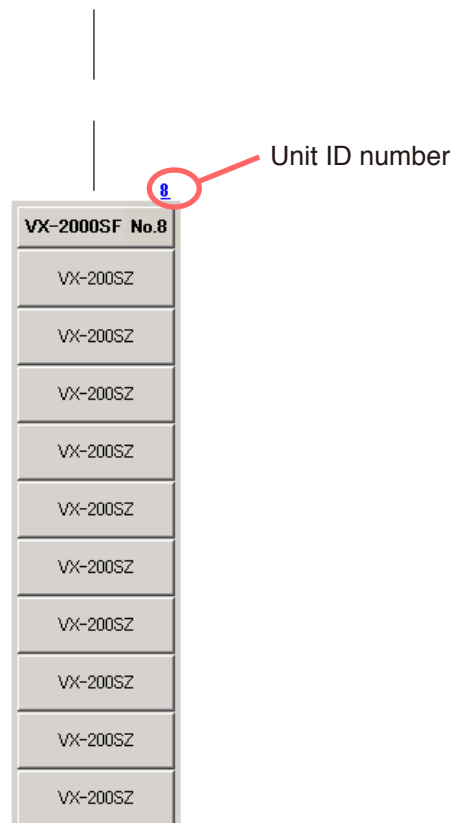

**[Unit ID Number setting]**

Use the DIP switch inside the front panel when setting the Unit ID Number. Refer to the following table for the DIP switch settings.

Unit ID Number Switch No.	1	2	3	4	5	6	7	8
8	ON	OFF	ON	OFF	ON	OFF	ON	OFF
7	OFF	ON	ON	OFF	OFF	ON	ON	OFF
6	OFF	OFF	OFF	ON	ON	ON	ON	OFF
Switch Position								

**Notes**

- Settings not included in the above table should be considered invalid, and correct operation of such invalid settings cannot be assured. Ensure that each switch is set for every one of positions indicated above.
- The Unit ID Number is factory-preset to "1."
- The Unit ID Number must be the same as that which is set by the PC software.

**3.1.3. Setting the VX-2000SF's terminator (switch 5)**

The VX-2000SF connected last needs to have its terminator on the communication line switched ON. The terminator setting is performed using the unit's front-mounted DIP switch (No.5).

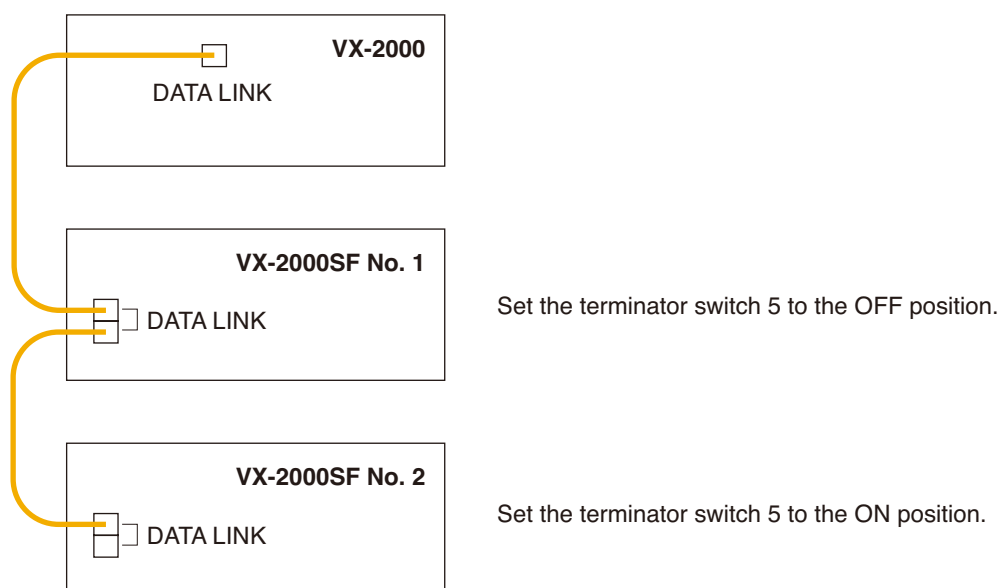
**Notes**

- Be sure to set the terminator correctly because the wrong setting causes the system malfunction.
- When the system includes a single VX-2000SF unit, switch its terminator to the ON position.
- The terminator switch is factor-preset to the OFF position.

### 3.2. Installing the Insulating Transformer in the VX-2000SF Surveillance Frame

Audio links between the VX-2000 System Manager and the VX-2000SF Surveillance Frame can be insulated by installing the optional IT-450 Insulating Transformer.

## WARNING

The insulating transformer cannot be installed without removing the circuit board inside the VX-2000SF. Make sure that the system power is switched OFF before commencing installation. For procedures regarding switching off the system power, refer to the Instruction Manual attached to the VX-2000DS/3000DS.

**Step 1.** Remove all mounted modules and blank panels.

**Step 2.** Detach the transformer boards (OT PCBs) from the ABL (Analog Bus Link) circuit board.

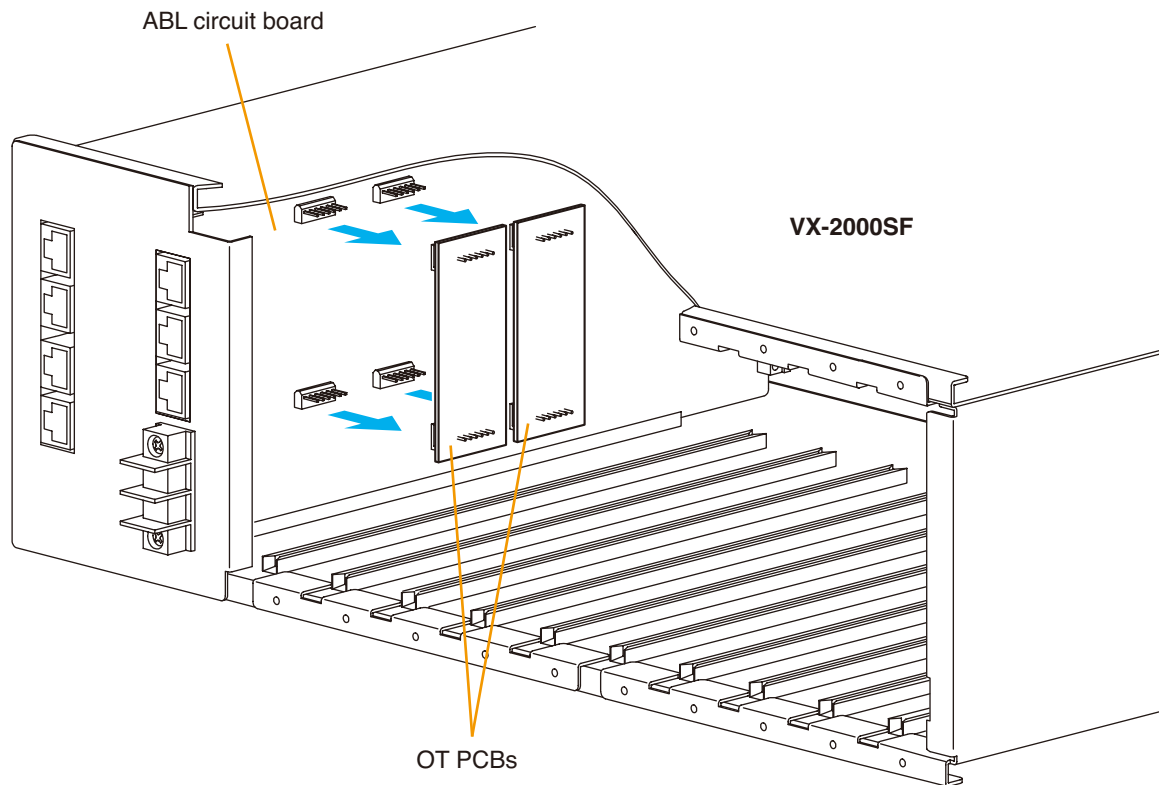

**Step 3.** Cut the jumper wires installed on each transformer board.  
(4 jumpers SJP1401 - SJP1404 on each OT PCB.)

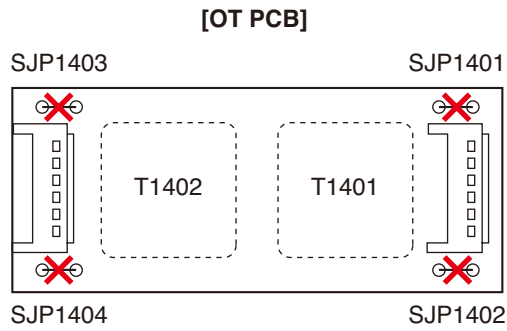

**Step 4.** Solder the IT-450 transformers to locations T1401 and T1402 on each OT PCB.

**Step 5.** Fit both OT PCBs back into place.

**Step 6.** Replace the removed modules and blank panels.

### 3.3 Changing the VX-200SZ's ATT CTRL Output to Photocoupler Type

The ATT CTRL output of the VX-200SZ Impedance Detection Module can be converted from relay to photocoupler operation. The output is factory-preset for relay operation.

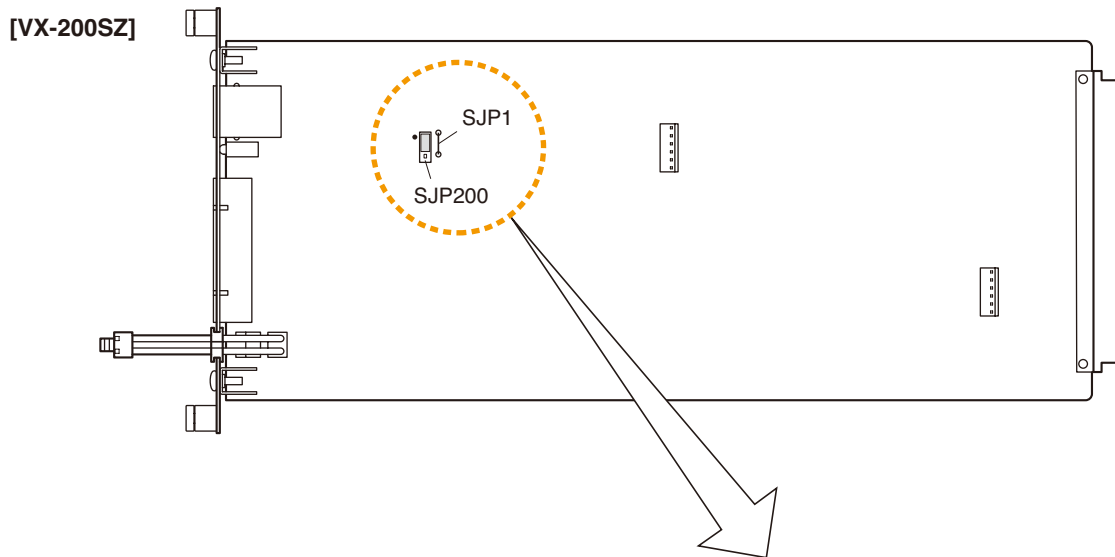

**Step 1.** Cut SJP1 with nippers or other cutters.

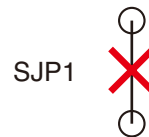

**Step 2.** Remove the short circuit socket (SJP200), then replace it to change its position.

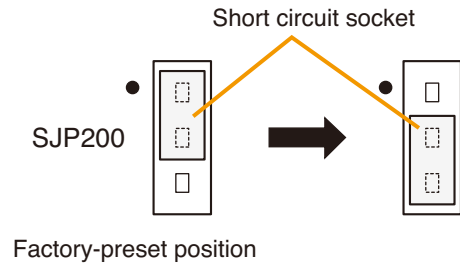

### 3.4. Installing the VX-200SE in the VX-200SZ and VX-200SP

- A 9-band, single-channel equaliser function can be added by installing the VX-200SE Equaliser Card in the VX-200SZ Impedance Detection Module or the VX-200SP Pilot Tone Detection Module.
- In the PC software settings, "EQ" must be set to ON for the VX-200SZ and the VX-200SP in which the VX-200SE is installed. For details, refer to [p. 7-14](#).
- Use the PC software to perform equaliser setting. For details, refer to [p. 7-37](#).

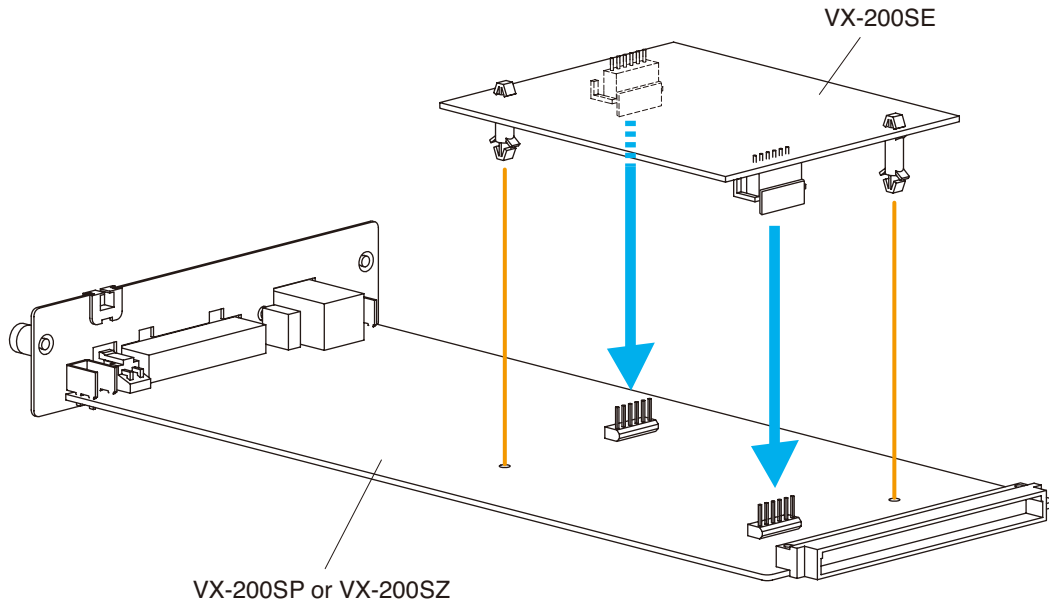



### 3.5. Changing the VX-200SI's Logic

The logic ("make" or "break" signal activation) of the CTRL IN terminal can be changed by the DIP switch on the VX-200SI circuit board.

**[Logic change switch position]**

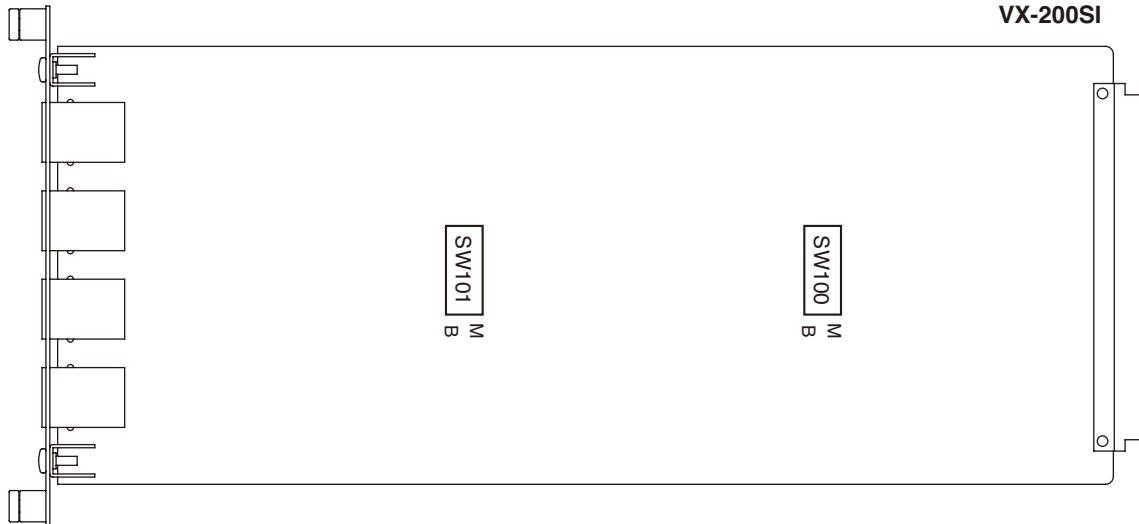

SW100: Used to switch the logic of CTRL IN terminals 1 – 8.  
Switches 1 – 8 correspond to CTRL IN terminals 1 – 8.

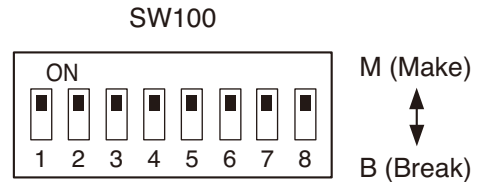

SW101: Used to switch the logic of CTRL IN terminals 9 – 16.  
Switches 1 – 8 correspond to CTRL IN terminals 9 – 16.

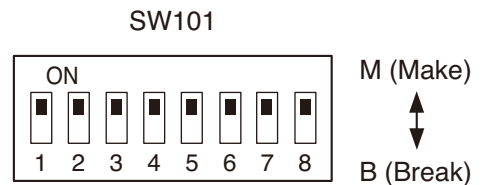

- The logic can be individually changed for each of CTRL IN terminals 1 – 16. To change, set the switch corresponding to the desired CTRL IN terminal to the M (Make) or B (Break) side.
- All switches are factory-preset to the M (Make) side.

### 3.6. Insulating the VX-200SI

The VX-200SI's CTRL IN terminals 1 – 4 can be insulated by performing the following settings to be powered from external equipment.

**Note**

The failure detection function will not work on the CTRL IN channels for which "Insulation setting" has been performed.

**[Insulation setting jumper position]**

Below are the jumpers' factory-preset "Non-insulation" settings.

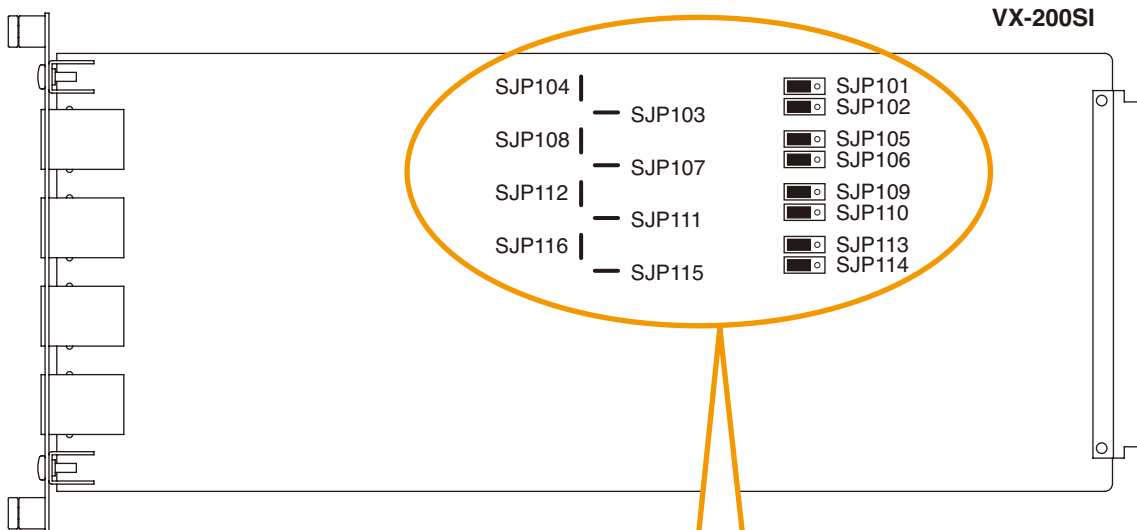

**[SJP101 – SJP116 jumper settings]**

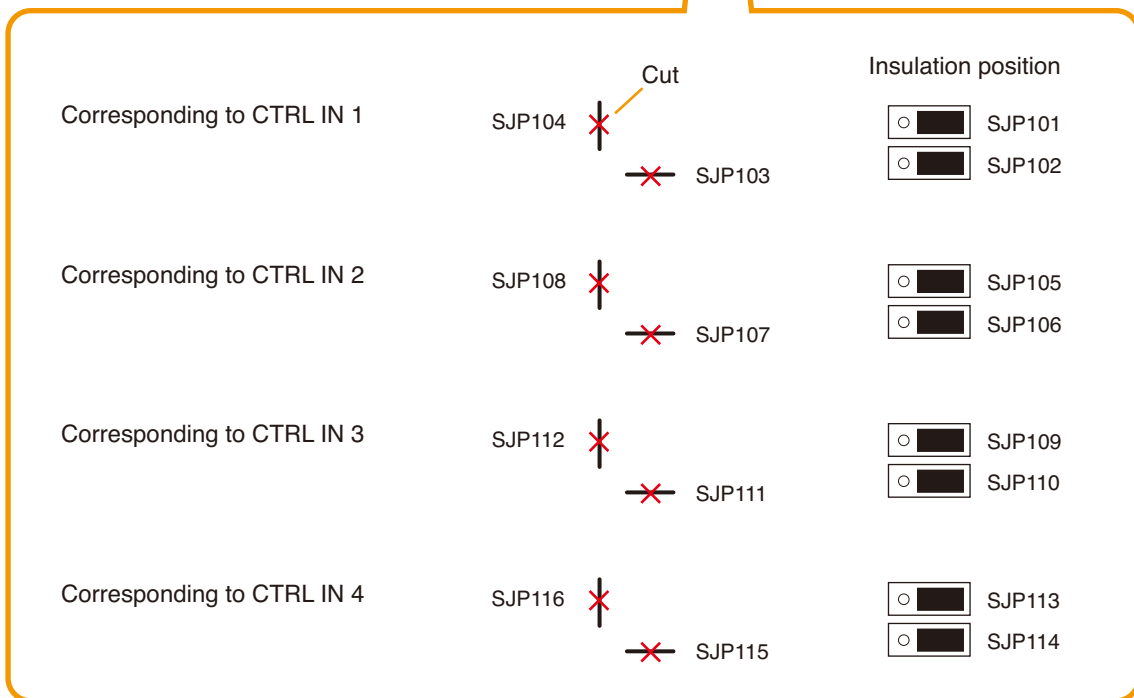

Each of the CTRL IN terminals can be individually set to "Insulation."

To do so, be sure to set 2 jumper plugs and 2 jumpers for each CTRL IN terminal; switch the SJP101 and 102 to the right-hand position and cut the SJP103 and 104 for the CTRL IN 1, likewise SJP105 – 108 for the CTRL IN 2, SJP109 – 112 for the CTRL IN 3, and SJP113 – 116 for the CTRL IN 4.

### 3.7. Installing Modules (VX-200SZ, VX-200SP, VX-200SI, and VX-200SO) in the VX-2000SF Frame

#### Notes

- The slot number and module type to be installed must be identical to those designated by the PC software.
- Cover idle slots with the supplied blank panels to prevent dust from getting into the equipment.

**Step 1.** Align the module with the rails inside the VX-2000SF Frame, then push the module in to plug its connector strip securely into the VX-2000SF's internal connector.

**Step 2.** Tighten both the top and bottom screws.

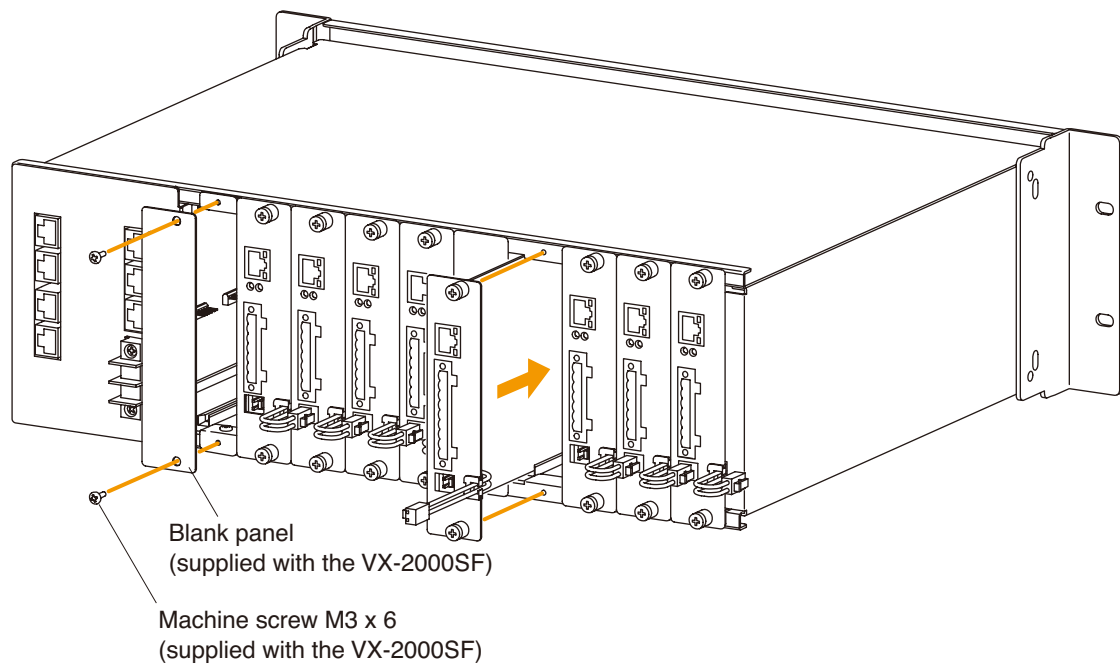

## 4. VP-2064, VP-2122, VP-2241 AND VP-2421 POWER AMPLIFIERS

### 4.1. Removing the VP Power Amplifier's Top Panel

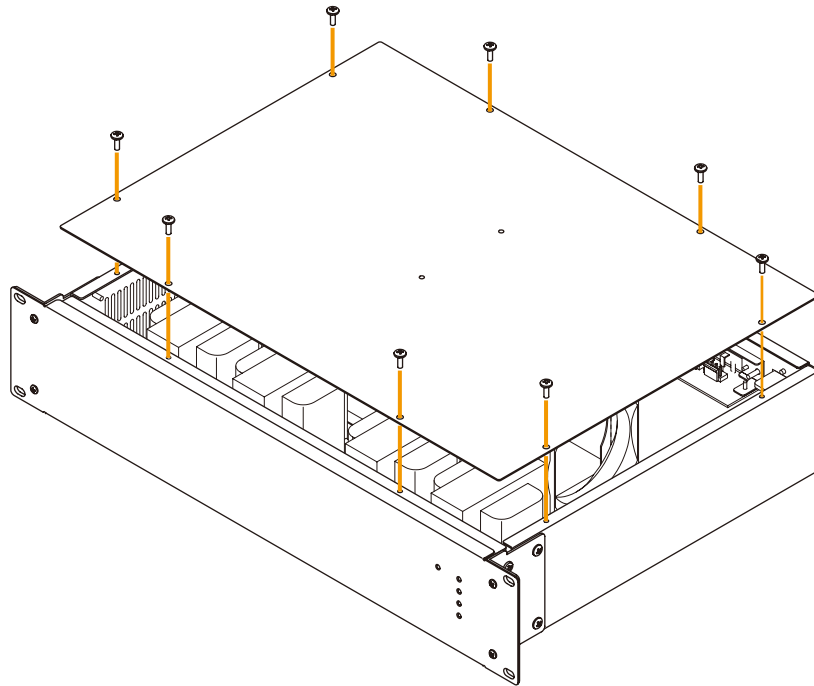

### 4.2. Changing the Speaker Line Voltage

The speaker line voltage of the VP-2064, VP-2122, VP-2241 and VP-2421 is factory-preset to 100 V, however this can be changed to 50 V or 70 V by following the procedures below.

#### Note

The speaker line failure detection functions are designed to perform on a 100-volt line of speaker. For the methods using a 70- or 50-volt line, please consult your TOA dealer.

**Step 1.** Remove the top panel referring to the above figure.

**Step 2.** Remove the connectors.

[VP-2064 Connector position]

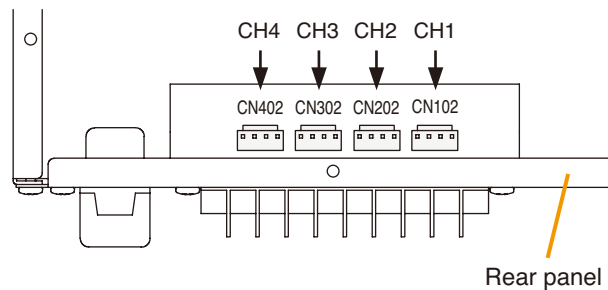

[VP-2122 Connector position]

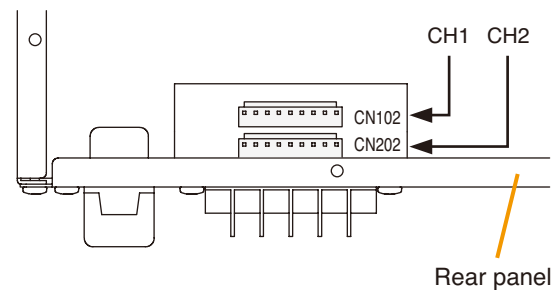

[VP-2241 Connector position]

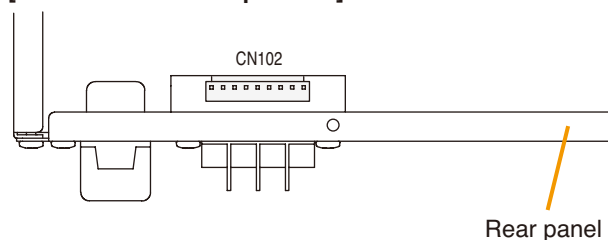

[VP-2421 Connector position]

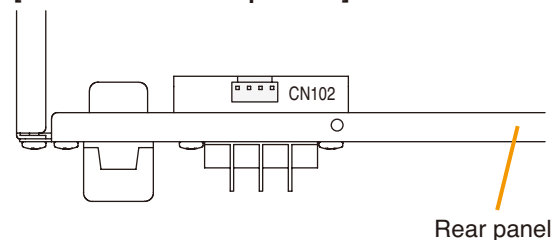

**[Channel-to-connector relationship]**

Model No.	VP-2064	VP-2122	VP-2241	VP-2421
Channel 1	CN102	CN102	CN102	CN102
Channel 2	CN202	CN202	—	—
Channel 3	CN302	—	—	—
Channel 4	CN402	—	—	—

**Step 3.** Change wiring.

Disconnect a line and exchange it with the corresponding line. Refer to the figure below when removing.

To change to 50 V, exchange the Pin No. 1 line (white) with the Pin No. 3 line (blue).

To change to 70 V, exchange the Pin No. 1 line (white) with the Pin No. 2 line (purple).

**[VP-2064/VP-2421 Connector Pin Assignment]**

Speaker line voltage	Pin No.			
	1	2	3	4
100 V (factory-preset voltage)	White	Purple	Blue	Black
70 V	Purple	White	Blue	Black
50 V	Blue	Purple	White	Black

**[VP-2122/VP-2241 Connector Pin Assignment]**

Speaker line voltage	Pin No.								
	1	2	3	4	5	6	7	8	9
100 V (factory-preset voltage)	White	Purple	Blue	Green	Yellow	Orange	Red	Brown	Black
70 V	Purple	White	Blue	Green	Yellow	Orange	Red	Brown	Black
50 V	Blue	Purple	White	Green	Yellow	Orange	Red	Brown	Black

**[Speaker line voltage/impedance]**

Speaker line voltage	VP-2064	VP-2122	VP-2241	VP-2421
100 V	167 Ω	83 Ω	41 Ω	24 Ω
70 V	83 Ω	41 Ω	21 Ω	12 Ω
50 V	41 Ω	21 Ω	10 Ω	6 Ω

**[How to remove cables from connector]**

Pull out the cable pressing the lock spring with a pointed object like tweezers as shown below.

Pull out the cable.

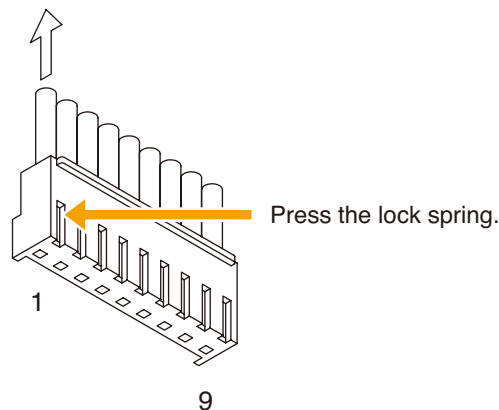

**Step 4.** Insert the connectors back into their original positions on the circuit board.

**Step 5.** Replace the top panel.

### 4.3. Installing the VP-200VX Power Amplifier Input Module in the VP Power Amplifiers

**Step 1.** Remove the top panel.

Refer to p. 8-34 "4.1. Removing the VP Power Amplifier's Top Panel" for removal procedures.

**Step 2.** Using nippers, clip out 4 connecting sections and the plate over the VP-200VX mounting location on the power amplifier's rear panel.

**Notes**

- CH1 is not covered with a plate.
- Remove only the plate of the channel to be used.

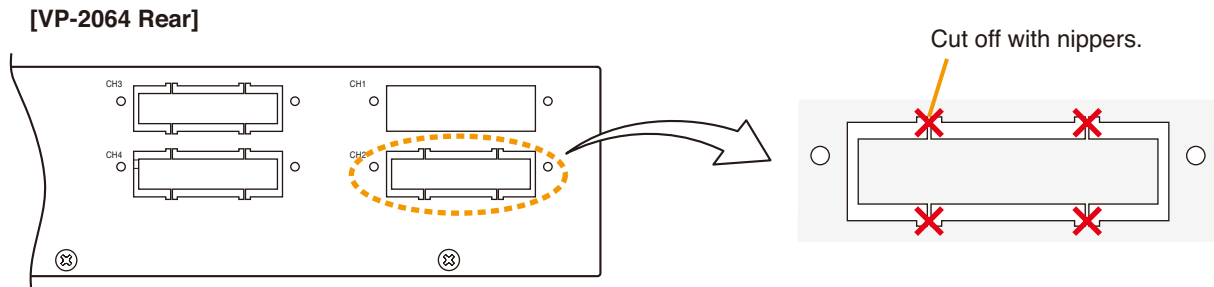

**Step 3.** Unscrew the VP-200VX's panel.

**Step 4.** Mount the VP-200VX module.

Attach the VP-200VX 's panel to the mounting location and the VP-200VX unit to the back of the mounting location, then secure them to the amplifier using the screws removed in **Step 3**.

**Notes**

- Perform installation for lower mounting locations (CH2 and CH4) first.
- Mount the VP-200VX with its circuit board components faced down.

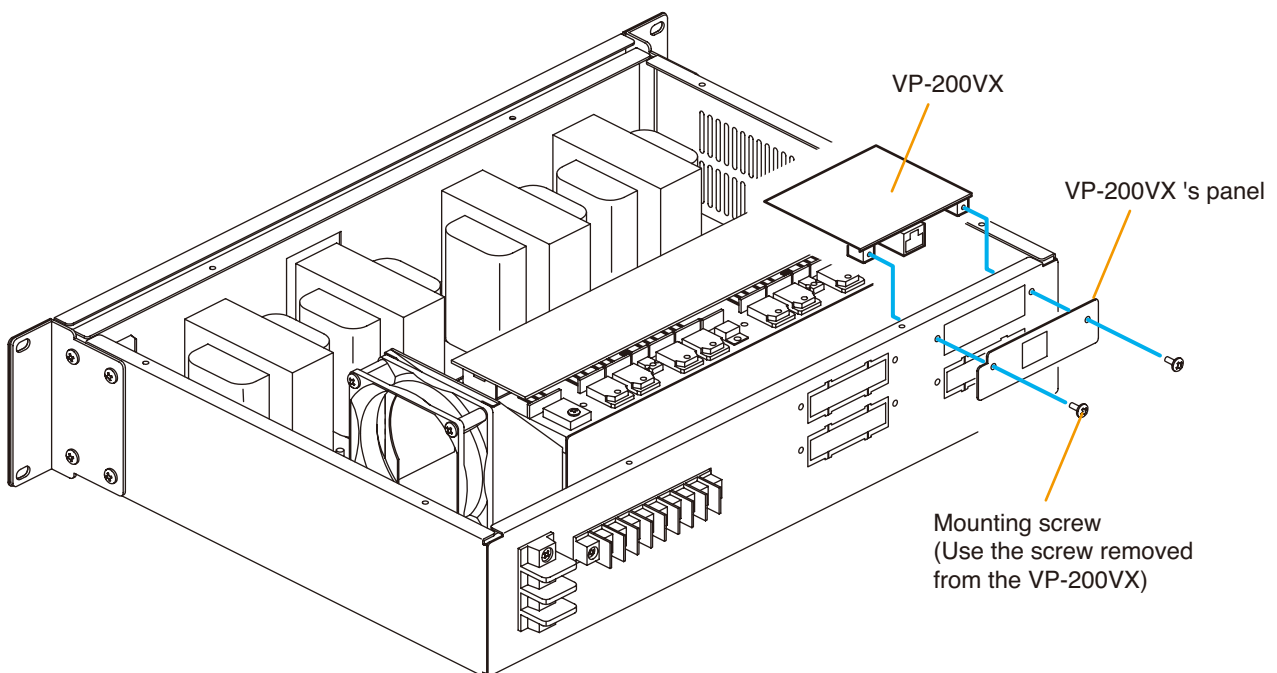

**Step 4.** Plug the VP-200VX's connector into the corresponding channel connector on the circuit board inside the amplifier.

[VP-2064 Connector position]

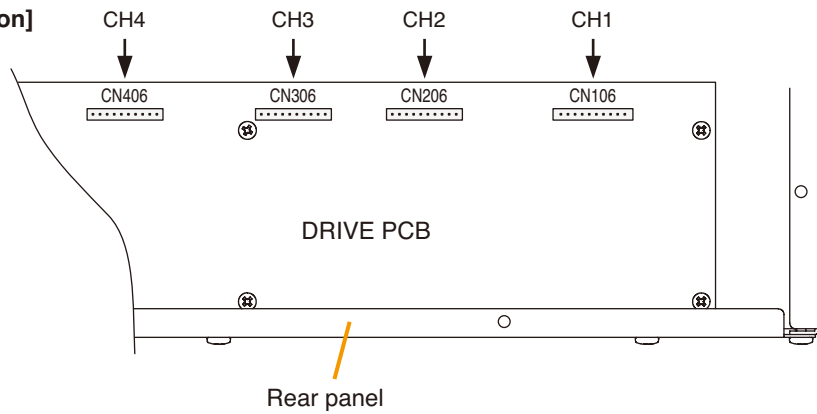

[VP-2122 Connector position]

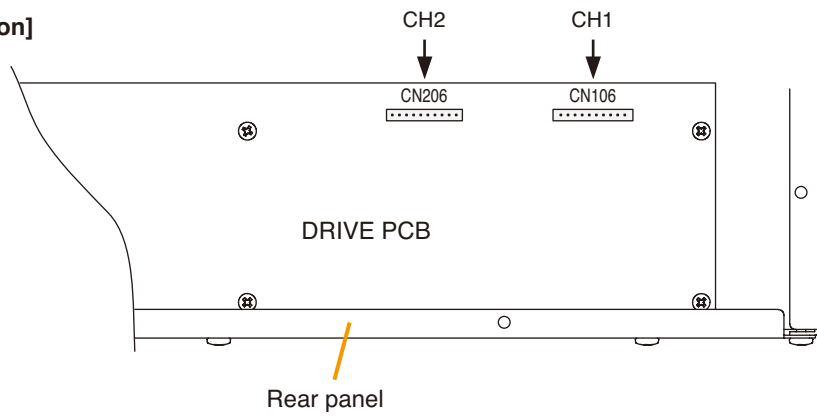

[VP-2241/2421 Connector position]

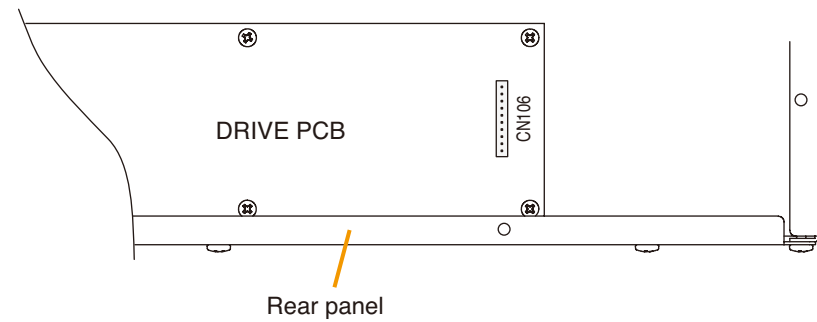

[Channel-to-connector relationship]

Model No.	VP-2064	VP-2122	VP-2241	VP-2421
Channel 1	CN106	CN106	CN106	CN106
Channel 2	CN206	CN206	—	—
Channel 3	CN306	—	—	—
Channel 4	CN406	—	—	—

**Step 5.** After mounting is completed for all required channels, replace the top panel.

#### 4.4. Ground Lifting Using the VP-200VX Power Amplifier Input Module

When operating the system, hum noise may be generated by a ground loop accidentally created in the system. The ground loop can be cut off with the Ground Lift jumper connector setting on the VP-200VX board.

### WARNING

To access the Ground Lift jumper connector, take out the internal VP-200X from the VP amplifier. Make sure that the system power is switched OFF before starting the work.

For procedures regarding switching off the system power, refer to the Instruction Manual attached to the VX-2000DS/3000DS.

**Step 1.** Remove the VP amplifier's top panel.

Refer to [p. 8-34](#) "Removing the VP Power Amplifier's Top Panel."

**Step 2.** Take out the VP-200VX.

**Step 3.** Unplug the jumper socket and plug it to the LIFT position on the VP-200VX board as shown below.

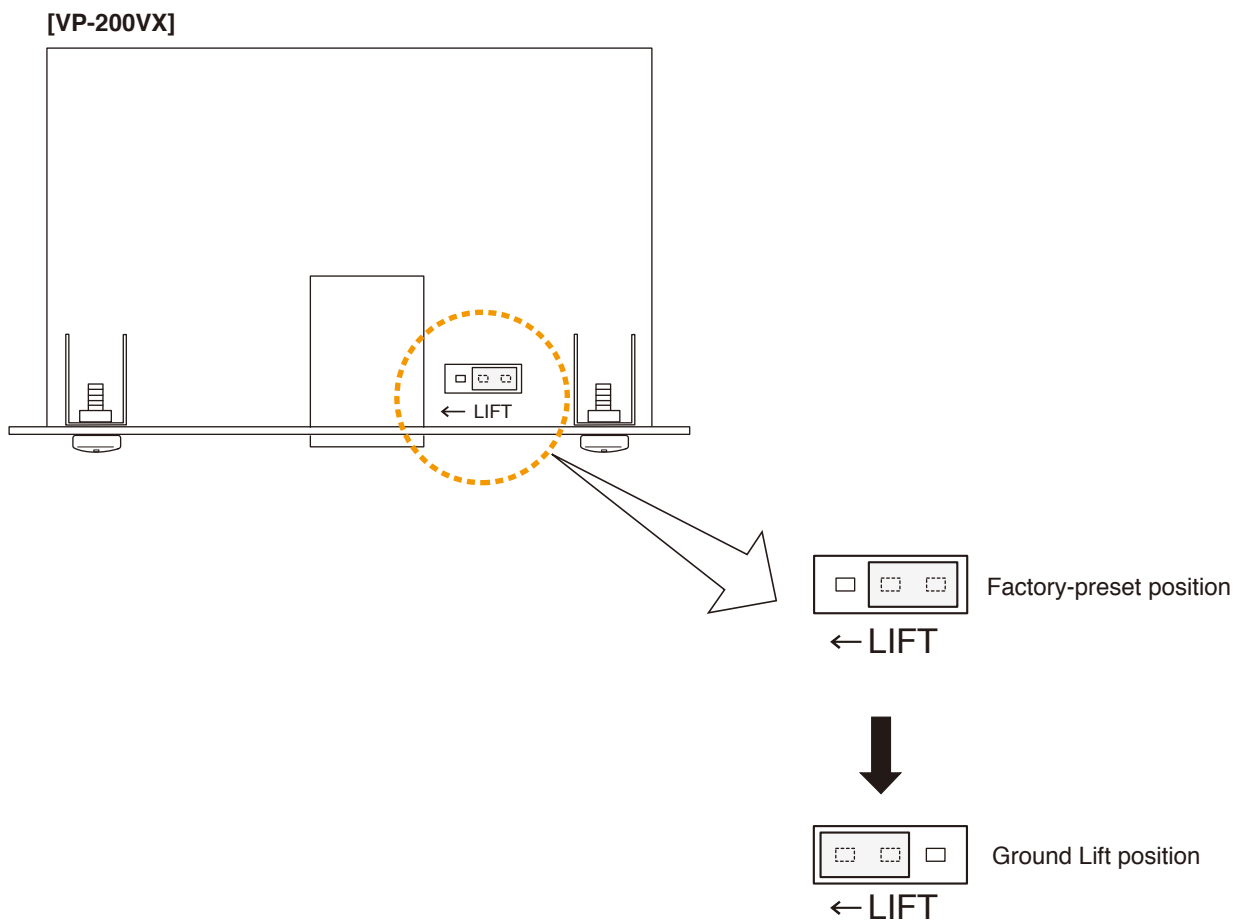

**Step 4.** Fit the VP-200VX back into place.

**Step 5.** Replace the top panel.



## 4.5. Replacing the Blade Fuse

When the internal blade fuse blew, replace it with new one following the procedures below.

### WARNING

Be sure to switch off the system power before accessing to the internal fuse for replacement. For the method to switch off the power, refer to the Instruction Manual attached to the VX-2000DS/3000DS.

**Step 1.** Remove the VP amplifier's top panel.  
Refer to [p. 8-34](#) "Removing the VP Power Amplifier's Top Panel."

**Step 2.** Replace the Blade fuse.

Capacity

VP-2064: Blade-Type Fuse 7.5 A

VP-2122: Blade-Type Fuse 15 A

VP-2241: Blade-Type Fuse 25 A

VP-2421: Blade-Type Fuse 35 A

[VP-2064 Blade fuse position]

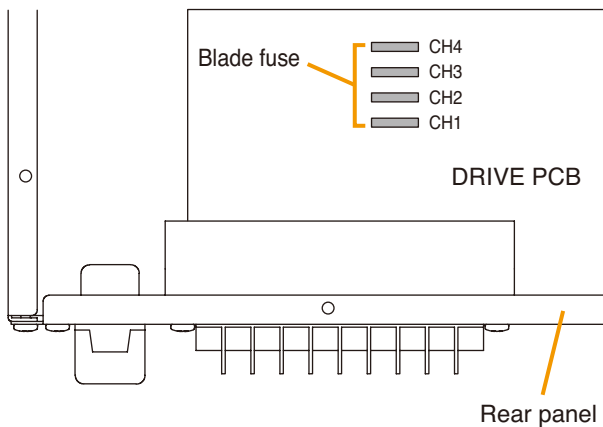

[VP-2122 Blade fuse position]

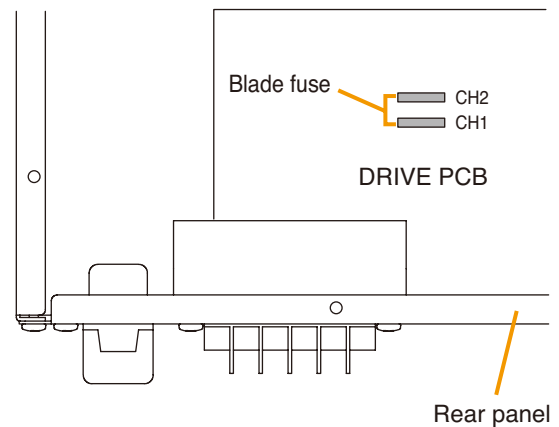

[VP-2241/-2421 Blade fuse position]

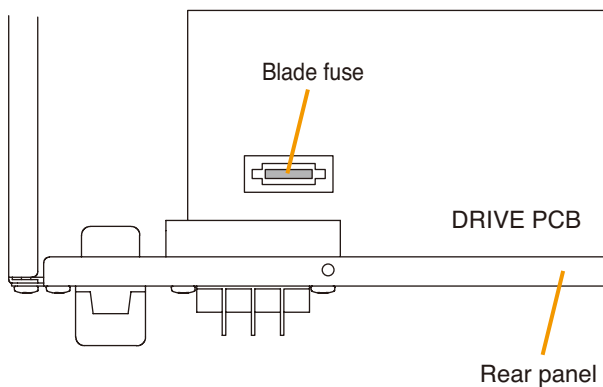

### Note

After completing the replacement of the fuse, remove the cause of fuse blowout before turning on the system power.

## 5. VP-3154, VP-3304 AND VP-3504 POWER AMPLIFIERS

This section describes the following work procedures inside the unit: Speaker line voltage change, ground lifting, BGM input sensitivity setting, and fuse replacement.

### WARNING

Switch off the system power before starting the work in this section as there is high voltage inside the unit which may cause electric shock.

For procedures to switch off the system power, refer to the instruction manual attached to the VX-3000DS.

### 5.1. Changing the Speaker Line Voltage

The speaker line voltage of the VP-3154, VP-3304, and VP-3504 is factory-preset to 100 V, however, this can be changed to 50 V or 70 V following the procedures below.

#### Note

The speaker line failure detection functions are designed to perform on a 100-volt line of speaker. For the methods using a 70- or 50-volt line, please consult your TOA dealer.

**Step 1.** Remove the top panel.

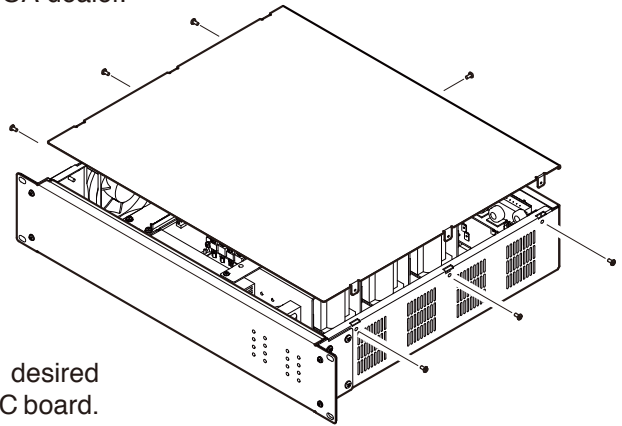

**Step 2.** Shift the speaker line voltage selector to the desired voltage position on the corresponding channel's PC board.

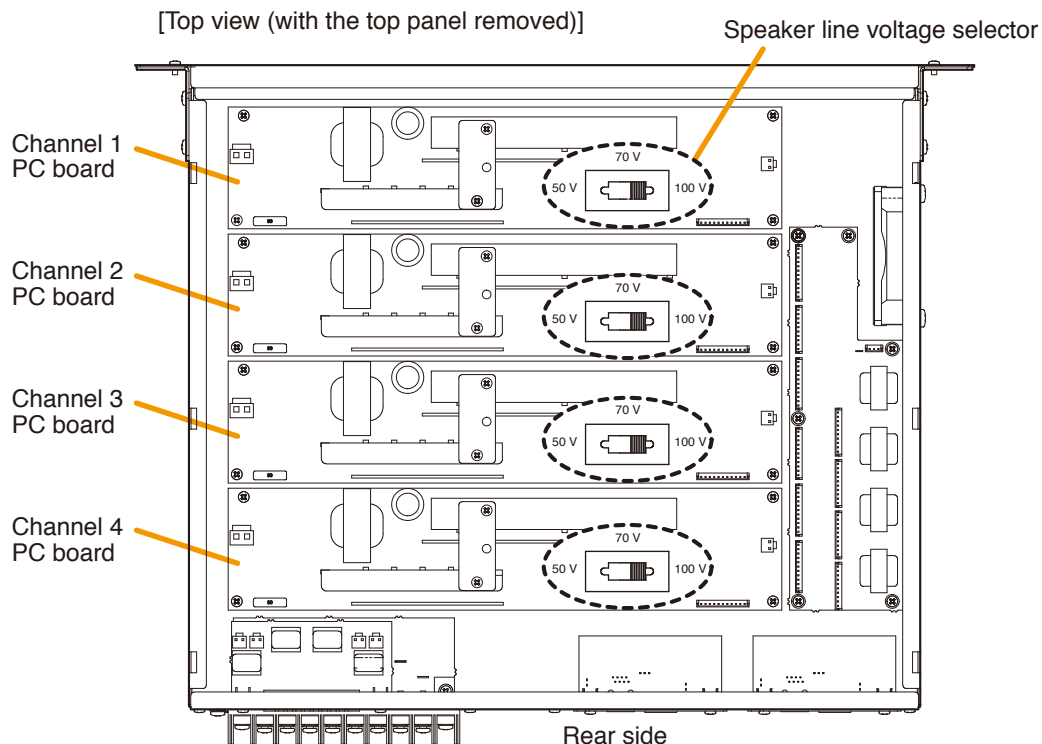

**Step 3.** Replace the top panel.

## 5.2. Ground Lifting

Hum noise may be generated by a ground loop accidentally created through the PA link's audio input. In this case, the ground loop can be cut by setting the ground lift, which can be performed on the pc board of PA link/BGM input board.

Amplifier's rear

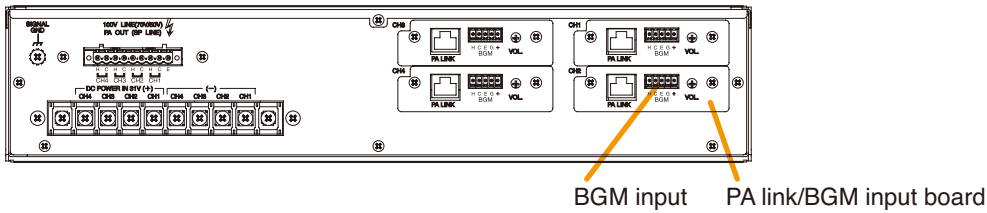

**Step 1.** Remove the top panel. (See Step 1 on p. 8-40.)

**Step 2.** Take out the PA link/BGM input board to be set for ground lift.

Remove 2 screws at the corresponding channel's board on the amplifier's rear while holding the internal PC board as show below.

The figure below shows an example of removing channel 1's board.

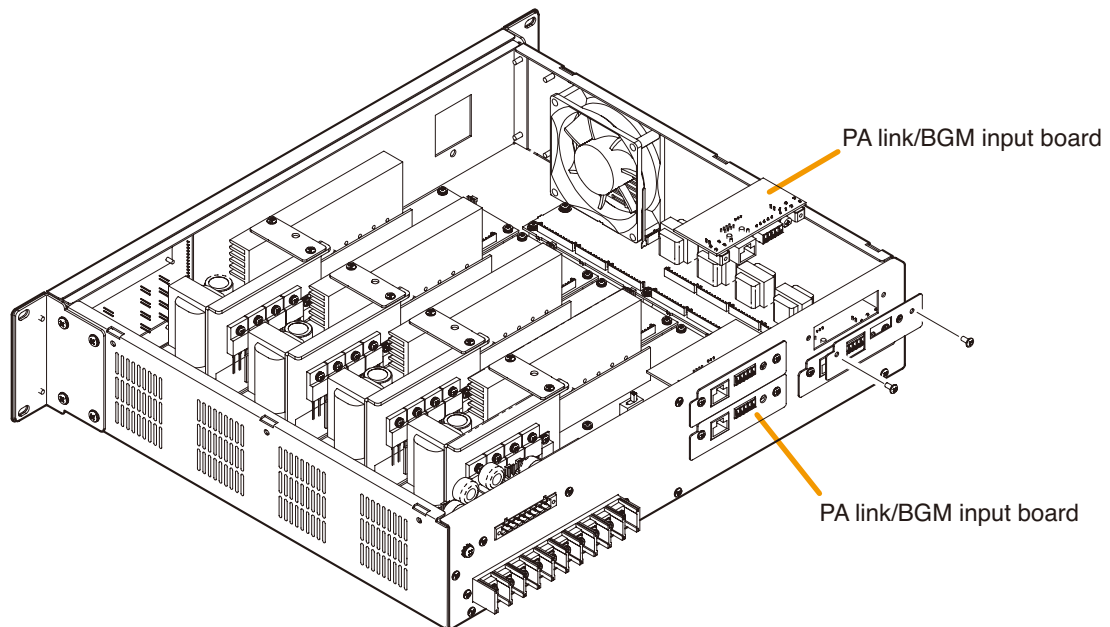

**Step 3.** Cut the jumper J2 on the pc board.

Viewed from the parts mounting side

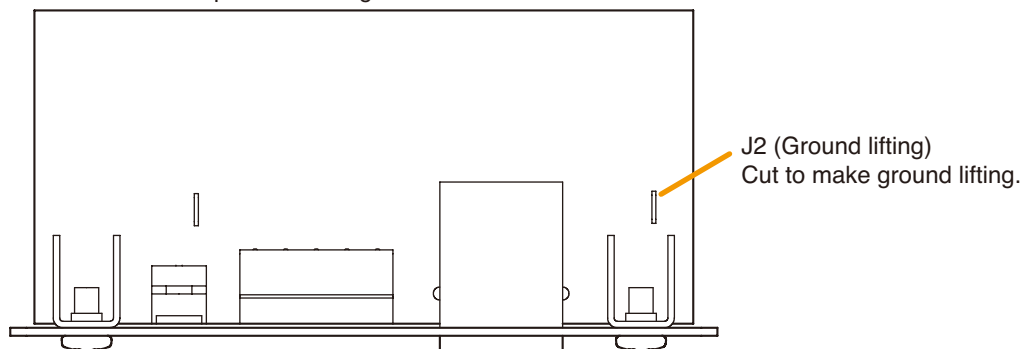

**Step 4.** Replace the PA link/BGM input board and the top panel in the reverse procedures of removal.

### 5.3. BGM Input Sensitivity Setting

The BGM input sensitivity can be changed from  $-10\text{ dB}^*$  (factory-preset) to  $0\text{ dB}^*$ .

Modification can be performed on the pc board of PA link/BGM input board.

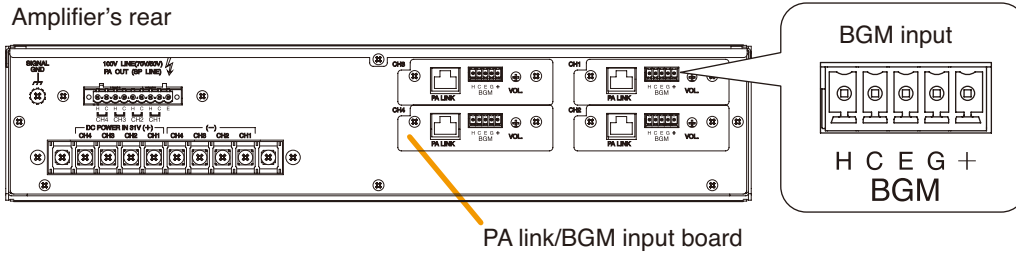

**Step 1.** Remove the top panel. (See Step 1 on [p. 8-40](#).)

**Step 2.** Take out the PA link/BGM input board to be set. (See Step 2 on [p. 8-41](#).)

**Step 3.** Cut the jumper J1.

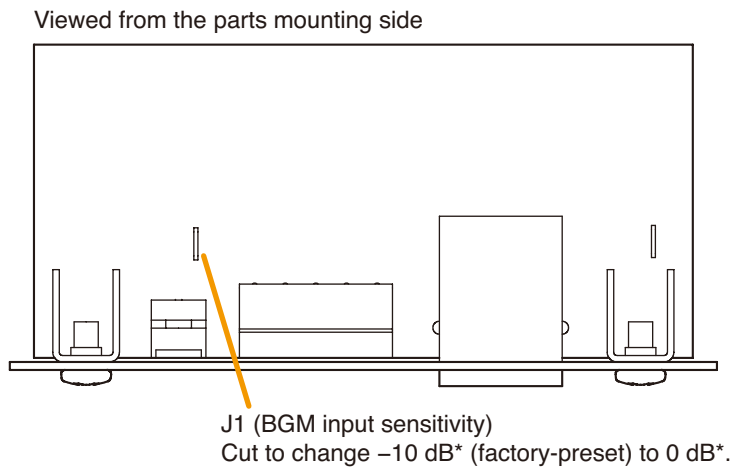

**Step 4.** Replace the PA link/BGM input board and the top panel in the reverse procedures of removal.

\*  $0\text{ dB} = 1\text{ V}$

## 5.4. Replacing the Fuse

When a fuse has blown, the corresponding channel status indicator on the unit's front panel goes out. In this case, replace the fuse mounted on the Channel pc board inside the unit.

**Step 1.** Remove the top panel.

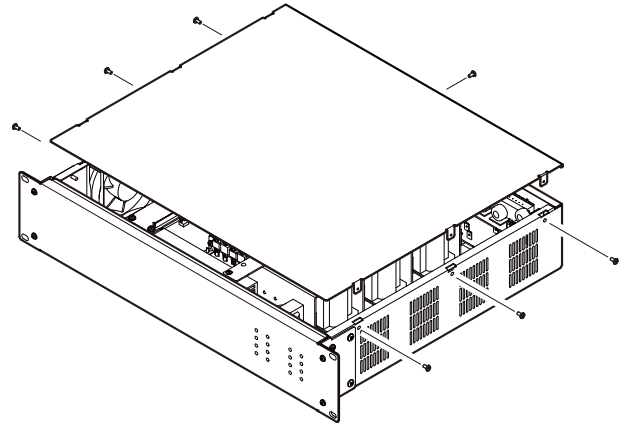

**Step 2.** Replace the blown fuse on the corresponding Channel pc board with a new one.

### Note

When replacing the fuse, be sure to use the same Blade-type of fuse, of which rating differs depending on the models as follows.

VP-3504: 30 A

VP-3304: 20 A

VP-3154: 10 A

[Top view (with the top panel removed)]

The figure below shows the VP-3504.

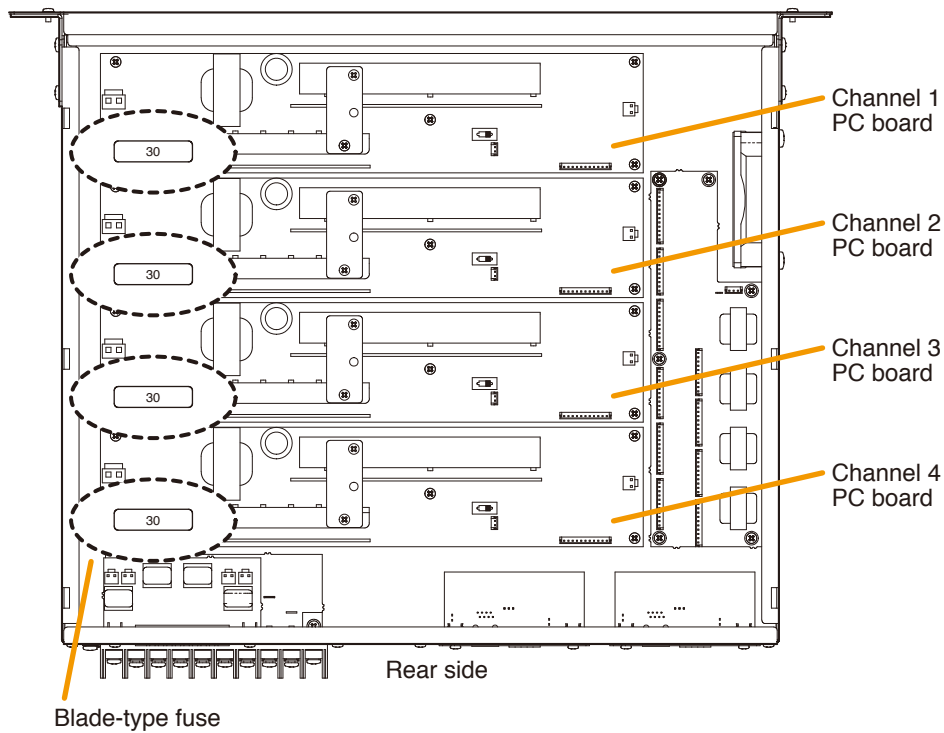

**Step 3.** Replace the top panel.

## 6. RACK MOUNTING

Observing the following precautions, mount the equipment in the rack.

- It is recommended that a blower unit be installed at the uppermost position for efficient exhaust of inner heated air.
- Mount the power amplifier as high as possible in the rack.
- Mount at least 1 perforated panel (1 rack unit size) above and below every 2 power amplifier units.
- Mount a perforated panel above the VX-2000DS to facilitate its internal fuse replacement because fuse can be accessed through the rear most section of the top panel.
- When batteries are installed in the rack, place them directly below the VX-2000DS so that they can perform temperature compensation for the charging voltage. In this case, use a perforated panel in front of the rack to avoid excessive temperature rise around the batteries. For installing batteries, refer to the Instruction Manual attached to the VX-2000DS.

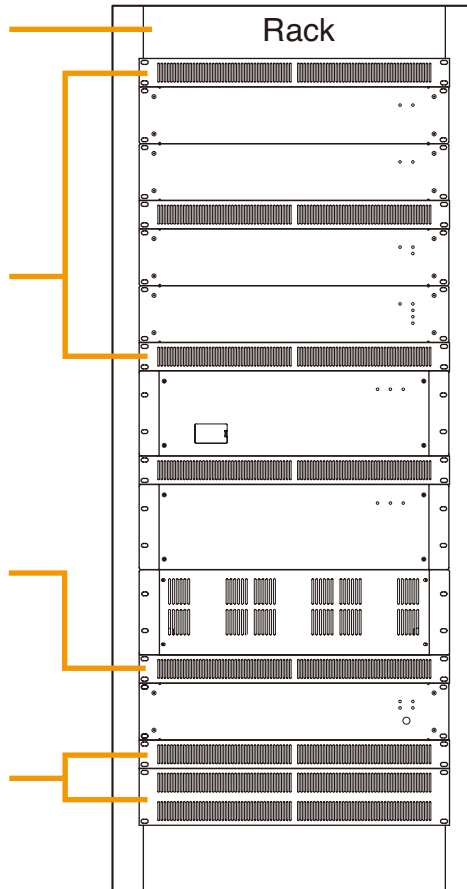

1	PF-013B
2	VP-2421
3	VP-2421
4	VP-2241
5	VP-2241
6	PF-013B
7	VP-2122
8	VP-2122
9	VP-2064
10	VP-2064
11	PF-013B
12	VP-2064
13	VX-2000
14	VX-2000
15	PF-013B
16	VX-2000SF
17	VX-2000SF
18	VX-2000SF
19	VX-2000SF
20	VX-2000PF
21	VX-2000PF
22	PF-013B
23	VX-2000DS
24	VX-2000DS
25	PF-013B
26	PF-013B
27	PF-023B

### Notes

- When the amplifiers are installed, the supporting brackets shall be used in the rack to safely mount and securely support the units.
- The perforated panel is recommended in place of space.
- The VX-2000DS, VX-2000PF, and VX-200PS must be installed in the cabinet rack of CR series (models CR-15, CR-22, CR-27, CR-35, CR-40, and CR-44).
- The VX-2000DS and VX-2000PF must be supported by the supporting brackets.
- When the rack is installed in environment with an ambient temperature of more than 30 °C, then the "FAN KIT" must be installed. It can be controlled by a temperature sensor which shall activate the fan at 40 °C or less.



# ***Chapter 9***

---

## **CONNECTIONS**

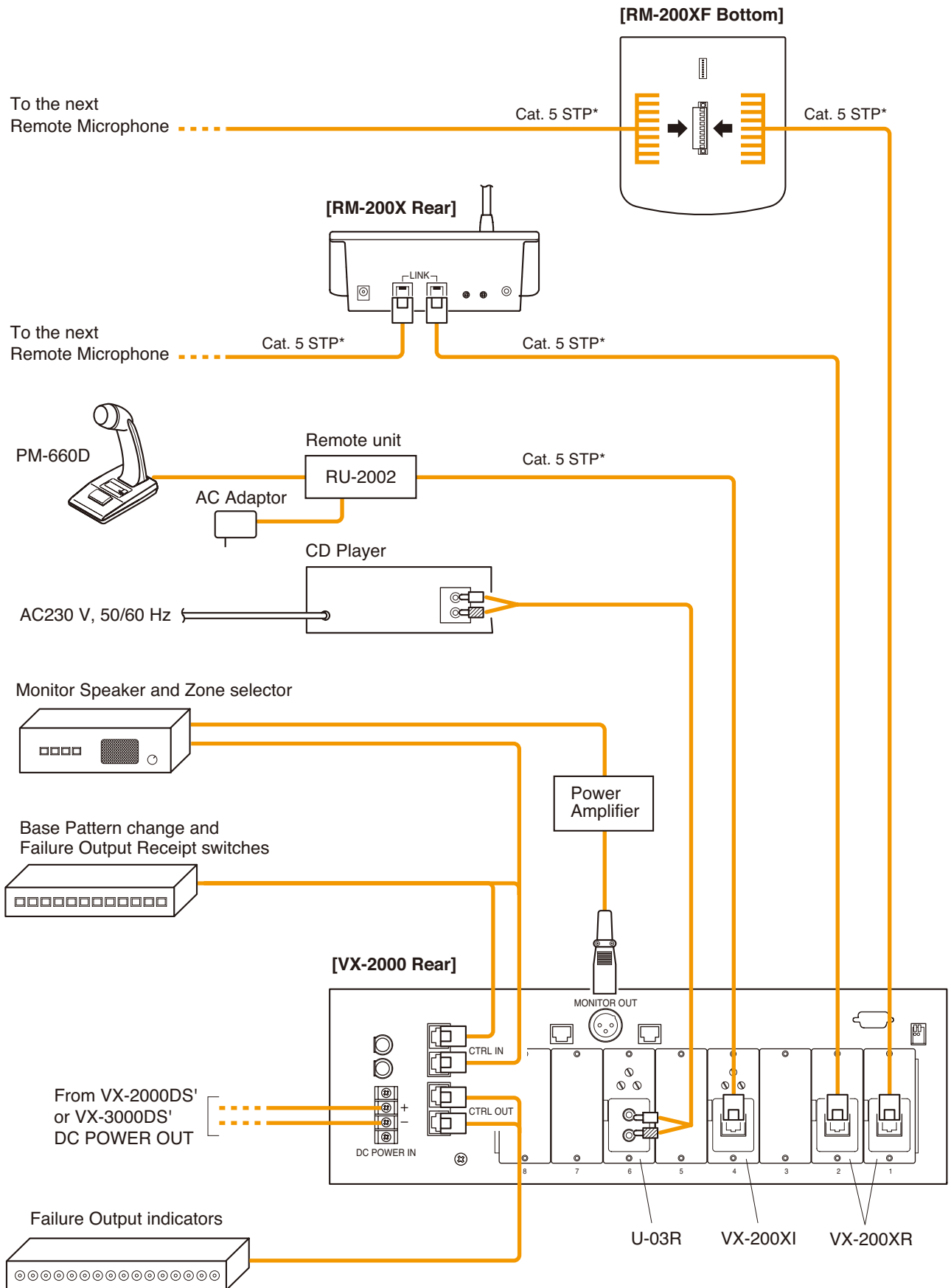
# 1. VX-2000 CONNECTIONS TO REMOTE MICROPHONES AND INPUT SOURCE EQUIPMENT



-  --- RJ45 male connector
-  --- RCA plug
-  --- XLR type female connector

\* TIA/EIA-568A standard Category 5 Shielded Twisted-Pair cable (Abbreviated to "Cat. 5 STP cable.")



## 2. CONNECTIONS BETWEEN VX-2000 AND VX-2000SF

 --- RJ45 male connector

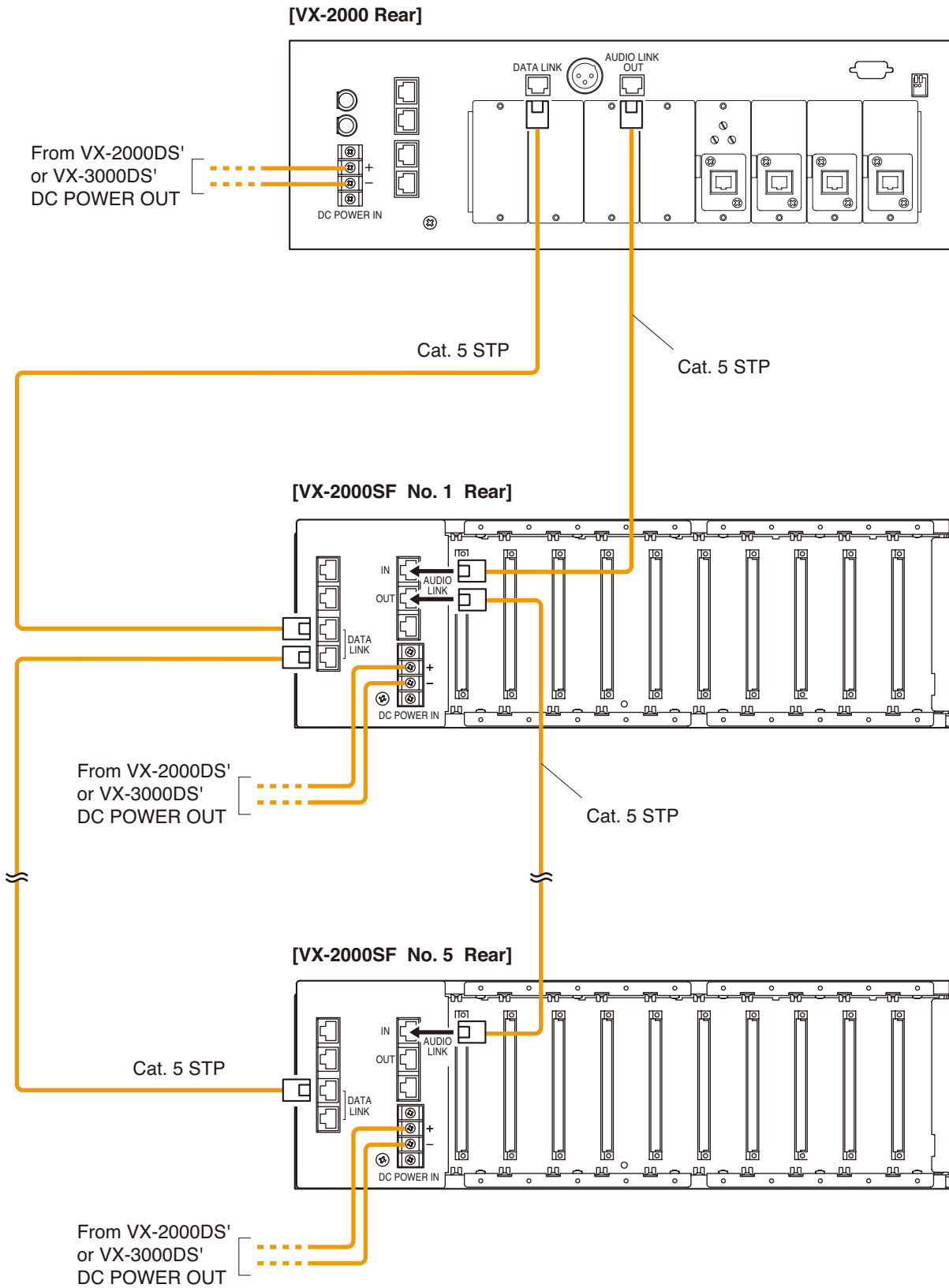

**Note**

Turn ON the terminator of the VX-2000SF connected last using the unit's front-mounted setting DIP switch. When a single VX-2000SF unit is connected, switch its terminator ON. For setting the terminator, refer to [p. 8-26](#).

### 3. SF MODULES (VX-200SP, VX-200SZ, VX-200SI, VX-200SO) CONNECTIONS

#### 3.1. SF Modules Configuration Example

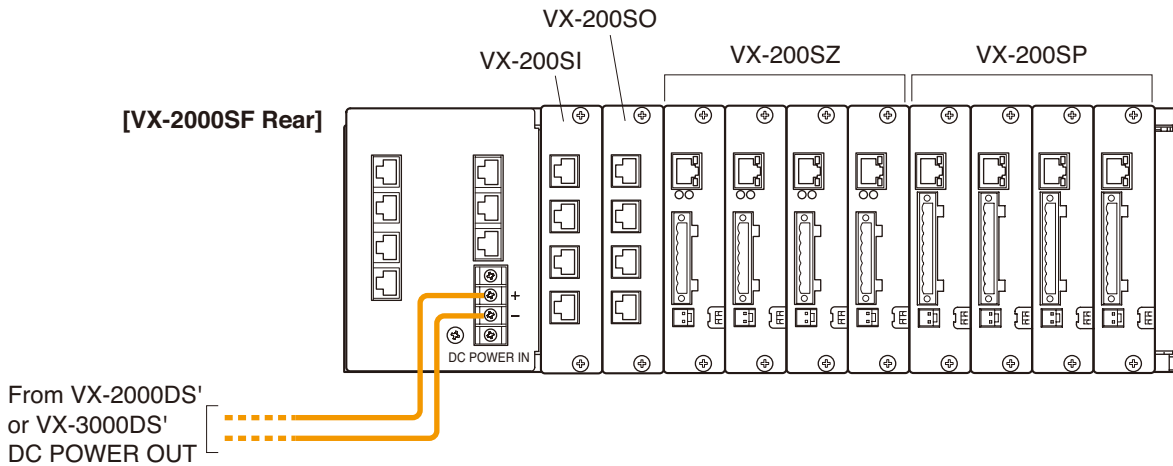

#### 3.2. VX-200SP and VX-200SZ Connection to Power Amplifier and Speakers

[When VP-2122 is used]

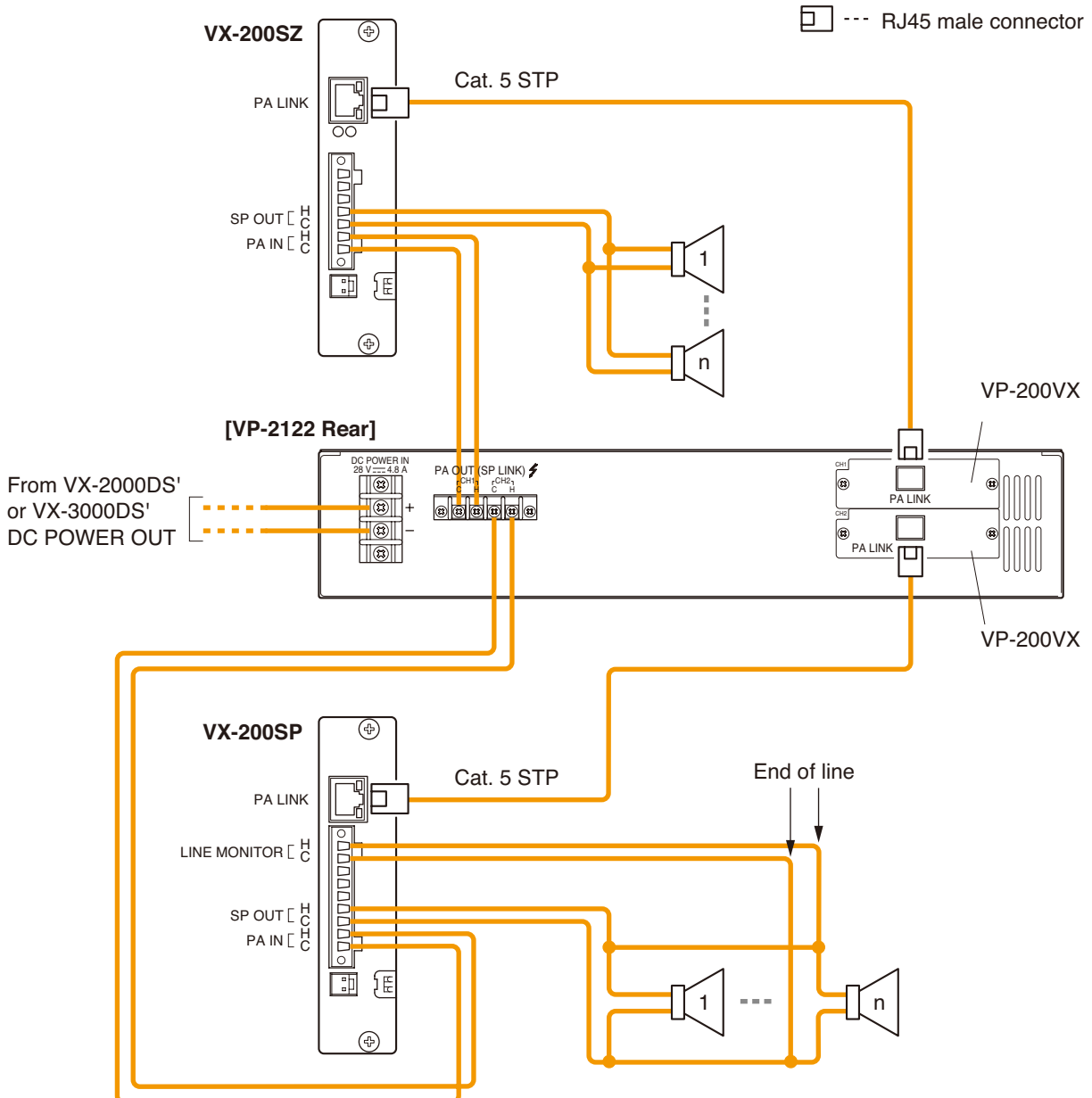

[When VP-3304 is used]

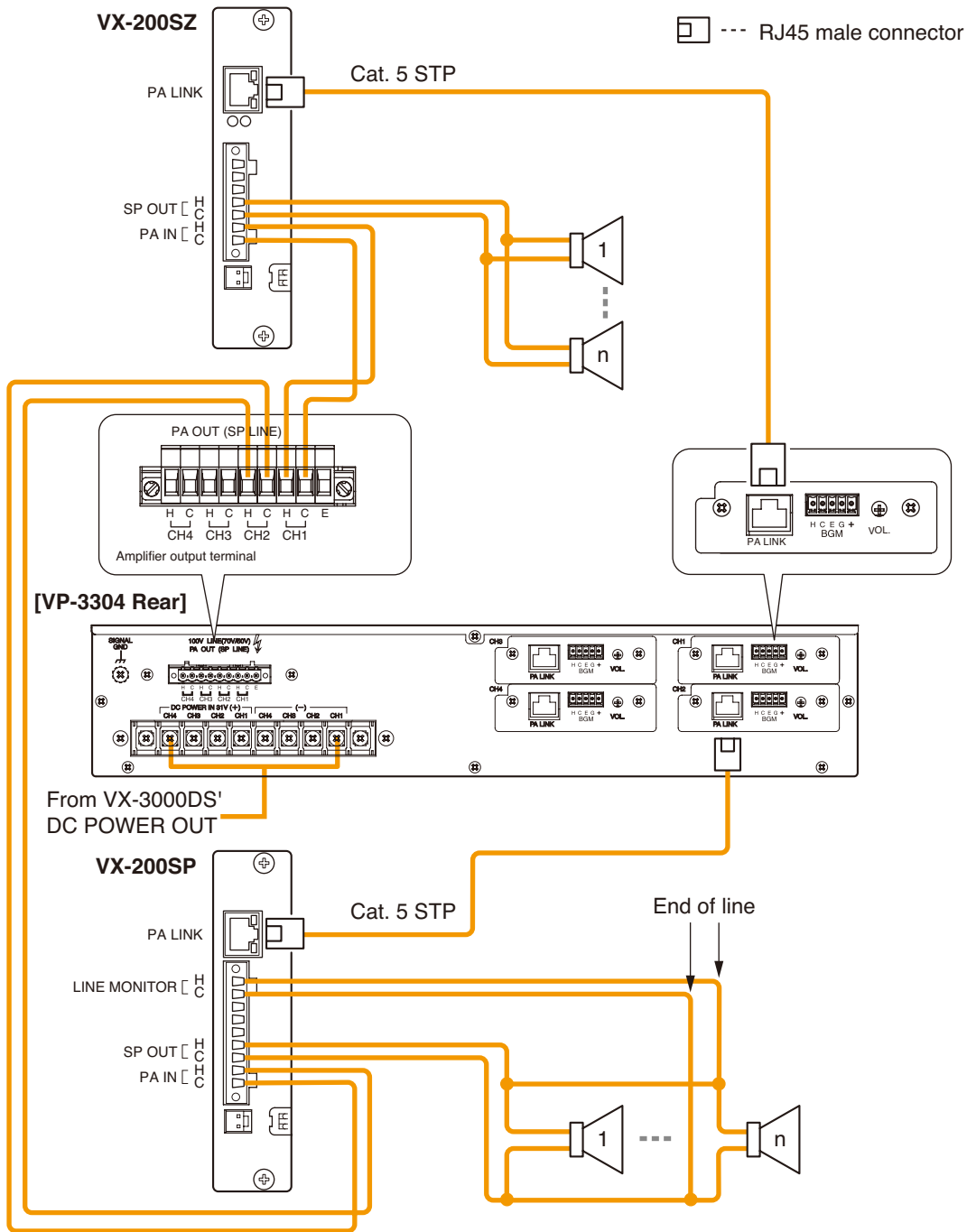

[When VP-3304 is used] (In the case shielded cables are used)

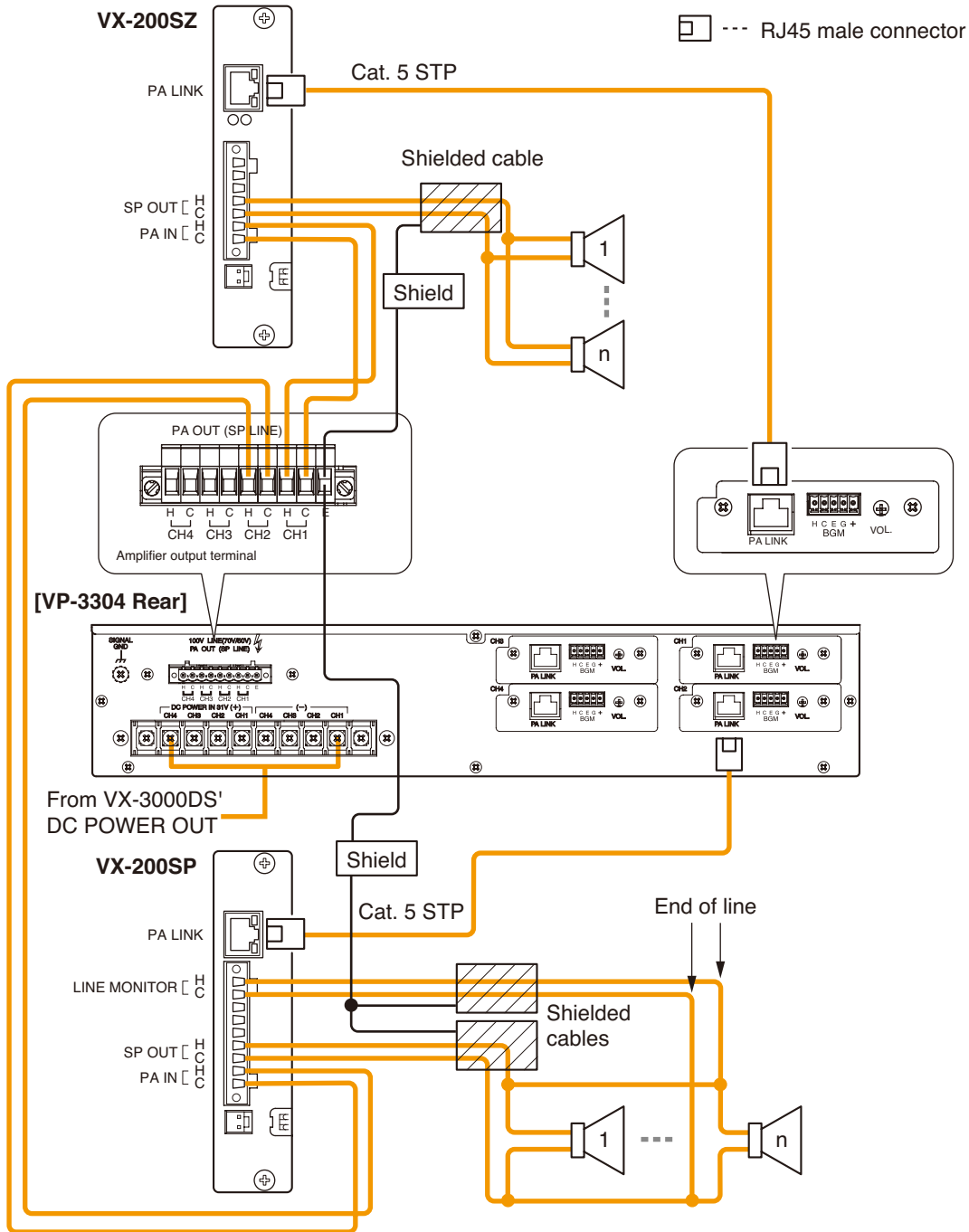

**Note:** Be sure to connect the shield wire of each shielded cable to the VP-3304's "E" terminal.

### 3.3. VX-200SP Connection to External Attenuator

#### 3.3.1. 3-wire system connection

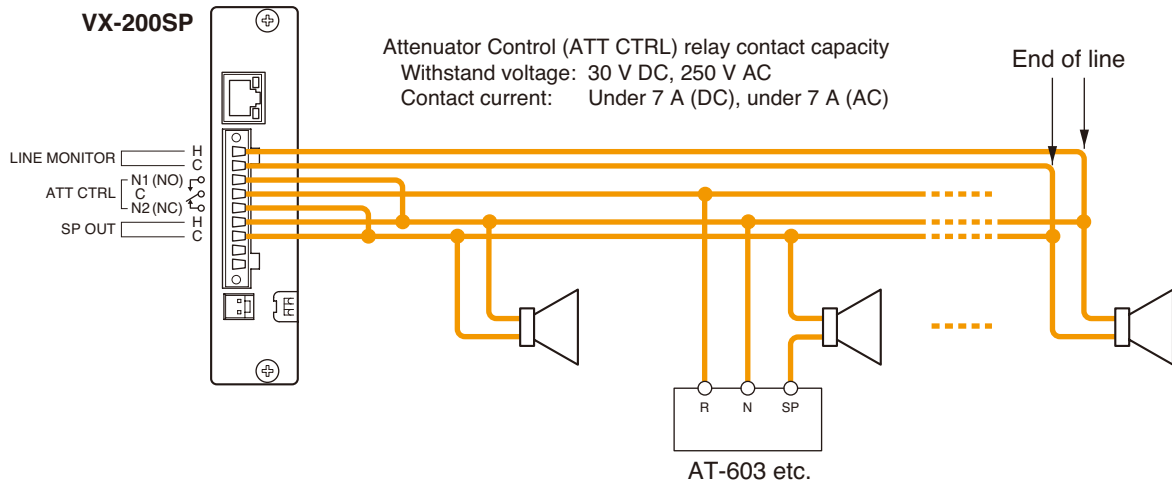

#### 3.3.2. 4-wire system connection

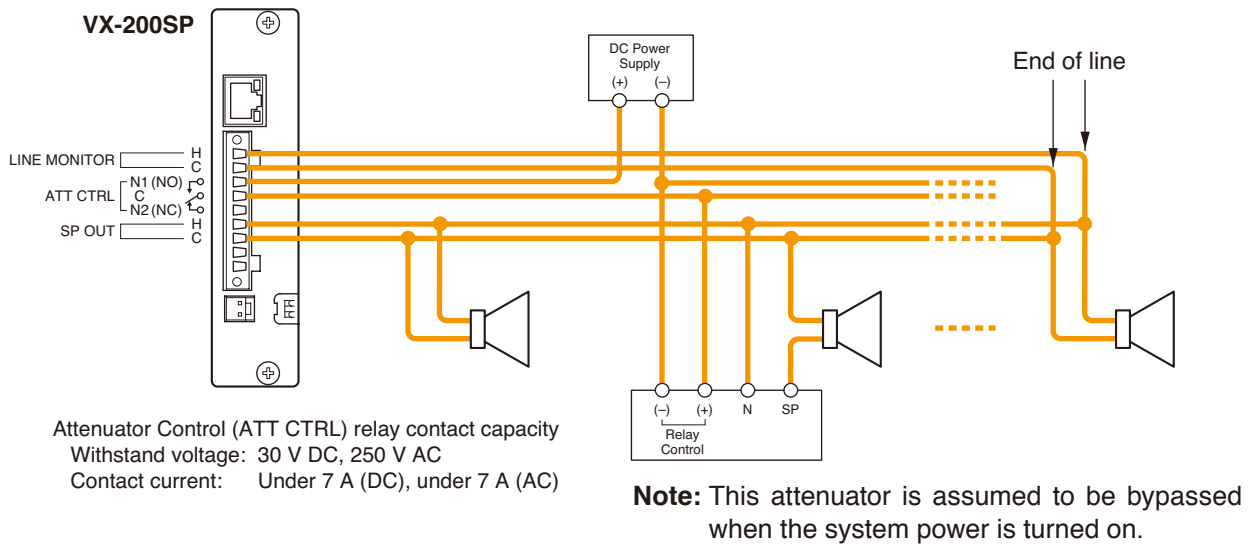

### 3.4. VX-200SZ Connection to External Attenuator

**Note:** Only the external attenuators of 4-wire system can be used for the VX-200SZ.

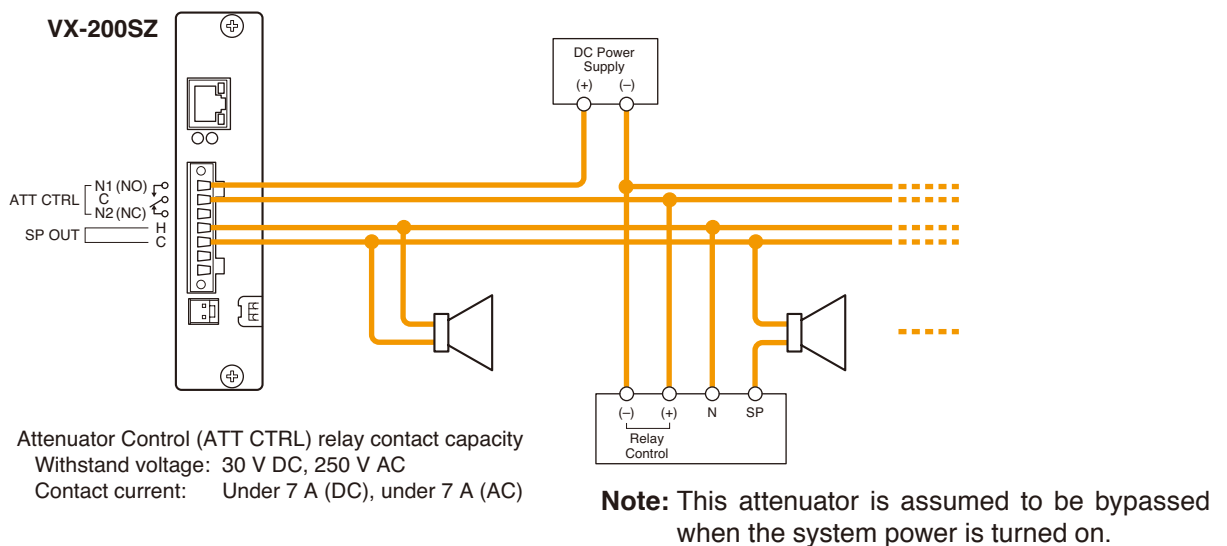

### 3.5. VX-200SI and VX-200SO Connection to External Devices

[VX-2000 Rear]

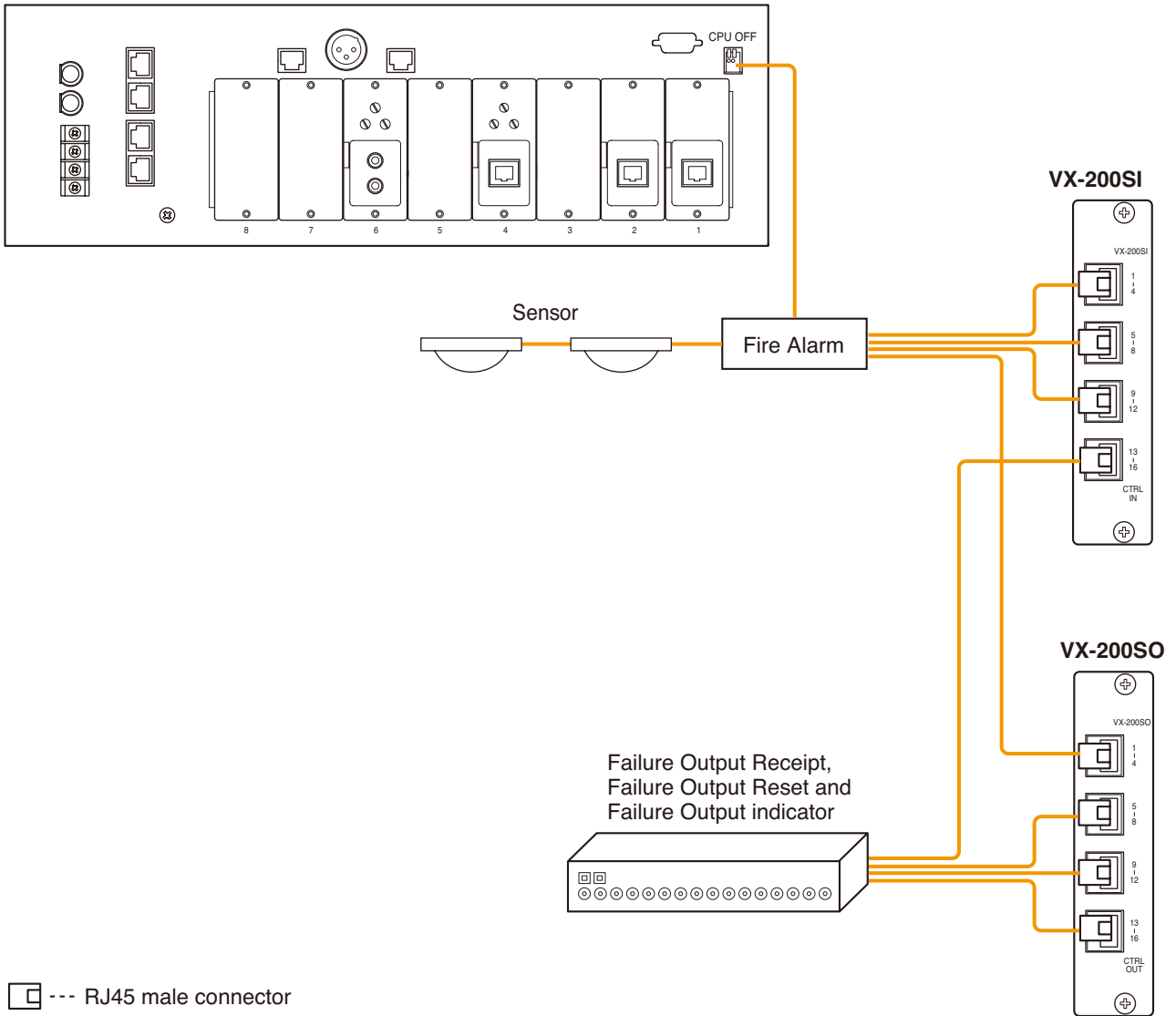

## 4. CONNECTIONS BETWEEN VX-2000SF AND STANDBY AMPLIFIER

[When VP-2241 is used]

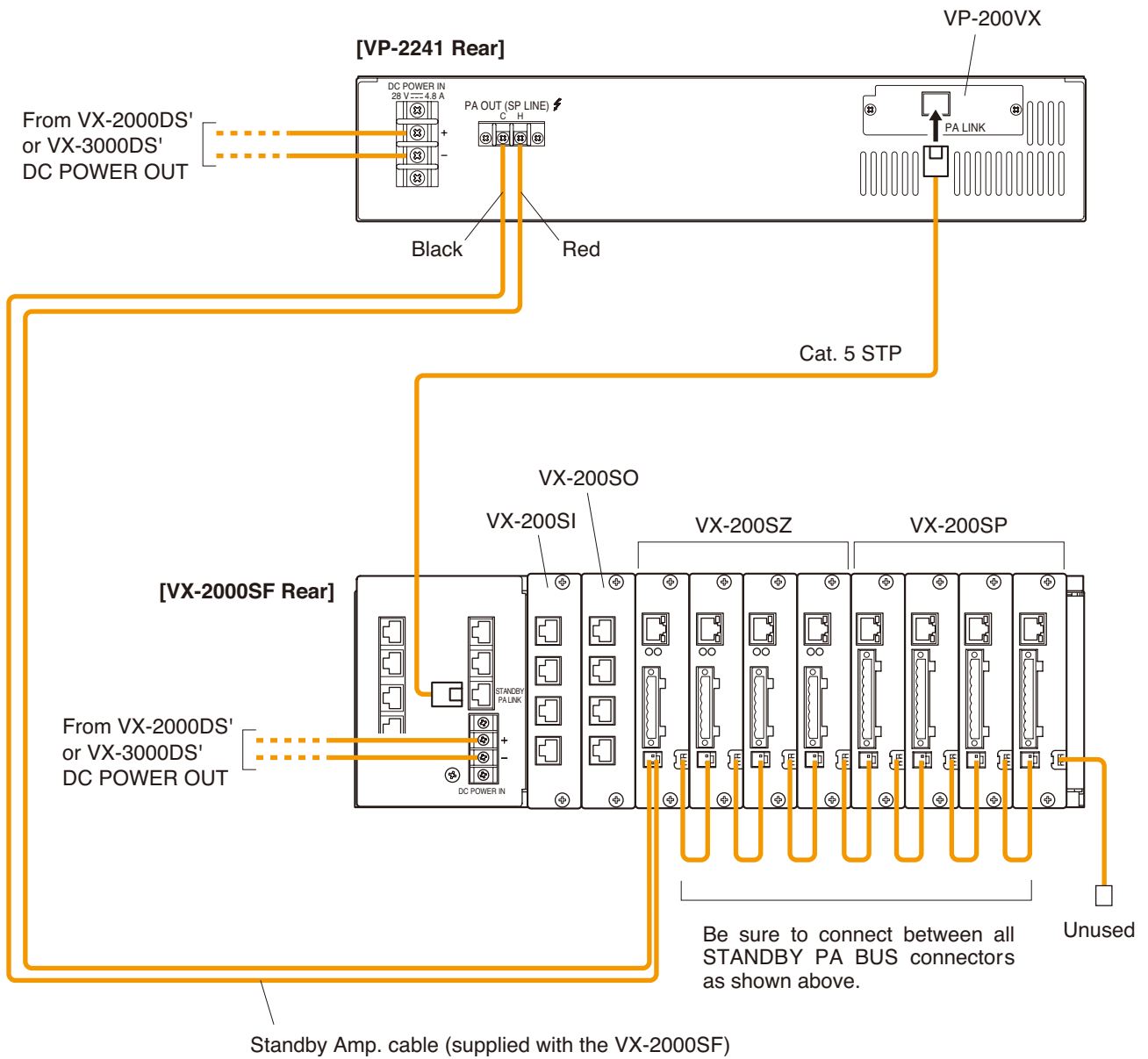

[When VP-3504 is used]

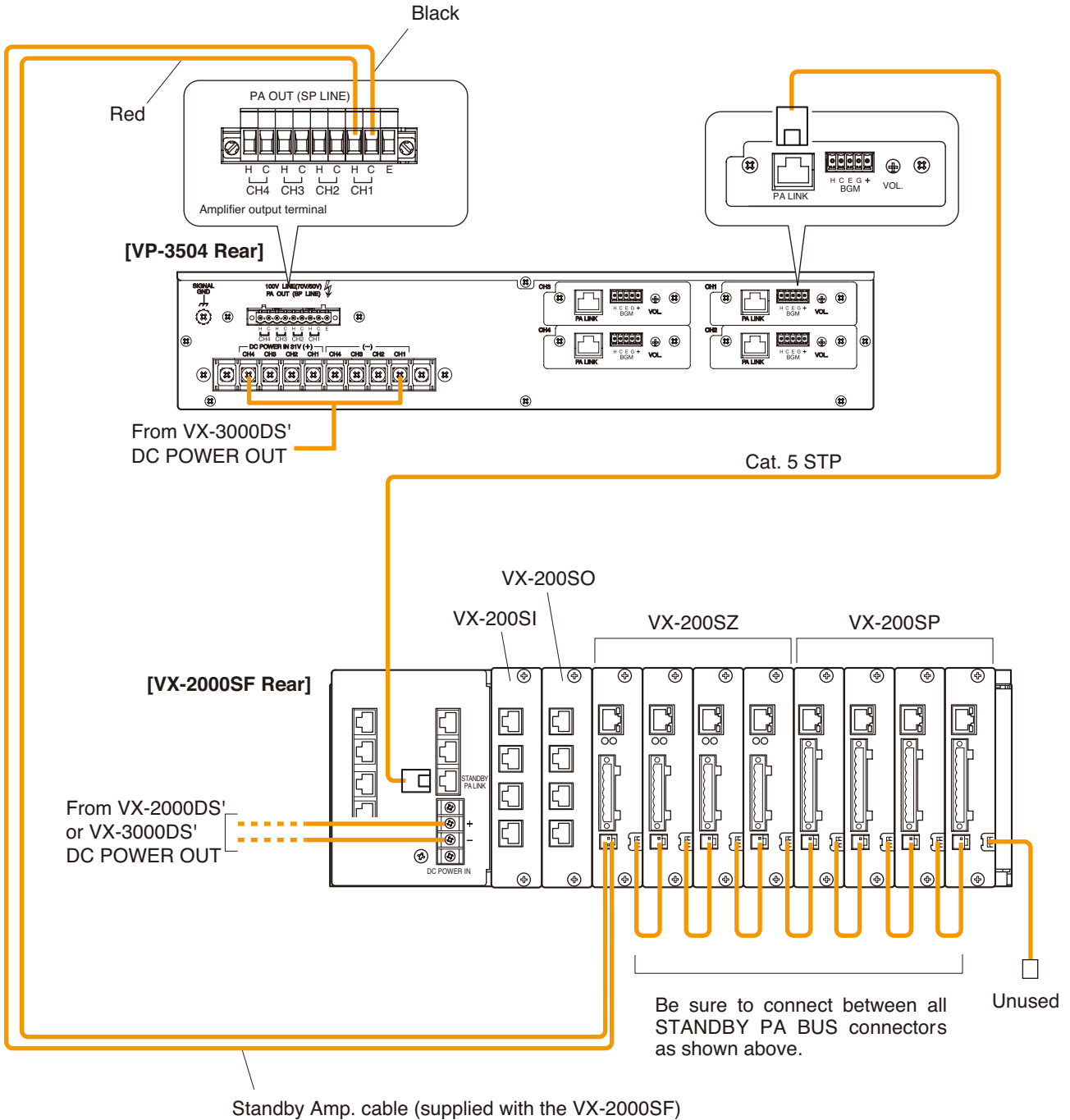

--- RJ45 male connector



## 5. VX-2000 CABLE USAGE TABLE

This table shows the cables to be used in the VX-2000 and their connection locations.

### [RM-200XF]

Terminal to Connect		Cable Type			Equipment to be Connected to		
Terminal Name	Equipment Receptacle	Plug	Cable Type	Plug	Equipment	Terminal Name	Equipment Receptacle
LINK	9P Plug-in screw connector	Unprocessed cable end	Cat. 5 STP	RJ45 (male)	VX-200XR	—	RJ45 (female)
				Unprocessed cable end	RM-200X	LINK	RJ45 (female)
				Unprocessed cable end	RM-200XF	LINK	9P plug-in screw connector
LINK (DC Power In +/-)	9P Plug-in screw connector	Unprocessed cable end	12 – 24 AWG	Round terminal	VX-2000DS/3000DS	DC POWER OUT	Screw terminal

### [RM-200X]

Terminal to Connect		Cable Type			Equipment to be Connected to		
Terminal Name	Equipment Receptacle	Plug	Cable Type	Plug	Equipment	Terminal Name	Equipment Receptacle
LINK	RJ45 (female)	RJ45 (male)	Cat. 5 STP	RJ45 (male)	VX-200XR	—	RJ45 (female)
				Unprocessed cable end	RM-200X	LINK	RJ45 (female)
				Unprocessed cable end	RM-200XF	LINK	9P plug-in screw connector
DC IN	DC Jack	DC plug (Outer diameter: F5.5 mm Inner diameter: F2.1 mm length: 9.5 mm)	—	—	AC Adapter	—	—
				Round terminal	VX-2000DS/3000DS	DC POWER OUT	Screw terminal
EXT MIC IN	A3.5 mm-diameter Mini-jack	A3.5 mm-diameter Mini-plug	1-core shielded cable	—	External microphone	—	—

### [VX-2000]

Terminal to Connect		Cable Type			Equipment to be Connected to		
Terminal Name	Equipment Receptacle	Plug	Cable Type	Plug	Equipment	Terminal Name	Equipment Receptacle
RS-232C	9P D-sub connector (male)	9P D-sub connector (female)	Cross cable	9P D-sub connector (female)	PC	RS-232C	9P D-sub connector (male)
CTRL IN	RJ45 (female)	RJ45 (male)	Cat. 5 STP	Unprocessed cable end	Fire alarm system / other control unit	—	—
CTRL OUT	RJ45 (female)	RJ45 (male)	Cat. 5 STP	Unprocessed cable end	Fire alarm system / other control unit	—	—
DATA LINK	RJ45 (female)	RJ45 (male)	Cat. 5 STP	RJ45 (male)	VX-2000SF	DATA LINK	RJ45 (female)
AUDIO LINK OUT	RJ45 (female)	RJ45 (male)	Cat. 5 STP	RJ45 (male)	VX-2000SF	AUDIO LINK IN	RJ45 (female)
DC POWER IN	2P screw terminal	Round terminal	—	Round terminal	VX-2000DS/3000DS	DC POWER OUT	Screw terminal
MONITOR OUT	3P XLR connector (male)	3P XLR connector (female)	2-core shielded cable	—	Power amplifier	—	—
CPU OFF	Push-in terminal block	Unprocessed cable end	20 – 26 AWG	—	Fire alarm system / other control unit	—	—

**[VX-200XR]**

Terminal to Connect		Cable Type			Equipment to be Connected to		
Terminal Name	Equipment Receptacle	Plug	Cable Type	Plug	Equipment	Terminal Name	Equipment Receptacle
—	RJ45 (female)	RJ45 (male)	Cat. 5 STP	Unprocessed cable end	RM-200XF	LINK	9P Plug-in screw connector
				RJ45 (male)	RM-200X	LINK	RJ45 (female)

**[VX-200XI]**

Terminal to Connect		Cable Type			Equipment to be Connected to		
Terminal Name	Equipment Receptacle	Plug	Cable Type	Plug	Equipment	Terminal Name	Equipment Receptacle
—	RJ45 (female)	RJ45 (male)	Cat. 5 STP	—	Audio input equipment with control output	—	—

**[VX-2000SF]**

Terminal to Connect		Cable Type			Equipment to be Connected to		
Terminal Name	Equipment Receptacle	Plug	Cable Type	Plug	Equipment	Terminal Name	Equipment Receptacle
DS-SF LINK 1, 2	RJ45 (female)	RJ45 (male)	Cat. 5 STP	RJ45 (male)	VX-2000DS/3000DS	DS-SF LINK	RJ45 (female)
DATA LINK	RJ45 (female)	RJ45 (male)	Cat. 5 STP	RJ45 (male)	VX-2000 VX-2000SF	DATA LINK	RJ45 (female)
STANDBY PA LINK	RJ45 (female)	RJ45 (male)	Cat. 5 STP	RJ45 (male)	VP-200VX VP-3154/3304/3504	PA LINK	RJ45 (female)
AUDIO LINK IN	RJ45 (female)	RJ45 (male)	Cat. 5 STP	RJ45 (male)	VX-2000 VX-2000SF	AUDIO LINK OUT	RJ45 (female)
AUDIO LINK OUT	RJ45 (female)	RJ45 (male)	Cat. 5 STP	RJ45 (male)	Standby amplifier VX-2000SF	AUDIO LINK IN	RJ45 (female)
DC POWER IN	2P screw terminal	Round terminal	—	Round terminal	VX-2000DS/3000DS	DC POWER OUT	Screw terminal

**[VX-200SP]**

Terminal to Connect		Cable Type			Equipment to be Connected to		
Terminal Name	Equipment Receptacle	Plug	Cable Type	Plug	Equipment	Terminal Name	Equipment Receptacle
PA LINK	RJ45 (female)	RJ45 (male)	Cat. 5 STP	RJ45 (male)	VP-200VX VP-3154/3304/3504	PA LINK	RJ45 (female)
LINE MONITOR	Plug-in screw connector	Unprocessed cable end	16 – 24AWG	Unprocessed cable end	Speaker termination	Speaker termination	Push-in terminal block
ATT CTRL	Plug-in screw connector	Unprocessed cable end	3-wire: 16 – 24AWG 4-wire: Twisted pair cable	Unprocessed cable end	External attenuator	—	—
SP OUT	Plug-in screw connector	Unprocessed cable end	16 – 24AWG	Unprocessed cable end	Speaker	Speaker terminal	Push-in terminal block
PA IN	Plug-in screw connector	Unprocessed cable end	16 – 24AWG	Round or Y terminal	VP-2064/2122/ 2241/2421	PA OUT (SP LINE)	2P screw terminal
				Unprocessed cable end	VP-3154/3304/ 3504		Plug-in screw connector
STANDBY PA BUS	2P VH connector	Round or Y terminal	18AWG	Round or Y terminal	Standby amplifier VP-2064/2122/ 2241/2421	PA OUT (SP LINE)	2P screw terminal
				Unprocessed cable end	VP-3154/3304/ 3504		Plug-in screw connector
STANDBY PA BUS	2P VH connector	—	PCB Cable	—	VX-200SP VX-200SZ	STANDBY PA BUS	—

**[VX-200SZ]**

Terminal to Connect		Cable Type			Equipment to be Connected to		
Terminal Name	Equipment Receptacle	Plug	Cable Type	Plug	Equipment	Terminal Name	Equipment Receptacle
PA LINK	RJ45 (female)	RJ45 (male)	Cat. 5 STP	RJ45 (male)	VP-200VX VP-3154/3304/3504	PA LINK	RJ45 (female)
ATT CTRL	Plug-in screw connector	Unprocessed cable end	4-wire: Twisted pair cable	Unprocessed cable end	External attenuator	—	—
SP OUT	Plug-in screw connector	Unprocessed cable end	16 – 24AWG	Unprocessed cable end	Speaker	Speaker terminal	Push-in terminal block
PA IN	Plug-in screw connector	Unprocessed cable end	16 – 24AWG	Round or Y terminal	VP-2064/2122/ 2241/2421	PA OUT (SP LINE)	2P screw terminal
				Unprocessed cable end	VP-3154/3304/ 3504		Plug-in screw connector
STANDBY PA BUS	2P VH connector	Round or Y terminal	18AWG	Round or Y terminal	Standby amplifier VP-2064/2122/ 2241/2421	PA OUT (SP LINE)	2P screw terminal
				Unprocessed cable end	VP-3154/3304/ 3504		Plug-in screw connector
STANDBY PA BUS	2P VH connector	—	PCB Cable	—	VX-200SP VX-200SZ	STANDBY PA BUS	—

**[VX-200SI]**

Terminal to Connect		Cable Type			Equipment to be Connected to		
Terminal Name	Equipment Receptacle	Plug	Cable Type	Plug	Equipment	Terminal Name	Equipment Receptacle
CTRL IN	RJ45 (female)	RJ45 (male)	Cat. 5 STP	Unprocessed cable end	External equipment	Control output	—

**[VX-200SO]**

Terminal to Connect		Cable Type			Equipment to be Connected to		
Terminal Name	Equipment Receptacle	Plug	Cable Type	Plug	Equipment	Terminal Name	Equipment Receptacle
CTRL OUT	RJ45 (female)	RJ45 (male)	Cat. 5 STP	Unprocessed cable end	External equipment	Control input	—

**[VP-2064/2122/2241/2421]**

Terminal to Connect		Cable Type			Equipment to be Connected to		
Terminal Name	Equipment Receptacle	Plug	Cable Type	Plug	Equipment	Terminal Name	Equipment Receptacle
PA OUT (SP LINE)	Screw terminal	Round or Y terminal	14 – 22AWG	Unprocessed cable end	VX-200SZ VX-200SP	PA IN	Plug-in screw connector
Standby amplifier PA OUT (SP LINE)	Screw terminal	Round or Y terminal	18AWG	2P VH connector	VX-200SZ VX-200SP	STANDBY PA BUS	2P VH connector
DC POWER IN	2P screw terminal	Round terminal	—	Round terminal	VX-2000DS/3000DS	DC POWER OUT	Screw terminal

**[VP-3154/3304/3504]**

Terminal to Connect		Cable Type			Equipment to be Connected to		
Terminal Name	Equipment Receptacle	Plug	Cable Type	Plug	Equipment	Terminal Name	Equipment Receptacle
PA OUT (SP LINE)	Plug-in screw connector	Round or Y terminal	18AWG	Unprocessed cable end	VX-200SZ VX-200SP	PA IN	Plug-in screw connector
Standby amplifier PA OUT (SP LINE)	Plug-in screw connector	Round or Y terminal	18AWG	2P VH connector	VX-200SZ VX-200SP	STANDBY PA BUS	2P VH connector
DC POWER IN	8P screw terminal	Round terminal	—	Round terminal	VX-3000DS	DC POWER OUT	Screw terminal

**[VP-200VX]**

Terminal to Connect		Cable Type			Equipment to be Connected to		
Terminal Name	Equipment Receptacle	Plug	Cable Type	Plug	Equipment	Terminal Name	Equipment Receptacle
PA LINK	RJ45 (female)	RJ45 (male)	Cat. 5 STP	RJ45 (male)	VX-200SZ VX-200SP	PA LINK	RJ45 (female)
					VX-2000SF	STANDBY PA LINK	RJ45 (female)

**[VX-2000DS]**

Terminal to Connect		Cable Type			Equipment to be Connected to		
Terminal Name	Equipment Receptacle	Plug	Cable Type	Plug	Equipment	Terminal Name	Equipment Receptacle
AC IN	3P inlet	—	Supplied cable	—	AC230 V, 50/60 Hz	—	—
DS-SF LINK	RJ45 (female)	RJ45 (male)	Cat. 5 STP	RJ45 (male)	VX-2000SF	DS-SF LINK	RJ45 (female)
BATTERY POWER IN	Screw terminal	Unprocessed cable end	6-1/0AWG	Unprocessed cable end	Lead-acid battery	Electrode (+,-)	—
DC POWER OUT	Screw terminal	Round terminal	—	Round terminal	VX-2000 VX-2000SF VP-2064/2122/2241 2421	DC POWER IN	2P screw terminal
				DC plug (Outer diameter: F5.5 mm Inner diameter: F2.1 mm Length: 9.5 mm)	RM-200X	DC IN	DC jack
				12 – 24 AWG	Unprocessed cable end	RM-200XF	LINK (DC Power In +/-)
PS IN	Screw terminal	Round terminal	10 – 14 AWG (line resistance within 10 mΩ)	Round terminal	VX-200PS	PS OUT	Screw terminal

**[VX-200PS]**

Terminal to Connect		Cable Type			Equipment to be Connected to		
Terminal Name	Equipment Receptacle	Plug	Cable Type	Plug	Equipment	Terminal Name	Equipment Receptacle
AC IN	3P inlet	—	Supplied cable	—	AC230 V, 50/60 Hz	—	—
PS OUT	Screw terminal	Round terminal	10 – 14 AWG (line resistance within 10 mΩ)	Round terminal	VX-2000DS	PS IN	Screw terminal

**[VX-3000DS]**

Terminal to Connect		Cable Type			Equipment to be Connected to		
Terminal Name	Equipment Receptacle	Plug	CableType	Plug	Equipment	Terminal Name	Equipment Receptacle
AC POWER IN1,2	3P inlet	—	Supplied cable	—	230 V AC, 50/60 Hz 220 V AC, 50/60 Hz	—	—
DS LINK IN/OUT	RJ45 (female)	RJ45 (male)	Cat. 5 STP	RJ45 (male)	SX-2000SM SX-2100AO VX-2000SF VM-3240VA VM-3360VA VM-3240E VM-3360E	DS LINK DS-SF LINK	RJ45 (female)
BATTERY POWER IN	Screw terminal	Unprocessed cable end	6-1/0 AWG	Unprocessed cable end	Lead-acid battery	Electrode (+, -)	—
POWER OUT 20-32 V MAX 25 A	Screw terminal	Round terminal	14-18 AWG	Round terminal	VX-2000 VX-2000SF VP-2064/2122/2241/ 2421 VP-3154/3304/3504	DC POWER IN	2P screw terminal
			—	DC plug (Outer diameter: F5.5 mm Inner diameter: F2.1 mm Length: 9.5 mm)	RM-200X RM-200SA	DC IN	DC jack
			12-24 AWG	Unprocessed cable end	RM-200XF	LINK (DC Power In+)	9P plug-in screw terminal
			14-18 AWG	Round terminal	SX-2000SM SX-2100AI SX-2000AO SX-2100AO SX-2000CI SX-2000CO	DC POWER IN	4P removable terminal plug
			8-10 AWG	Round terminal	VM-3240VA VM-3360VA VM-3240E VM-3360E	DC POWER IN	2P screw terminal
			12-24 AWG	Round terminal	RM-200SF RM-300MF	DC IN 24V	Screw terminal
POWER OUT 20-32 V MAX 5A	2P plug in screw terminal	Unprocessed cable end	14-18 AWG	Round terminal	VX-2000 VX-2000SF	DC POWER IN	2P screw terminal
			—	DC plug (Outer diameter: F5.5 mm Inner diameter: F2.1 mm Length: 9.5 mm)	RM-200X RM-200SA	DC IN	DC jack
			12-24 AWG	Unprocessed cable end	RM-200XF	LINK (DC Power In+)	9P plug-in screw terminal
			14-18 AWG	Round terminal	SX-2000SM SX-2100AI SX-2000AO SX-2100AO SX-2000CI SX-2000CO	DC POWER IN	4P removable terminal plug
			12-24 AWG	Round terminal	RM-200SF RM-300MF	DC IN 24V	Screw terminal
POWER OUT 20-24 V MAX 0.3 A	2P plug in screw terminal	Unprocessed cable end	—	DC plug (Outer diameter: F5.5 mm Inner diameter: F2.1 mm Length: 9.5 mm)	RM-200M	DC IN	DC jack

## 6. CONNECTION CABLE PIN ASSIGNMENT

The pin assignment of the RJ45 connector used to connect one or both ends of the connection cable is explained here.

### 6.1. RJ45 Connector-to-RJ45 Connector Connections

Connect an RJ45 connector to both ends of the Cat. 5 STP cable and make the following connections:

[Source to Connect]		[Source to be Connected to]	
Component	Connector Name	Component	Connector Name
VX-2000	DATA LINK	VX-2000SF	DATA LINK
VX-2000	AUDIO LINK OUT	VX-2000SF	AUDIO LINK IN
VX-2000SF	AUDIO LINK OUT	Next VX-2000SF	AUDIO LINK IN
VX-2000SF	DATA LINK	Next VX-2000SF	DATA LINK
VX-2000SF	STANDBY PA LINK	VP-200VX/VP-3000 series	PA LINK
VX-2000SF	DS-SF LINK 1, 2	VX-2000DS/3000DS	DS-SF LINK/DS LINK IN
VX-200SP	PA LINK	VP-200VX/VP-3000 series	PA LINK
VX-200SZ	PA LINK	VP-200VX/VP-3000 series	PA LINK

#### [RJ45 connector pin assignment]

RJ45 Pin No.	Colour*	Pair
①	Orange / white	[Diagram of pair 1: pins 1 and 2]
②	Orange	
③	Green / white	[Diagram of pair 2: pins 3 and 6]
④	Blue	
⑤	Blue / white	[Diagram of pair 3: pins 4 and 5]
⑥	Green	
⑦	Brown / white	[Diagram of pair 4: pins 7 and 8]
⑧	Brown	
Shield	Shield	

\* Differs from cable makers. In wiring, refer to the cable specifications for colour.

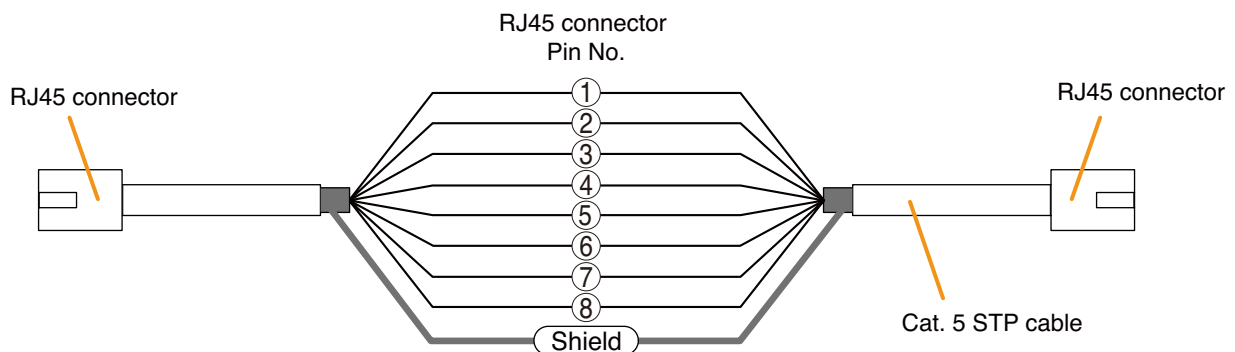

## 6.2. VX-200XR to Remote Microphone (RM-200XF or RM-200X) Connections

RM-200XF or RM-200X Assignment	RJ45 Pin No.	Colour	Pair	VX-200XR Assignment
Monitor in (H)	①	Orange / white	[Diagram: Pair 1]	Monitor out (H)
Monitor in (C)	②	Orange		Monitor out (C)
RM data	③	Green / white	[Diagram: Pair 2]	RM data
Audio out (H)	④	Blue		Audio in (H)
Audio out (C)	⑤	Blue / white	[Diagram: Pair 3]	Audio in (C)
RM data	⑥	Green		RM data
DC power in (+)	⑦	Brown / white	[Diagram: Pair 4]	DC power out (+)
DC power in (-)	⑧	Brown		DC power out (-)
Shield	Shield	Shield		Shield

### Caution

Make sure to connect the Shield terminals of the RM-200XF, RM-200X, and VX-200XR Remote Microphone Input Module to the Cat. 5 STP cable shield. If not connected in this way, the system will not operate correctly when the CPU switch is turned OFF.

Remote Microphones can be connected by way of daisy-chain or free topology configurations.

### • Daisy-chain connection between RM-200XF and VX-200XR

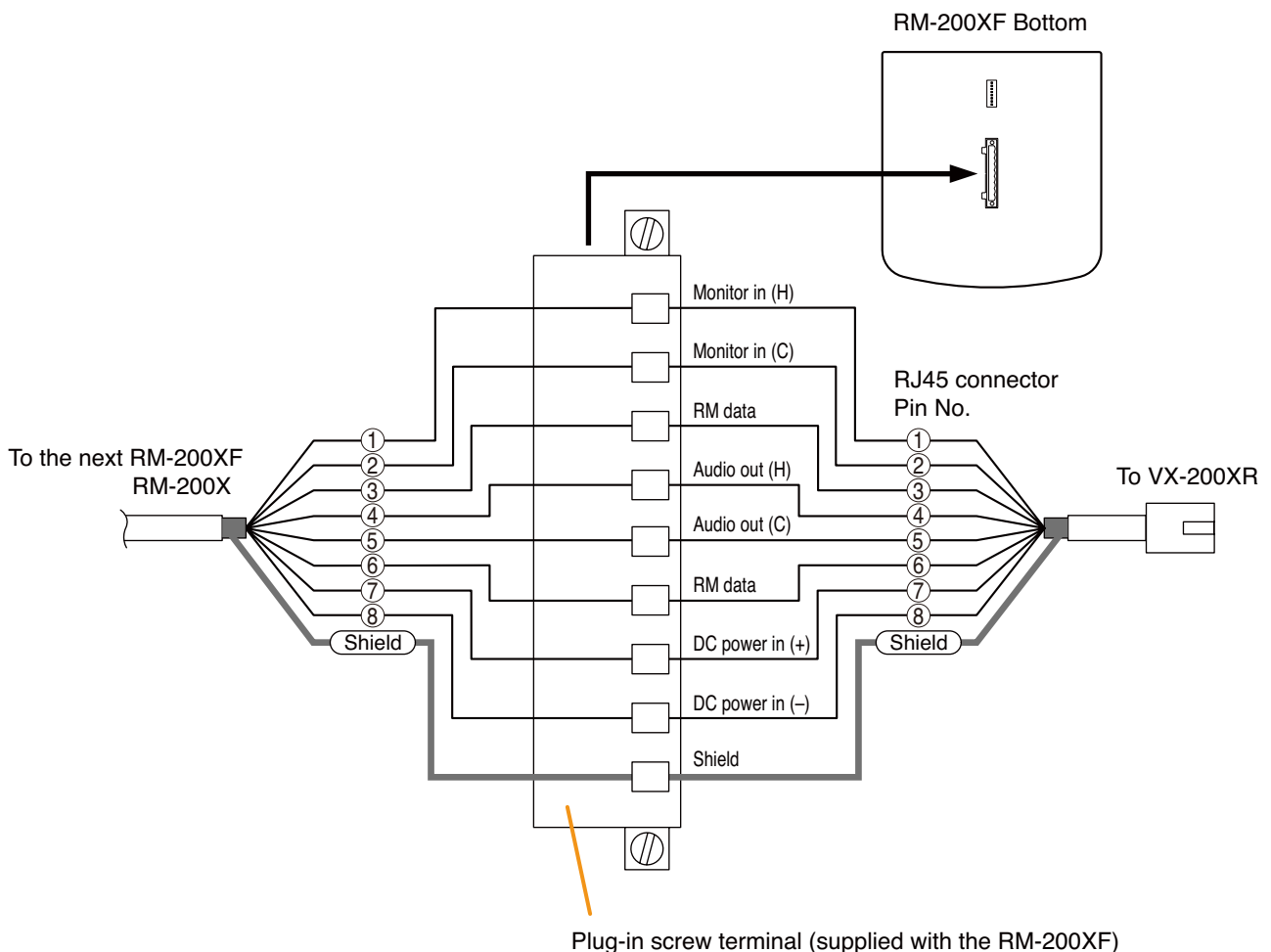

• Daisy-chain connection between RM-200X and VX-200XR

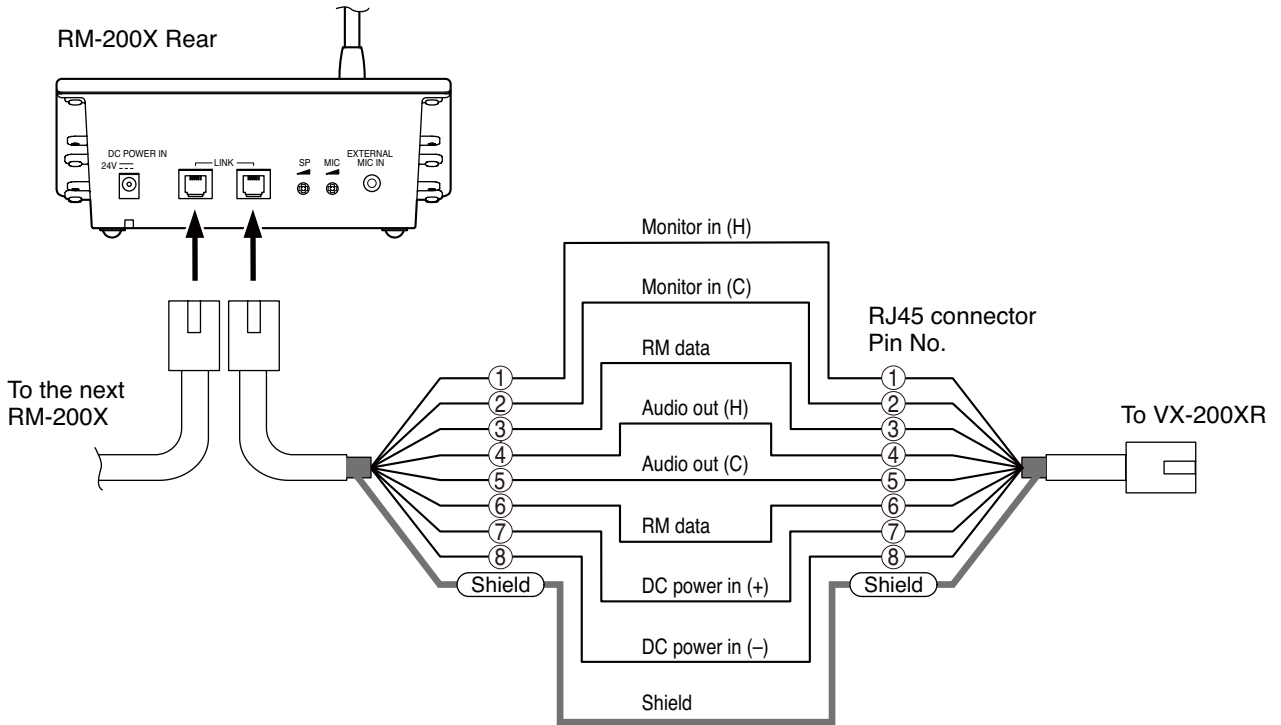

• Free topology connection between RM-200XF or RX-200X and VX-200XR

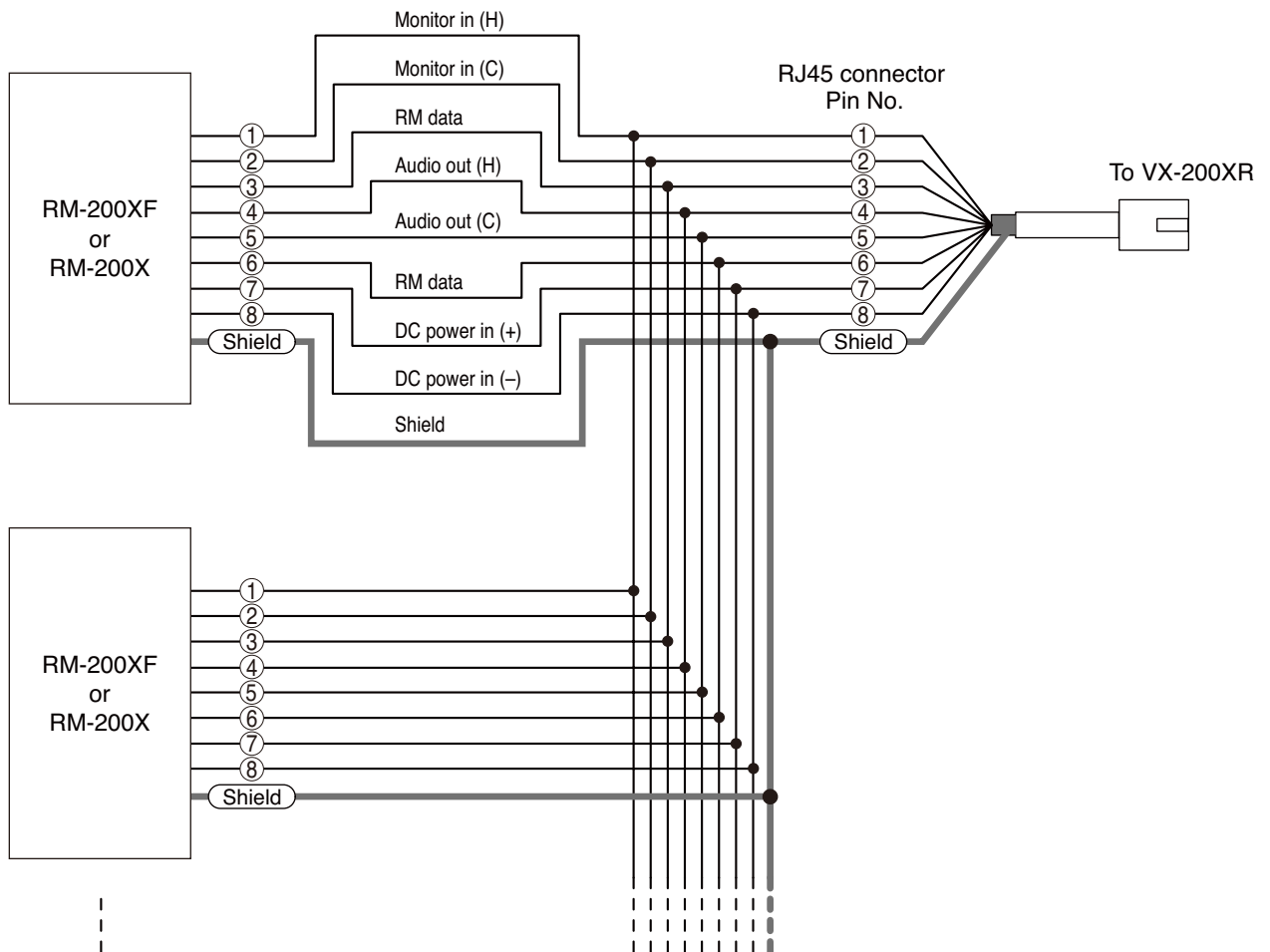



### [Direct power supply to the Remote Microphone]

When a Remote Microphone is located far away from the VX-2000 or many RM-210 units are connected, the Remote Microphone may malfunction due to the voltage drop of power supply.

Also, when more than 1 Remote Microphones, each having one VX-200XR to which many RM-210s are connected, are included in the system, the current consumption could become too large to operate the Remote Microphones.

In the above cases, the Remote Microphone needs to be directly supplied power from the VX-2000DS or VX-3000DS.

For the detailed conditions that power should be directly supplied from the VX-2000DS or VX-3000DS, refer to the "Supplementary tools.xls" file located in the "Supplementary tool" folder on the CD-ROM accompanying the VX-2000.

### [Connection examples]

- Direct power supply from the VX-2000DS or VX-3000DS to the RM-200X assembled with many RM-210s

When many RM-210s are added to the RM-200X, power needs to be directly supplied from the VX-2000DS or VX-3000DS.

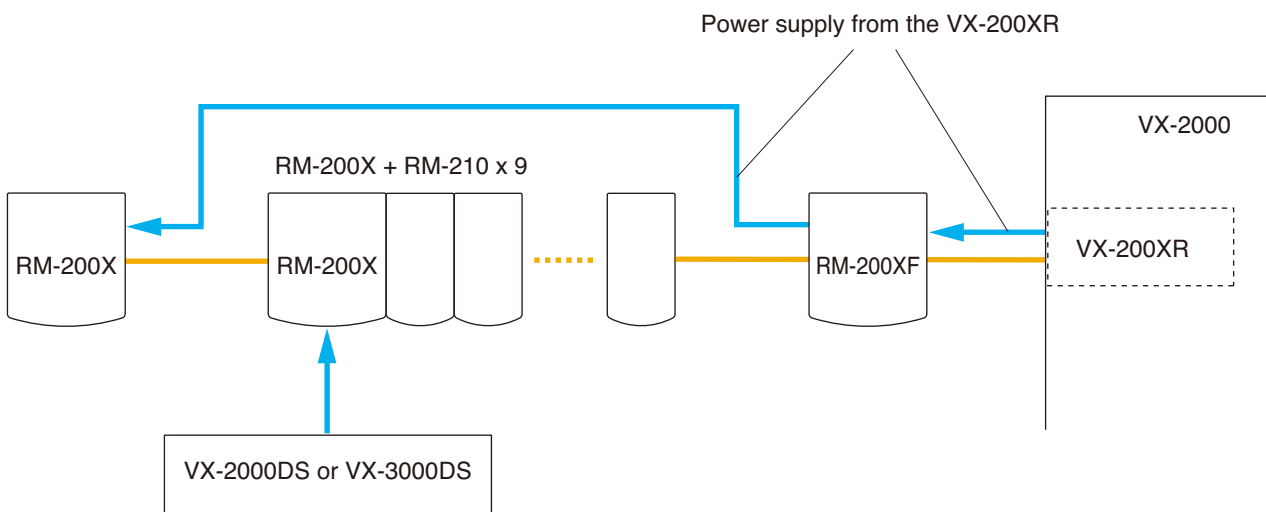

• Direct power supply from the VX-2000DS or VX-3000DS to the RM-200XF

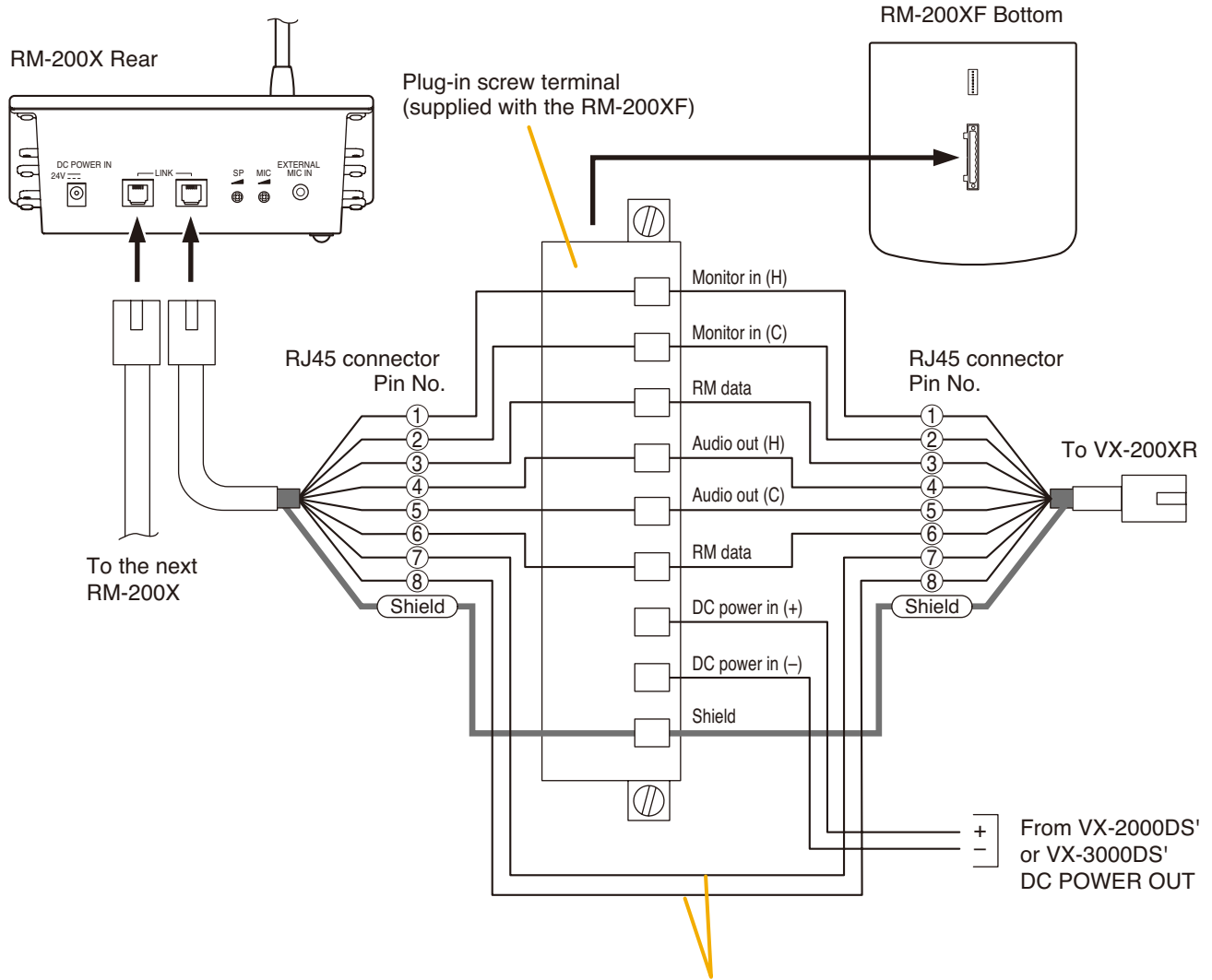

These lines supply power from the VX-200XR to the next Remote Microphone.

• Direct power supply to the RM-200X

If the RM-200X is used for both emergency and general-purpose broadcast applications and the backup power supply is required for AC power failure, supply the power directly from the VX-2000DS or VX-3000DS to the RM-200X's rear-mounted DC POWER IN terminal.

If no backup power supply is required because the Remote Microphone is to be exclusively used for general-purpose broadcasting, AC adapters can also be used to supply the power.

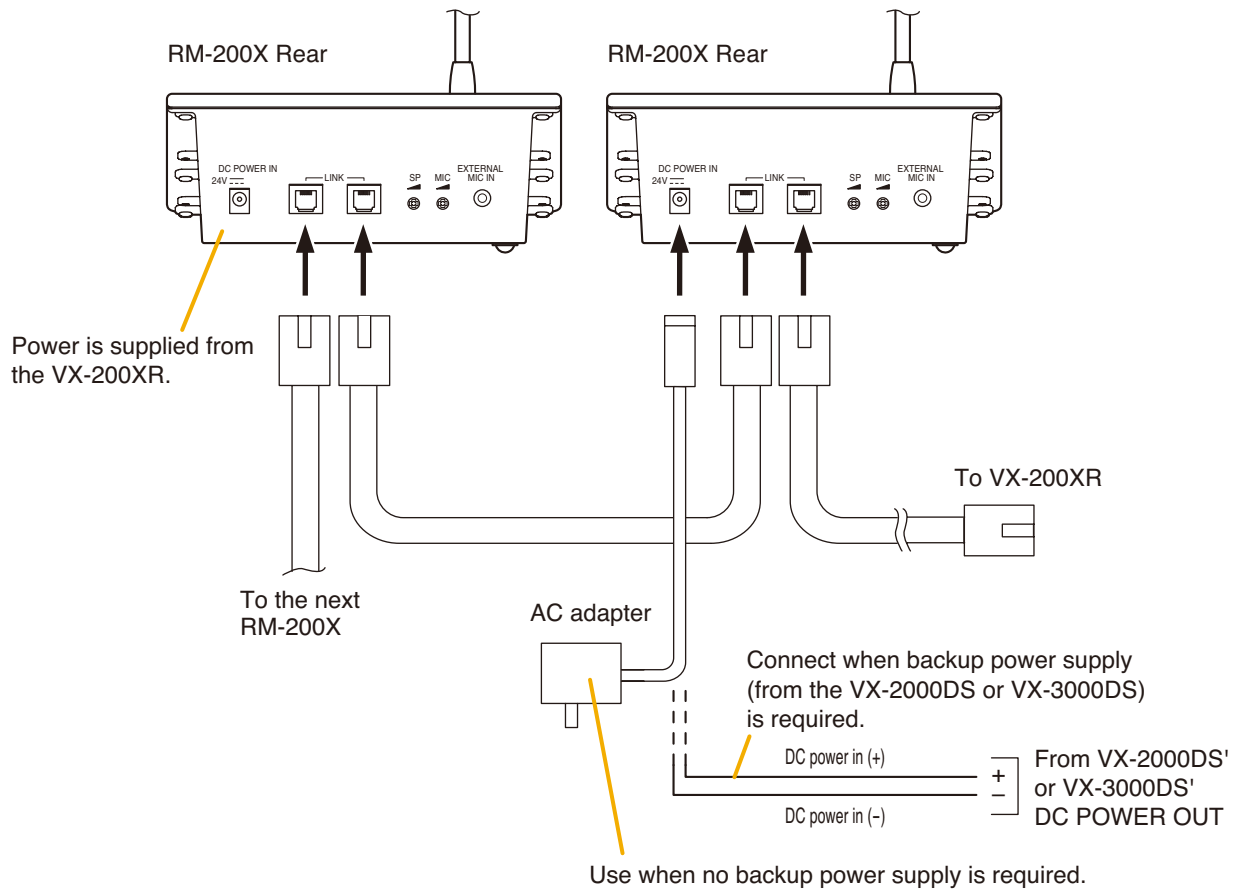

**Usable AC adapter**

24 V DC/over 750 mA (Operation range: 16 – 40 V DC)

Usable power input plug: Non-polarity type

(5.5 mm outer diameter, 2.1 mm inner diameter, and 9.5 mm long)

**Note**

Plugging a DC plug into the RM-200X's DC POWER IN terminal automatically switches the RM-200X's DC power input to this terminal, disconnecting the unit's power supply from the LINK connector. Be sure to firmly secure the DC plug by fixing the power cable onto the RM-200X's bottom-mounted cable hook.

If the DC plug is pulled out, the LINK connector takes over the unit's power supply and is connected to the system power line. This may cause the voltage drop of power supply and increase the current consumption from the VX-200XR, resulting in the system malfunction.

### 6.3. VX-200XI Connections

RJ45 Pin No.	Colour	Pair	Assignment
①	Orange / white	[Orange/White pair]	Control input (+)
②	Orange		Control input (-)
③	Green / white	[Green/White pair]	NC
④	Blue		AUDIO OUT (C)
⑤	Blue / white		AUDIO OUT (H)
⑥	Green		NC
⑦	Brown / white	[Brown/White pair]	NC
⑧	Brown		NC
Shield	Shield		NC

• Connection example

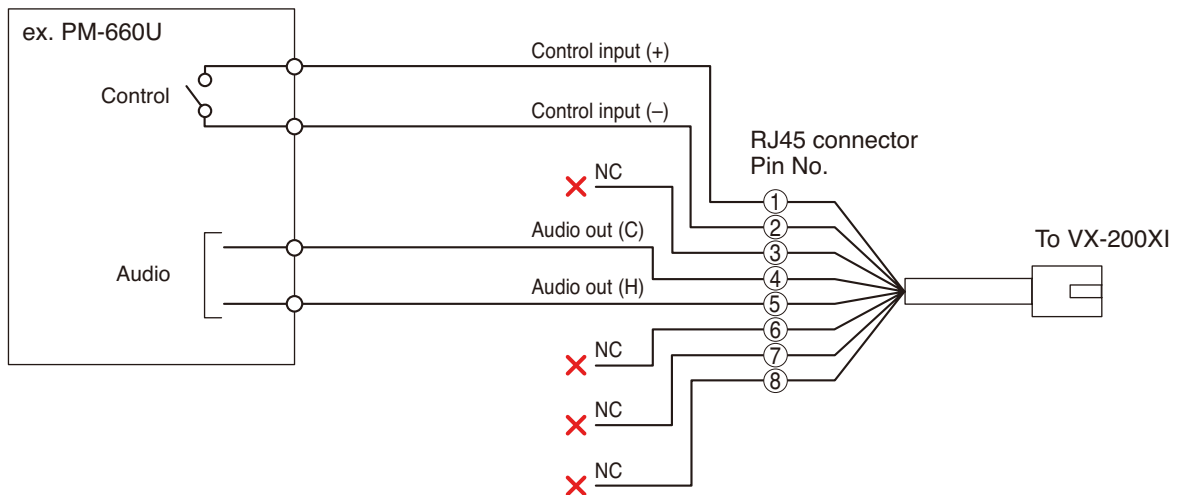

**VX-200XI Control Input**  
**Electrical characteristics**

Open voltage: 17 V DC  
Short circuit current: Under 5 mA

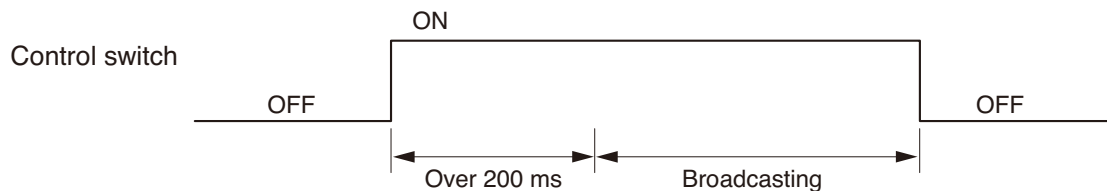

**[VX-200XI's control input insulation]**

Because the VX-200XI's control input uses photocouplers, it can be insulated by performing settings to be externally powered. For the setting procedure, refer to p. 8-22.

RJ45 Pin No.	Colour	Pair	Assignment
①	Orange / white	[Orange / white] [Orange]	Control input (-)
②	Orange		Control input (+)
③	Green / white	[Green / white] [Blue]	NC
④	Blue		AUDIO OUT (C)
⑤	Blue / white	[Blue / white] [Green]	AUDIO OUT (H)
⑥	Green		NC
⑦	Brown / white	[Brown / white] [Brown]	NC
⑧	Brown		NC
Shield	Shield		NC

• **Connection example**

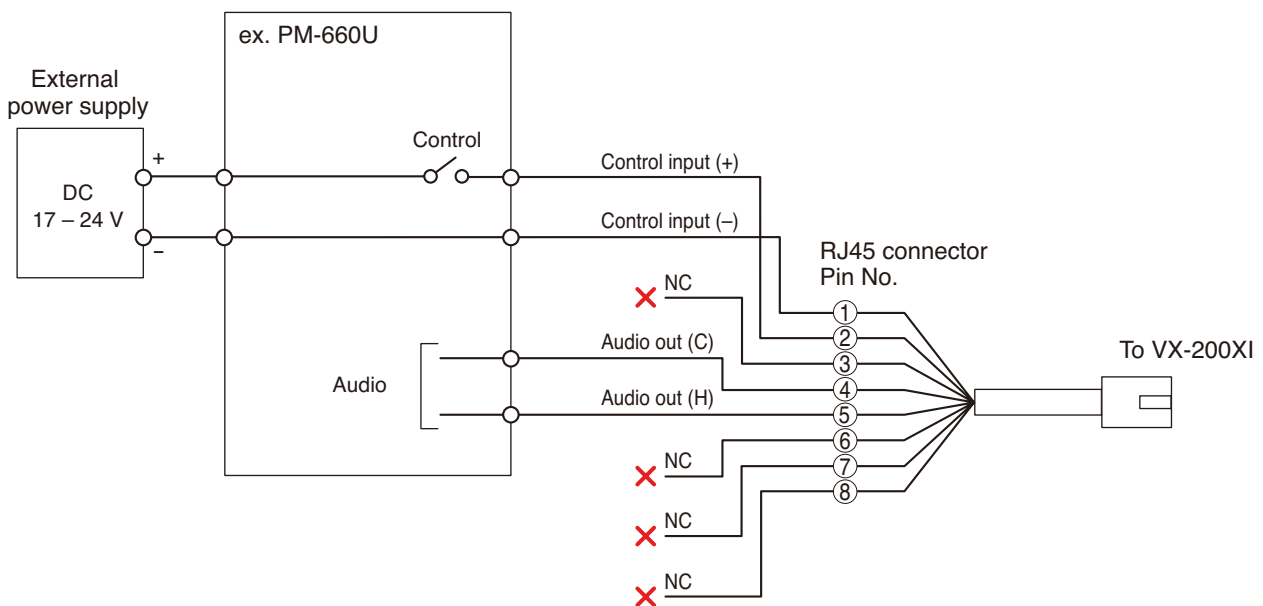

**VX-200XI Control Input (photocoupler-insulated)  
Electrical characteristics**

Voltage requirement: 17 – 24 V DC  
Short circuit current: Under 7 mA  
Control current: 5 – 7 mA

(The photocoupler is turned on with the specified control current from an external power supply connected to the control input terminals.)

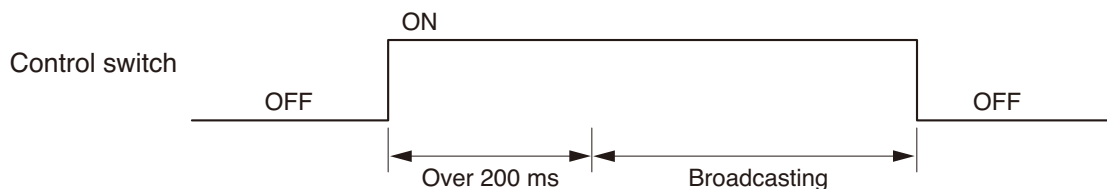

### 6.4. VX-2000 Control Input Connections

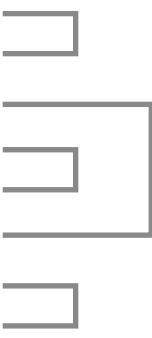
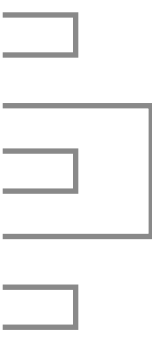
Connector Name	RJ45 Pin No.	Colour	Pair	Assignment
CTRL IN 1 – 8	①	Orange / white		CTRL IN 1
	②	Orange		CTRL IN 2
	③	Green / white		CTRL IN 3
	④	Blue		CTRL IN 6
	⑤	Blue / white		CTRL IN 5
	⑥	Green		CTRL IN 4
	⑦	Brown / white		CTRL IN 7
	⑧	Brown		CTRL IN 8
	Shield	Shield		CTRL IN 1 – 8 Common*
CTRL IN 9 – 16	①	Orange / white		CTRL IN 9
	②	Orange		CTRL IN 10
	③	Green / white		CTRL IN 11
	④	Blue		CTRL IN 14
	⑤	Blue / white		CTRL IN 13
	⑥	Green		CTRL IN 12
	⑦	Brown / white		CTRL IN 15
	⑧	Brown		CTRL IN 16
	Shield	Shield		CTRL IN 9 – 16 Common*

\* Both Common terminals are factory-connected to the VX-2000's internal GND terminal.

*Continued on next page*

• Connection example of the VX-2000's CTRL-IN terminal

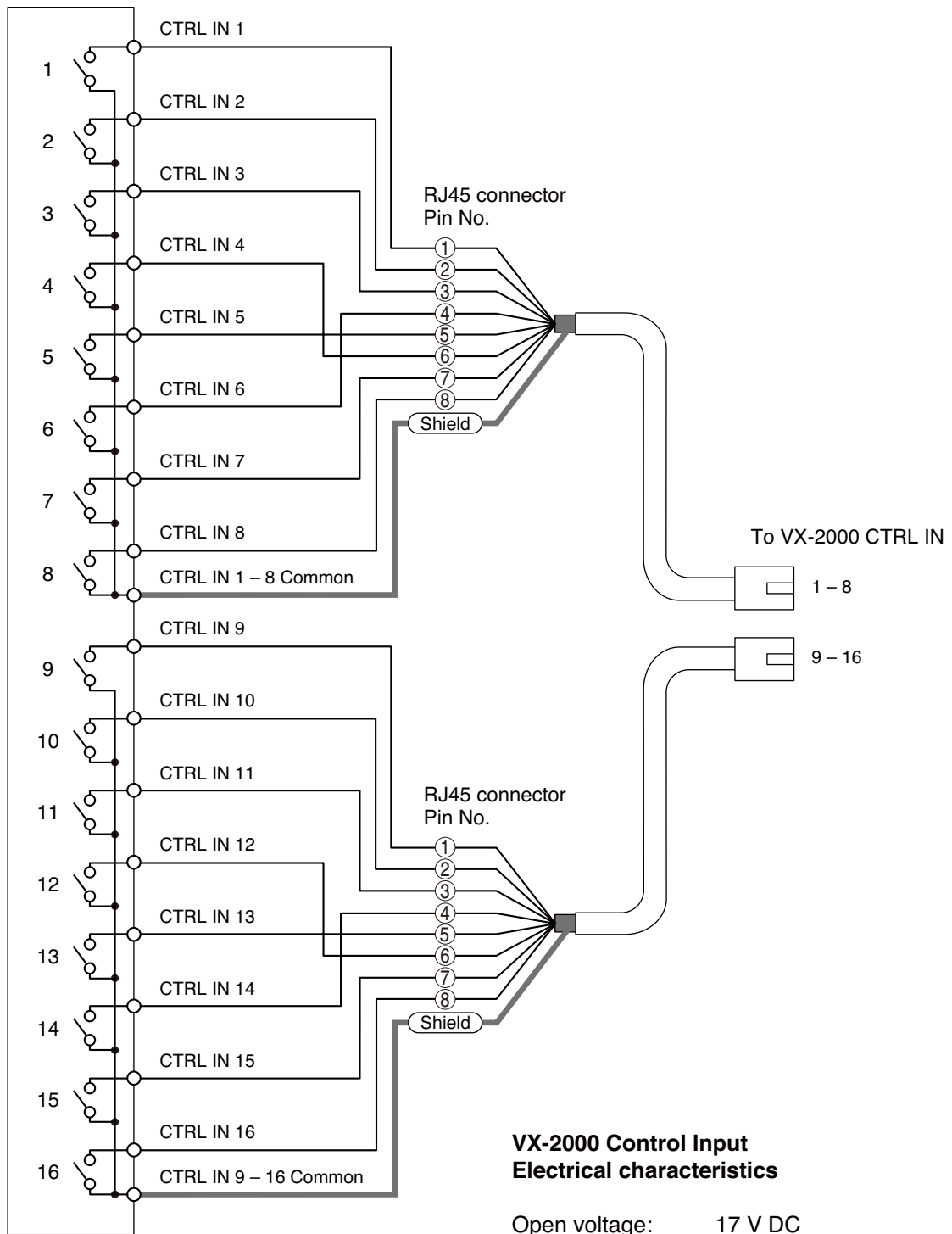

**VX-2000 Control Input  
Electrical characteristics**

Open voltage: 17 V DC  
Short circuit current: Under 5 mA

**[VX-2000 Control input insulation]**

Because the VX-2000's control input uses photocouplers, it can be insulated by performing settings to be externally powered.

This setting disconnects both CTRL IN 1 – 8 Common terminal and CTRL IN 9 – 16 Common terminal from the VX-2000's internal GND terminal, changing them to external power supply terminals. (Refer to p. 8-17 for the setting procedure.)

• **Connection example**

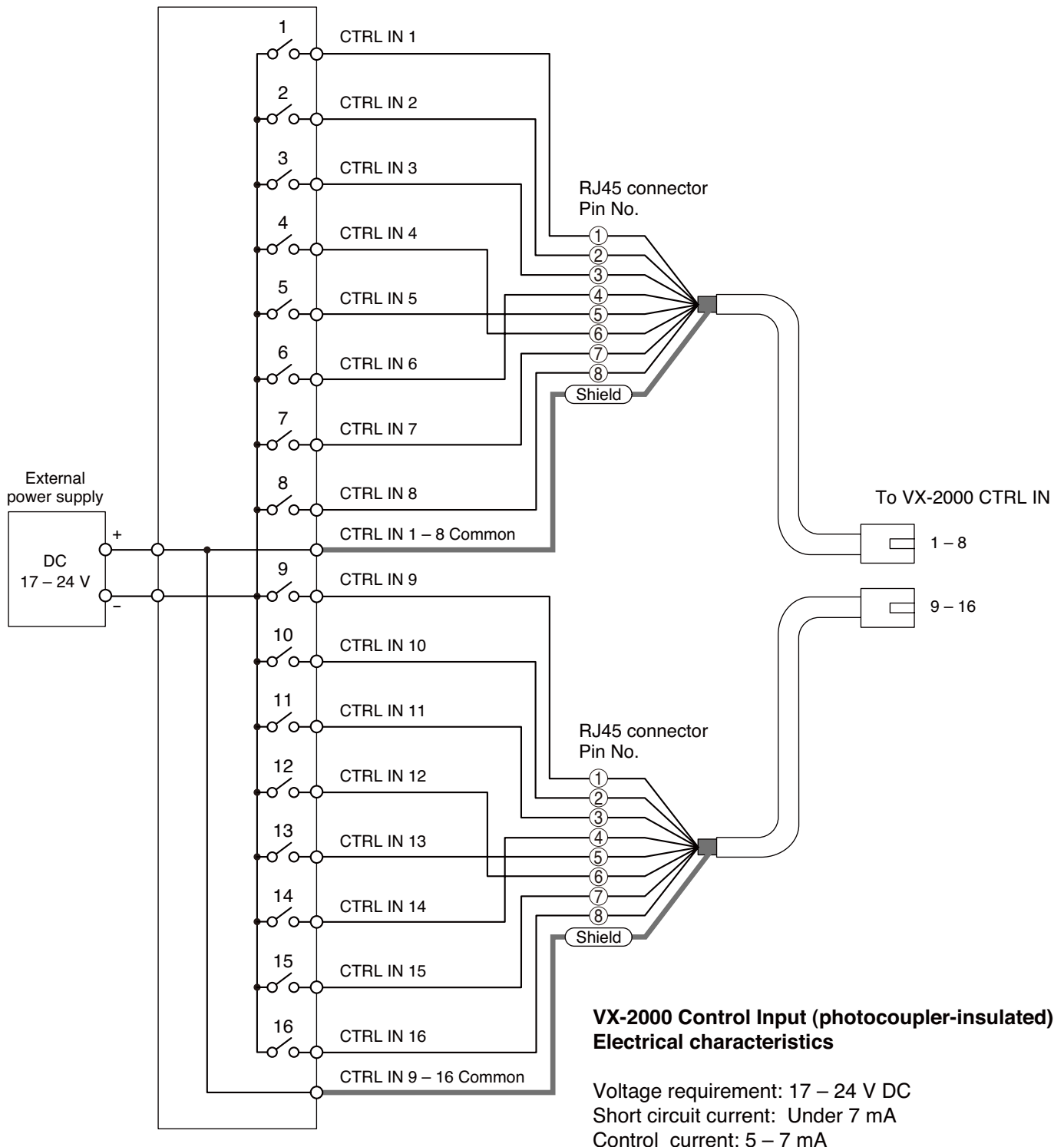



**[Activating the control inputs]**

Two types of activation methods "Level trigger" and "Pulse trigger" are available for the control inputs depending on assigned functions.

**• Level trigger**

Applicable function: Interrupt Broadcast, Control Output, and Failure Display Input, Volume UP/DOWN, Emergency Silence

The level trigger requires to be retained ON for at least 100 ms for the control activation. A broadcast or control is activated while the corresponding input is ON.

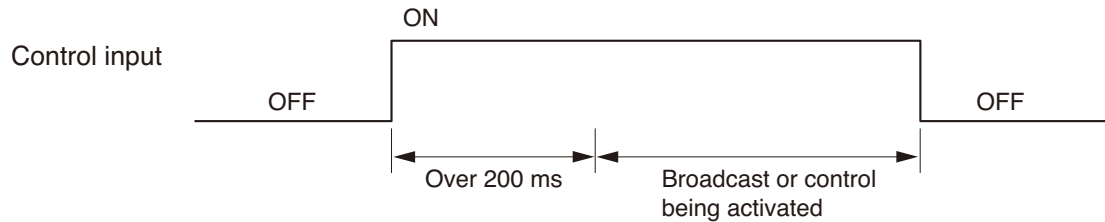

**• Pulse trigger**

Applicable function: EV Broadcast, Base Pattern Change, Base Pattern End, Audio Monitor, Failure Output Receipt, Failure Output Reset, Emergency Activation, and Emergency Reset

The control activation is made valid when one-shot pulse of over 100 ms is applied to a control input. The corresponding broadcast or control is then activated.

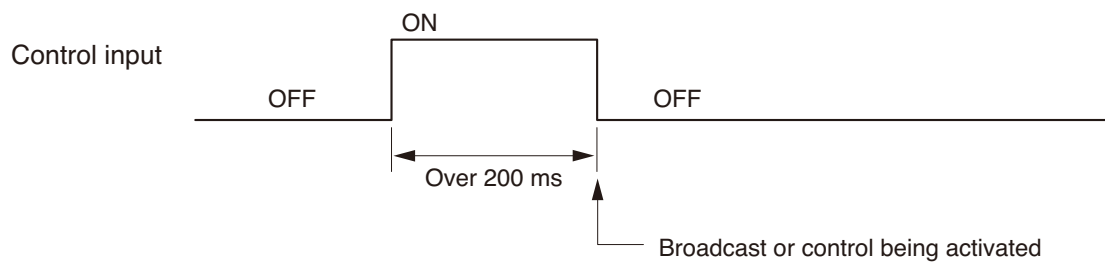

### 6.5. VX-2000 Control Output Connections

Connector Name	RJ45 Pin No.	Colour	Pair	Assignment
CTRL IN 1 – 8	①	Orange / white		CTRL IN 1
	②	Orange		CTRL IN 2
	③	Green / white		CTRL IN 3
	④	Blue		CTRL IN 6
	⑤	Blue / white		CTRL IN 5
	⑥	Green		CTRL IN 4
	⑦	Brown / white		CTRL IN 7
	⑧	Brown		CTRL IN 8
	Shield	Shield		CTRL IN 1 – 8 Common*
CTRL IN 9 – 16	①	Orange / white		CTRL IN 9
	②	Orange		CTRL IN 10
	③	Green / white		CTRL IN 11
	④	Blue		CTRL IN 14
	⑤	Blue / white		CTRL IN 13
	⑥	Green		CTRL IN 12
	⑦	Brown / white		CTRL IN 15
	⑧	Brown		CTRL IN 16
	Shield	Shield		CTRL IN 9 – 16 Common*

\* Both Common terminals are factory-connected to the VX-2000's internal GND terminal.

*Continued on next page*

[VX-2000 Control output connection example]

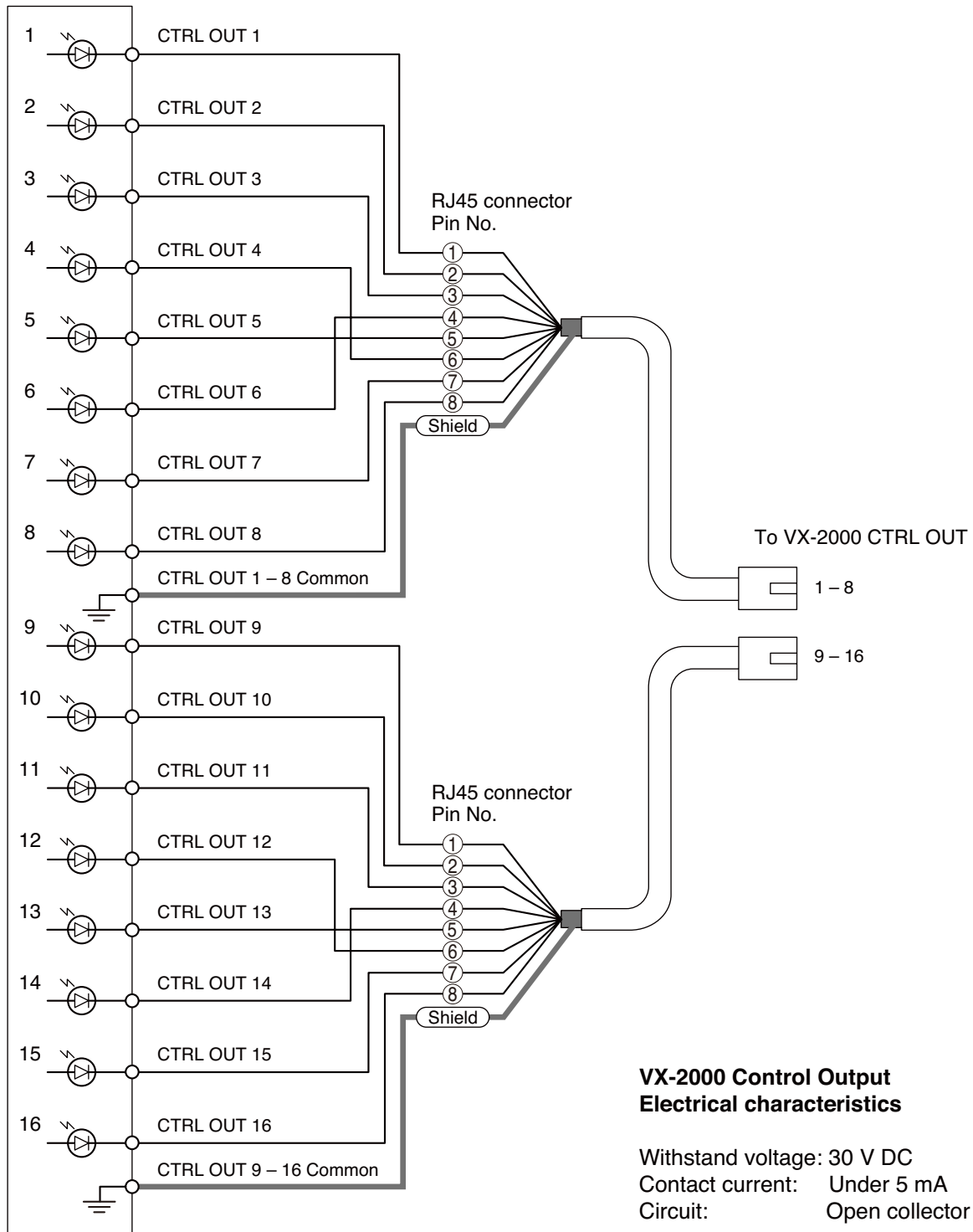

Because the VX-2000's control output uses photocouplers, it can be insulated by performing settings. Through these settings, CTRL OUT 1 – 8 Common terminal and CTRL OUT 9 – 16 Common terminal are disconnected from the VX-2000's internal GND terminal. (Refer to p. 8-17 for the setting procedure.)

### 6.6. VX-200SI Connections

Connector Name	RJ45 Pin No.	Colour	Pair	Assignment
CTRL IN 1 – 4	①	Orange / white		CTRL IN 1
	②	Orange		COM 1
	③	Green / white		CTRL IN 2
	④	Blue		COM 3
	⑤	Blue / white		CTRL IN 3
	⑥	Green		COM 2
	⑦	Brown / white		CTRL IN 4
	⑧	Brown		COM 4
	Shield	Shield		NC
CTRL IN 5 – 8	①	Orange / white		CTRL IN 5
	②	Orange		COM 5
	③	Green / white		CTRL IN 6
	④	Blue		COM 7
	⑤	Blue / white		CTRL IN 7
	⑥	Green		COM 6
	⑦	Brown / white		CTRL IN 8
	⑧	Brown		COM 8
	Shield	Shield		NC
CTRL IN 9 – 12	①	Orange / white		CTRL IN 9
	②	Orange		COM 9
	③	Green / white		CTRL IN 10
	④	Blue		COM 11
	⑤	Blue / white		CTRL IN 11
	⑥	Green		COM 10
	⑦	Brown / white		CTRL IN 12
	⑧	Brown		COM 12
	Shield	Shield		NC
CTRL IN 13 – 16	①	Orange / white		CTRL IN 13
	②	Orange		COM 13
	③	Green / white		CTRL IN 14
	④	Blue		COM 15
	⑤	Blue / white		CTRL IN 15
	⑥	Green		COM 14
	⑦	Brown / white		CTRL IN 16
	⑧	Brown		COM 16
	Shield	Shield		NC

Continued on next page

[VX-200SI connection example]

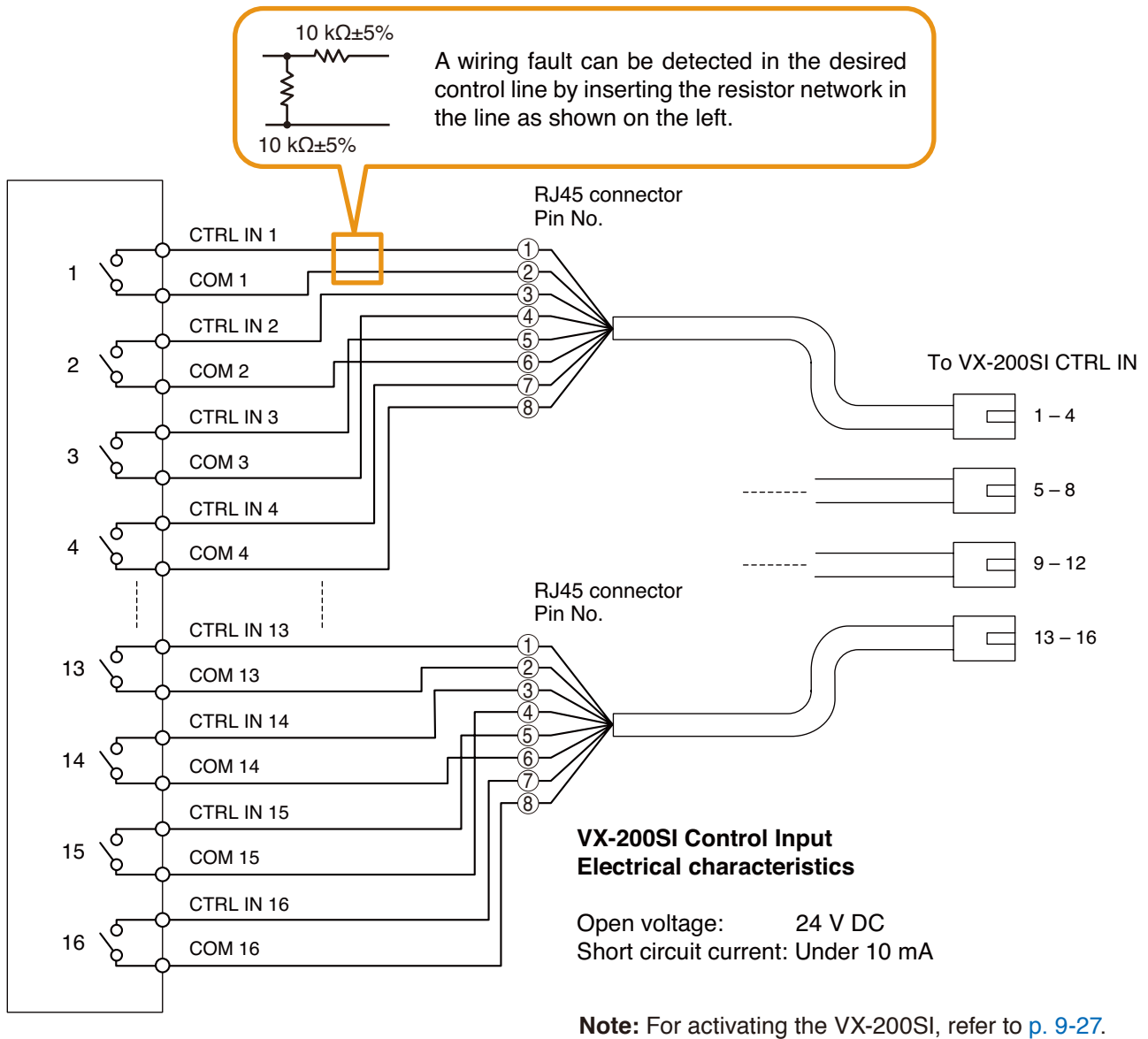

[Control line surveillance]

Function for detecting a wiring fault in the cable connected to the external control output device can be set to the control input terminals of the VX-200SI.

Connect the resistors to the cable of which fault is to be detected as shown above.

For the method of setting the fault detection function to the control input terminals, refer to p. 7-15.

**Notes**

- The wiring fault detection function will not work on the CTRL IN channels for which "Insulation setting" has been performed. (Refer to p. 8-32.)
- Be sure to connect the resistors as shown in the diagram above.  
If no resistors are connected or resistors other than specified are used, the fault detection function will not work correctly.
- To assure stable operation of this wiring fault detection, it is recommended to use a shielded twisted pair cable of 10 m or less.
- Be sure to connect each shield wire to the functional ground terminal of each device.

**[VX-200SI's CTRL 1 – 4 terminals insulation]**

The VX-200SI's CTRL 1 – 4 terminals can be insulated by performing settings to be externally powered. (Refer to p. 8-32 for the setting procedure.)

Connector Name	RJ45 Pin No.	Colour	Pair	Assignment
CTRL IN 1 – 4	①	Orange / white	1-2	CTRL IN 1
	②	Orange		COM 1
	③	Green / white	3-6	CTRL IN 2
	④	Blue		COM 3
	⑤	Blue / white	4-5	CTRL IN 3
	⑥	Green		COM 2
	⑦	Brown / white	7-8	CTRL IN 4
	⑧	Brown		COM 4
	Shield	Shield		NC

• Connection example of the VX-200SI's CTRL 1 – 4 terminals

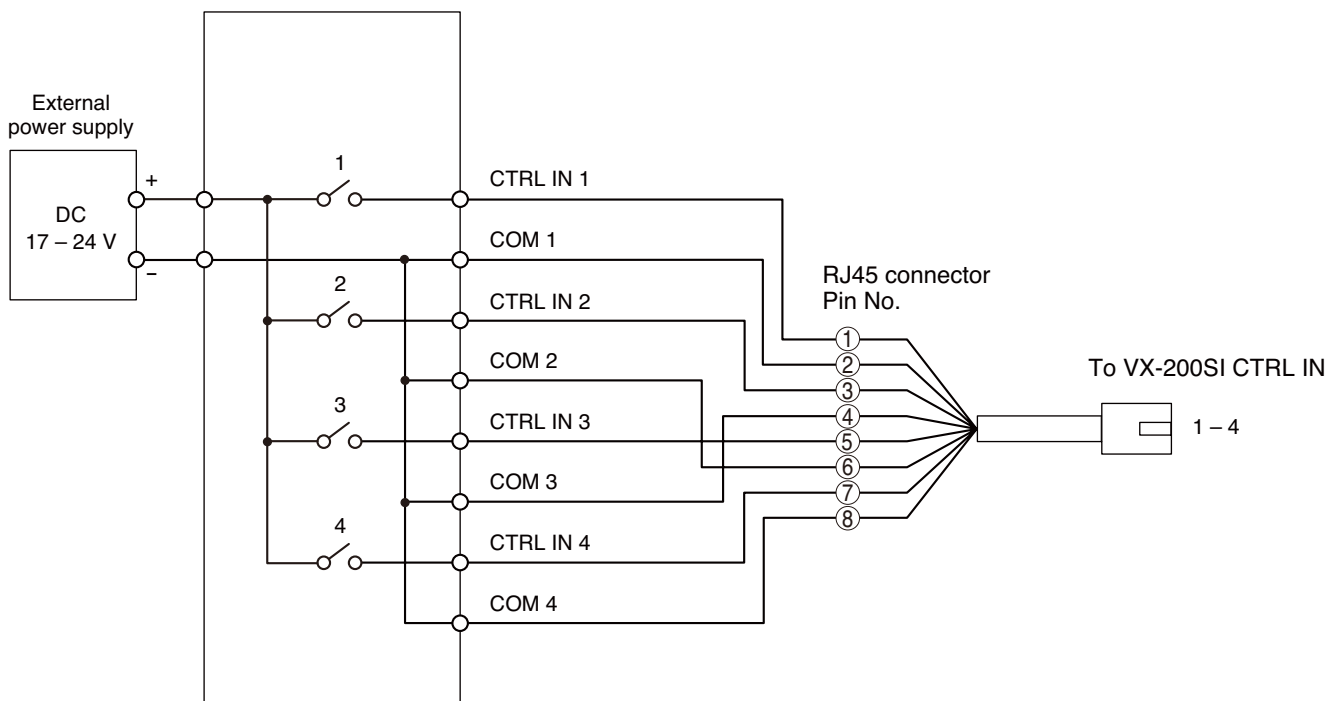

**VX-200SI Control Input 1 – 4 (photocoupler-insulated)  
Electrical characteristics**

Voltage requirement: 17 – 24 V DC  
Short circuit current: Under 10 mA  
Control current: 4 – 5 mA

**Note:** For activating the VX-200SI, refer to p. 9-27.

### 6.7. VX-200SO Connections

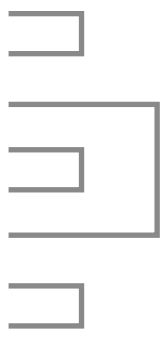
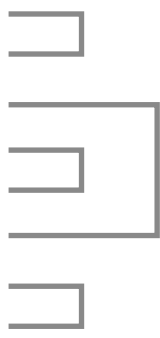
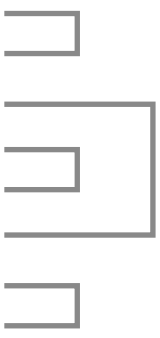
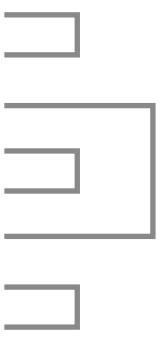
Connector Name	RJ45 Pin No.	Colour	Pair	Assignment
CTRL IN 1 – 4	①	Orange / white		CTRL OUT 1
	②	Orange		COM 1
	③	Green / white		CTRL OUT 2
	④	Blue		COM 3
	⑤	Blue / white		CTRL OUT 3
	⑥	Green		COM 2
	⑦	Brown / white		CTRL OUT 4
	⑧	Brown		COM 4
	Shield	Shield		NC
CTRL IN 5 – 8	①	Orange / white		CTRL OUT 5
	②	Orange		COM 5
	③	Green / white		CTRL OUT 6
	④	Blue		COM 7
	⑤	Blue / white		CTRL OUT 7
	⑥	Green		COM 6
	⑦	Brown / white		CTRL OUT 8
	⑧	Brown		COM 8
	Shield	Shield		NC
CTRL IN 9 – 12	①	Orange / white		CTRL OUT 9
	②	Orange		COM 9
	③	Green / white		CTRL OUT 10
	④	Blue		COM 11
	⑤	Blue / white		CTRL OUT 11
	⑥	Green		COM 10
	⑦	Brown / white		CTRL OUT 12
	⑧	Brown		COM 12
	Shield	Shield		NC
CTRL IN 13 – 16	①	Orange / white		CTRL OUT 13
	②	Orange		COM 13
	③	Green / white		CTRL OUT 14
	④	Blue		COM 15
	⑤	Blue / white		CTRL OUT 15
	⑥	Green		COM 14
	⑦	Brown / white		CTRL OUT 16
	⑧	Brown		COM 16
	Shield	Shield		NC

Continued on next page

[VX-200SO connection example]

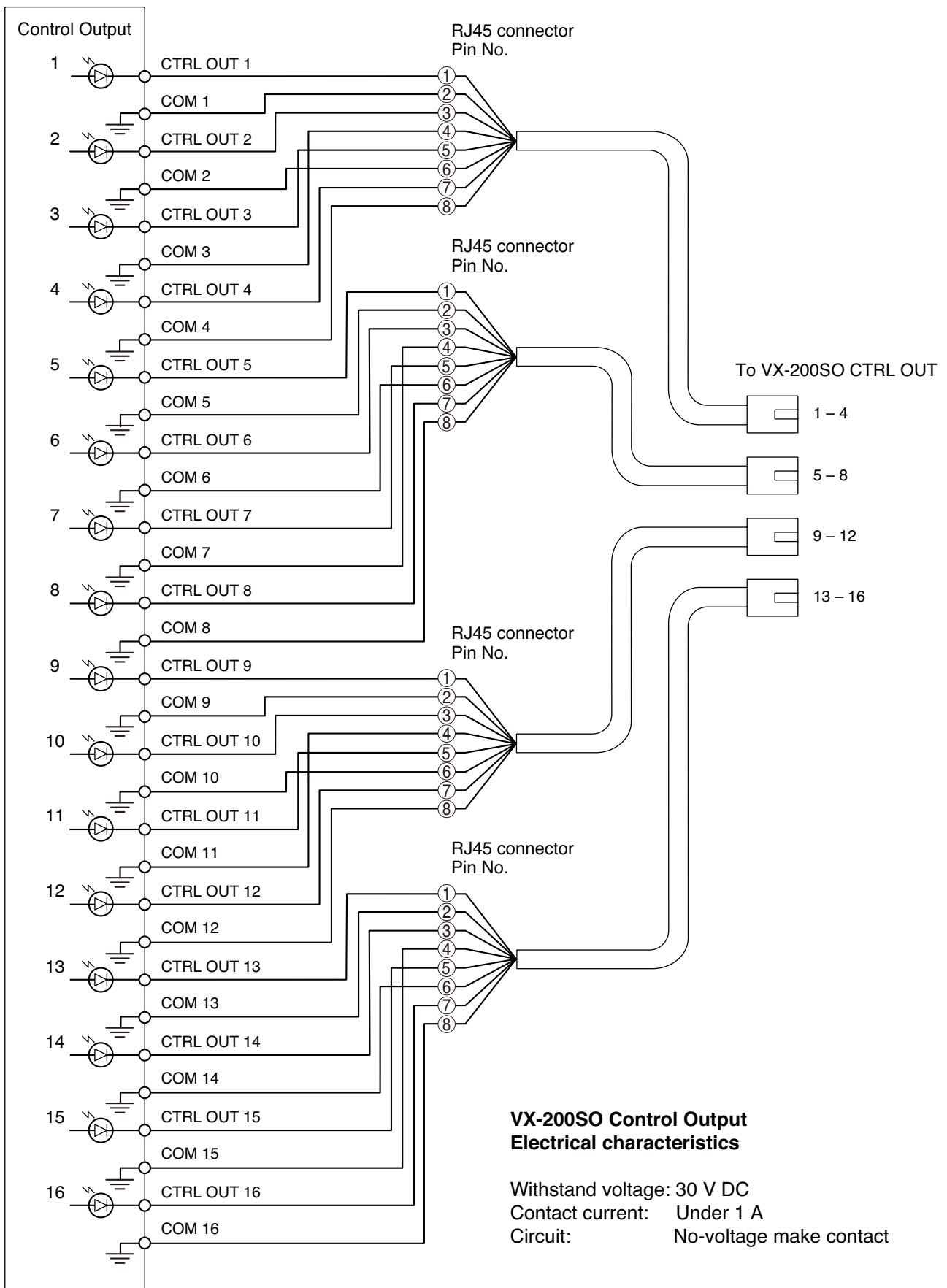



## 7. CABLE DISTANCE BETWEEN COMPONENTS

### 7.1. VX-2000 to Remote Microphone Cable Distance

The cable distance between Remote Microphones (RM-200X or RM-200XF) is determined by the specifications of the LONWORKS' Twisted Pair Free Topology Network (assuming Cat. 5 STP cable is used).

[Connection example and total cable distance]

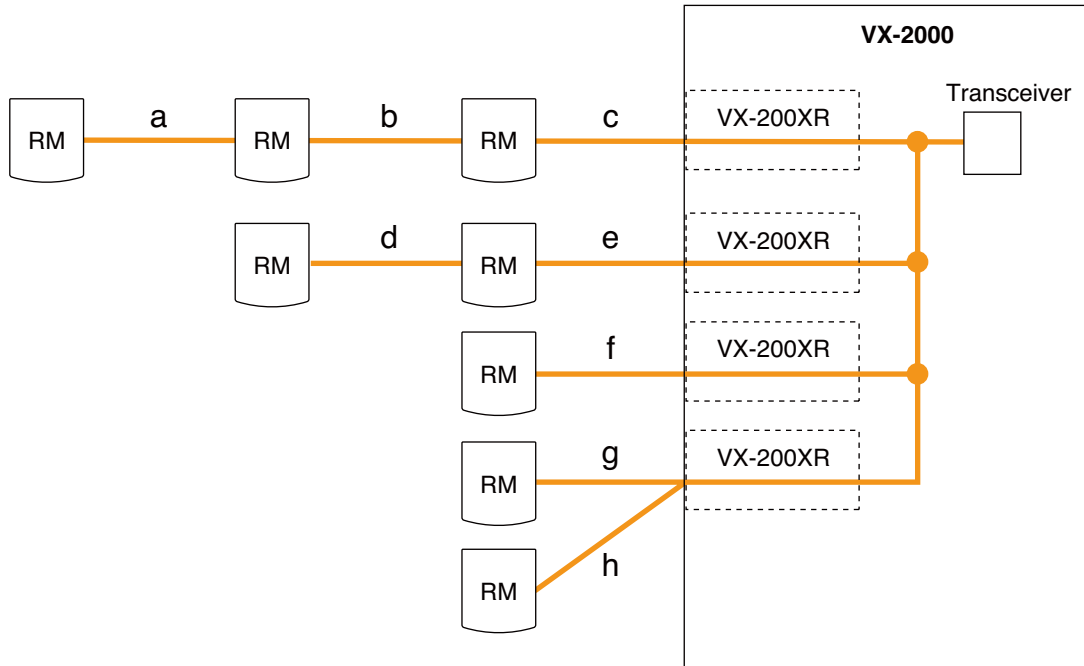

The maximum total cable length between all connected Remote Microphones and the VX-200XR is 450 m. However, the maximum length between individual components within the system is 250 m.

$$a + b + c + d + e + f + g + h \leq 450 \text{ m}$$

(a, b, c, d, e, f, g, and h: Individual connections  $\leq$  250 m)

#### Tips

Cable distances can be increased by changing the cable type.

Cable Type	Total Cable Distance	Maximum Cable Distance Between Components
Belden 85102	500 m	500 m
Belden 8471	500 m	450 m
Level IV, 22AWG	500 m	400 m
JY (St) Y 2 x 2 x 0.8	500 m	320 m
Cat. 5 STP	450 m	250 m

## 7.2. VX-200XR to Remote Microphone Cable Distance Extension

### 7.2.1. Mount the Repeater on the VX-200XR and set the Free Topology

This setting permits the cable length between the repeater-mounted VX-200XR and its connected Remote Microphones to be extended to up to 450 m (using Cat. 5 STP cable). (Refer to p. 9-37 for the setting procedure.)

#### [Connection example and total cable distance]

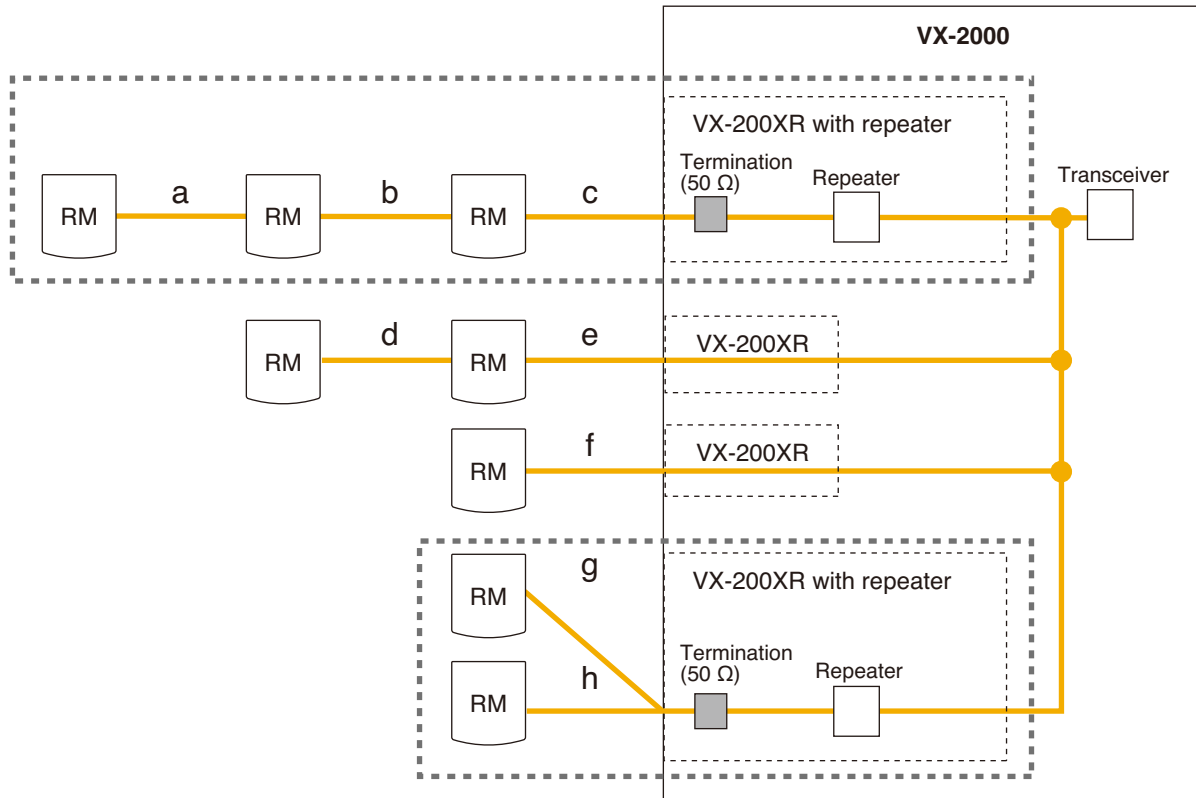

The total cable length between each repeater-mounted VX-200XR and its connected Remote Microphones can be individually extended up to 450 m.

$$a + b + c \leq 450 \text{ m (a, b, and c} \leq 250 \text{ m)}$$

$$g + h \leq 450 \text{ m (g and h} \leq 250 \text{ m)}$$

#### Tips

- In locations where this setting was performed, the total cable distance can be further increased by changing the cable type.

Cable Type	Total Cable Distance	Maximum Cable Distance Between Components
Belden 85102	500 m	500 m
Belden 8471	500 m	450 m
Level IV, 22AWG	500 m	400 m
JY (St) Y 2 x 2 x 0.8	500 m	320 m
Cat. 5 STP	450 m	250 m

- As for the VX-200XR without repeater, the total cable distance is based on the same idea as the previous section "9.1. VX-2000 to Remote Microphone Cable Distance."

The cable distance in the above example is expressed as follows when using Cat.5 STP cable for connection:  
 $d + e + f \leq 450 \text{ m (d, e, and f} \leq 250 \text{ m)}$

• Modifying the VX-200XR

[Required parts for modification (prepare separately)]

Parts	Quantity	Description
100 Ω resistor	1	1/4 W or 1/5 W, 5 mm pitch Equivalent to TOA part code: 112-31-041-10 (R25 100 Ω 5%) or TOA part code: 112-71-025-70 (R20 100 Ω 5%)
FTT-10A	2	Twisted pair free topology transceiver TOA part code: 111-31-281-60
Crystal oscillator	1	3 pins (1: Vcc, 2: GND, 3: OUT), 2.5 mm pitch Equivalent to TOA part code: 115-46-055-50 (JXO-5 10.00 MHz) A crystal oscillator of 5 MHz may be used.

[Parts installation]

- Install these parts illustrated below:

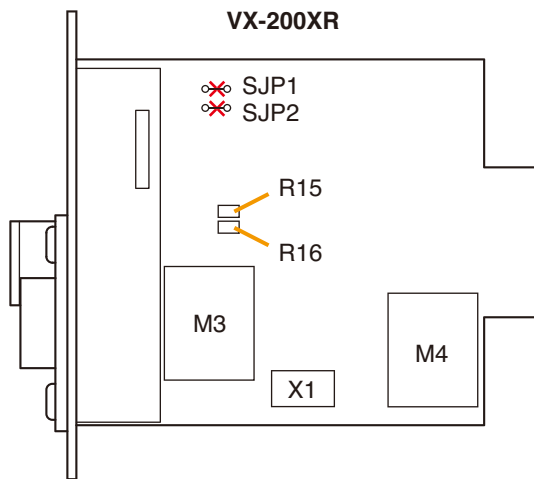

Designator	Description
R15	100 Ω resistor
R16	100 Ω resistor
M3	FTT-10A
M4	FTT-10A
X1	Crystal oscillator

- Cut SJP1 and SJP2 with nippers or other cutters.

### 7.2.2. Mount the Repeater on the VX-200XR and set the Doubly Terminated Bus Topology

Also attach a 100 Ω terminating resistor to the furthest distant Remote Microphone.  
This setting permits the total cable length between the Remote Microphones and the repeater-mounted VX-200XR to be extended to up to 900m (using Cat. 5 STP cable).  
(Refer to p. 9-39 for the setting procedure.)

#### [Connection example and total cable distance]

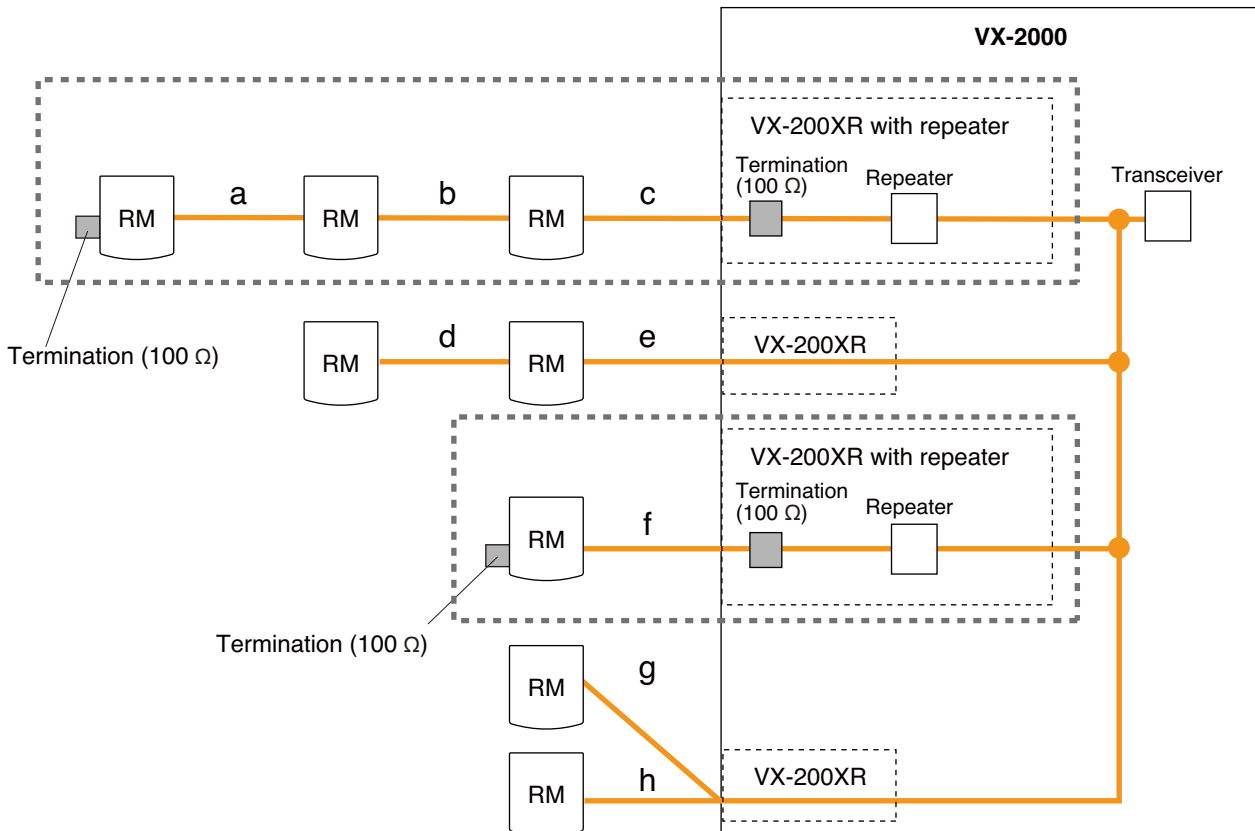

Total cable length between each repeater-mounted VX-200XR and its connected Remote Microphones can be extended to up to 900 m. In this cable extension method, there is no limitation to the maximum cable distance between components.

$$a + b + c \leq 900 \text{ m}$$

$$f \leq 900 \text{ m}$$

#### Example

All cable type can be extended up to 900 m.

Cable Type	Total Cable Distance
Belden 85102	900 m
Belden 8471	900 m
Level IV, 22AWG	900 m
Cat. 5 STP	900 m

If you need more extension, please contact your nearest TOA dealer.

• Modifying the VX-200XR

[Required parts for modification (prepare separately)]

Parts	Quantity	Description
100 Ω resistor	1	1/4W or 1/5W, 5 mm pitch Equivalent to TOA part code: 112-31-041-10 (R25 100 Ω 5%) or TOA part code: 112-71-025-70 (R20 100 Ω 5%)
FTT-10A	2	Twisted pair free topology transceiver TOA part code: 111-31-281-60
Crystal oscillator	1	3 pins (1: Vcc, 2: GND, 3: OUT), 2.5 mm pitch Equivalent to TOA part code: 115-46-055-50 (JXO-5 10.00 MHz) A crystal oscillator of 5 MHz may be used.

[Parts installation]

- Install these parts as illustrated below:

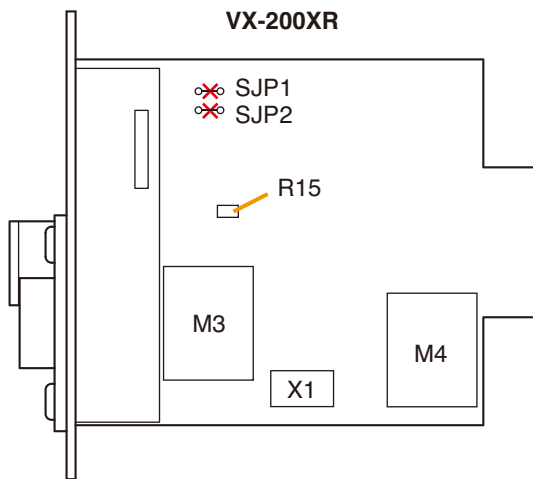

Designator	Description
R15	100 Ω resistor
M3	FTT-10A
M4	FTT-10A
X1	Crystal oscillator

- Cut SJP1 and SJP2 with nippers or other cutters.

• **Mounting a terminator on the RM-200XF**

The following 2 methods are available to terminate the RM-200XF: Internal switch setting and External resistor mounting.  
Be sure to perform either method because doing both methods may cause system malfunction.

**[Setting inside the RM-200XF]**

**Step 1.** Unscrew the RX-200XF's bottom plate.

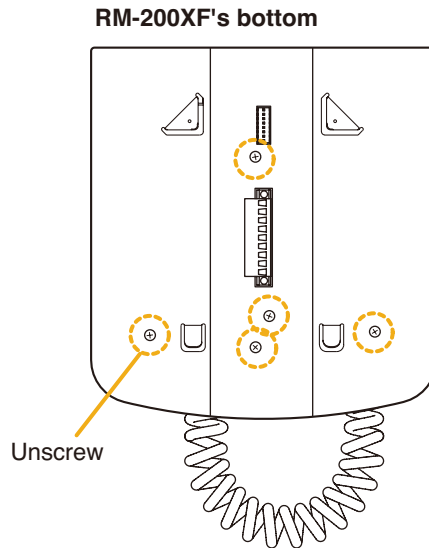

**Step 2.** Unplug the jumper socket connected across the pins 2 and 3. Then, plug it again into Pins.

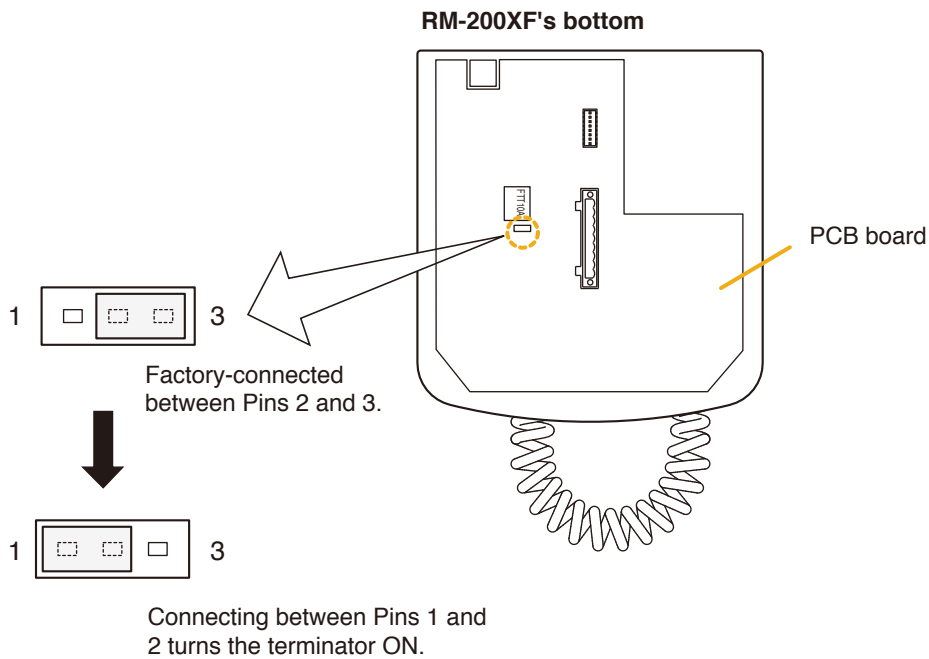

**Step 3.** Replace the removed plate.

**[Mounting a resistor to the plug-in screw terminal]**

Prepare the following part separately.

Parts	Quantity	Description
100 Ω resistor	1	1/4 W or 1/5 W Equivalent to TOA part code: 112-31-041-10 (R25 100 Ω 5%) or TOA part code: 112-71-025-70 (R20 100 Ω 5%)

Connect a resistor of 100 Ω across the RM data terminals together with connection cables as show below.

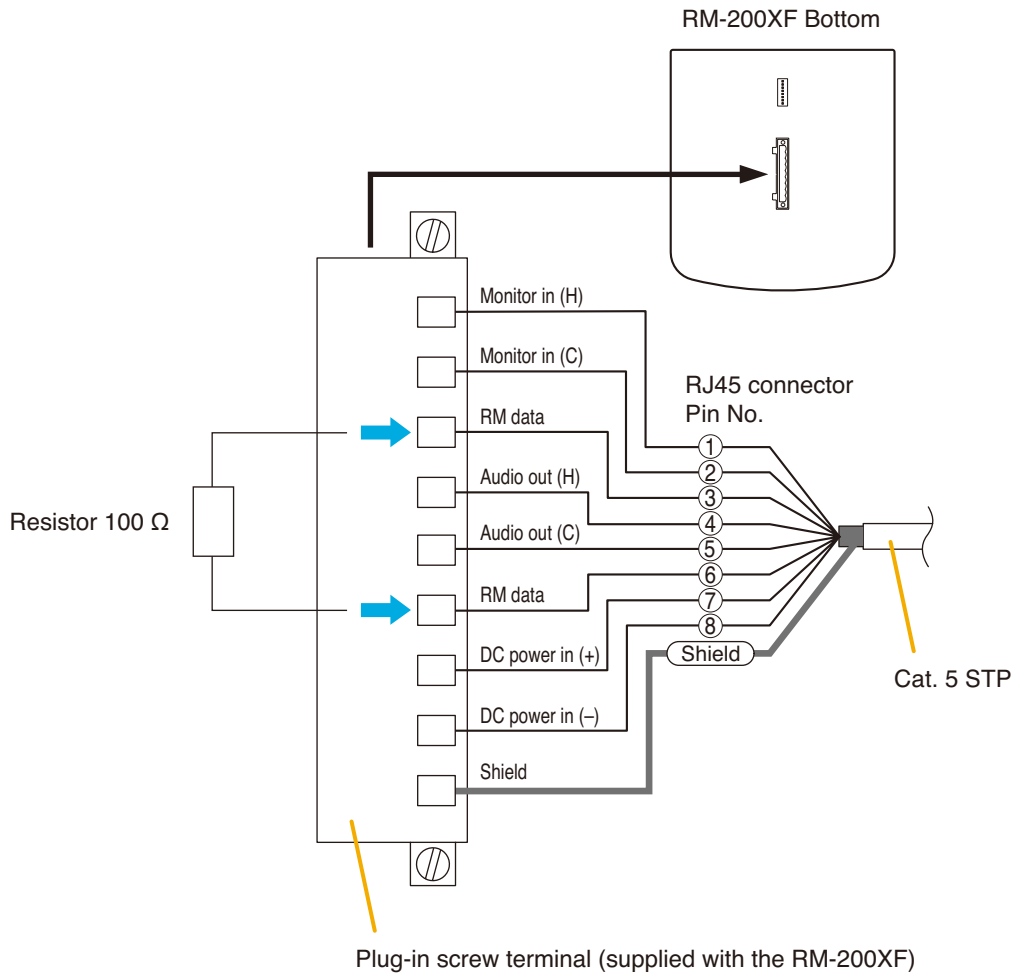

• **Mounting a terminator on the RM-200X**

The RJ45 male connector needs to be arranged for use as a terminator referring to the procedure below. All the parts used here should be prepared locally. As for a 100 Ω resistor among the parts, it is available as a service part as follows.

Parts	Quantity	Description
100 Ω resistor	1	1/4 W or 1/5 W Equivalent to TOA Part Code 112-31-041-10 (R25 100 Ω 5%) or TOA Part Code 112-71-025-70 (R20 100 Ω 5%)

**Step 1.** Fasten Cat.5 cable's inner wires in Pins 3 and 6 of the RJ45 male connector using a crimp tool.

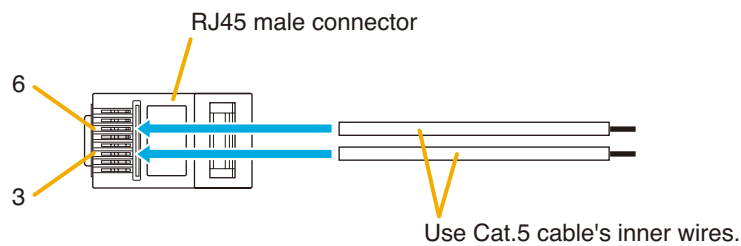

**Step 2.** Solder a 100 Ω resistor to the ends of both cables.

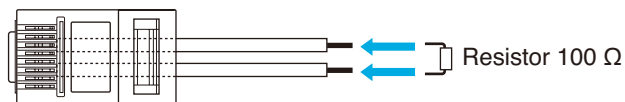

**Step 3.** Mount a protective modular cover onto the connector.

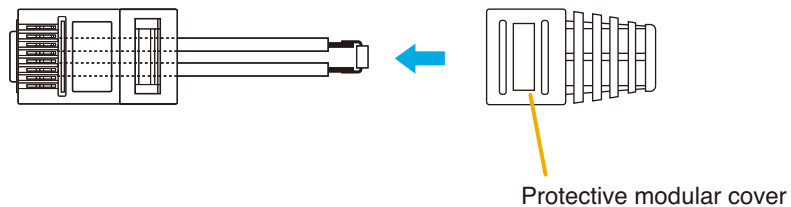

**Step 4.** Plug the assembled terminator into the RM-200X's LINK connector not in use.

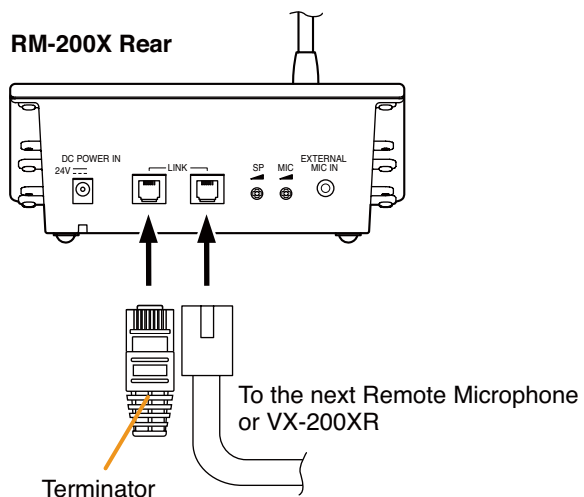

**Note**  
Mount the terminator on the last RM-200X connected only to the modified VX-200XR for doubly terminated bus topology.



### 7.3. Cable Distance between the VX-2000 and VX-2000SF

Cables connecting the VX-2000 data link connector to the VX-2000SF data link connector can be extended to up to 800 m in total (using Cat. 5 STP cable).

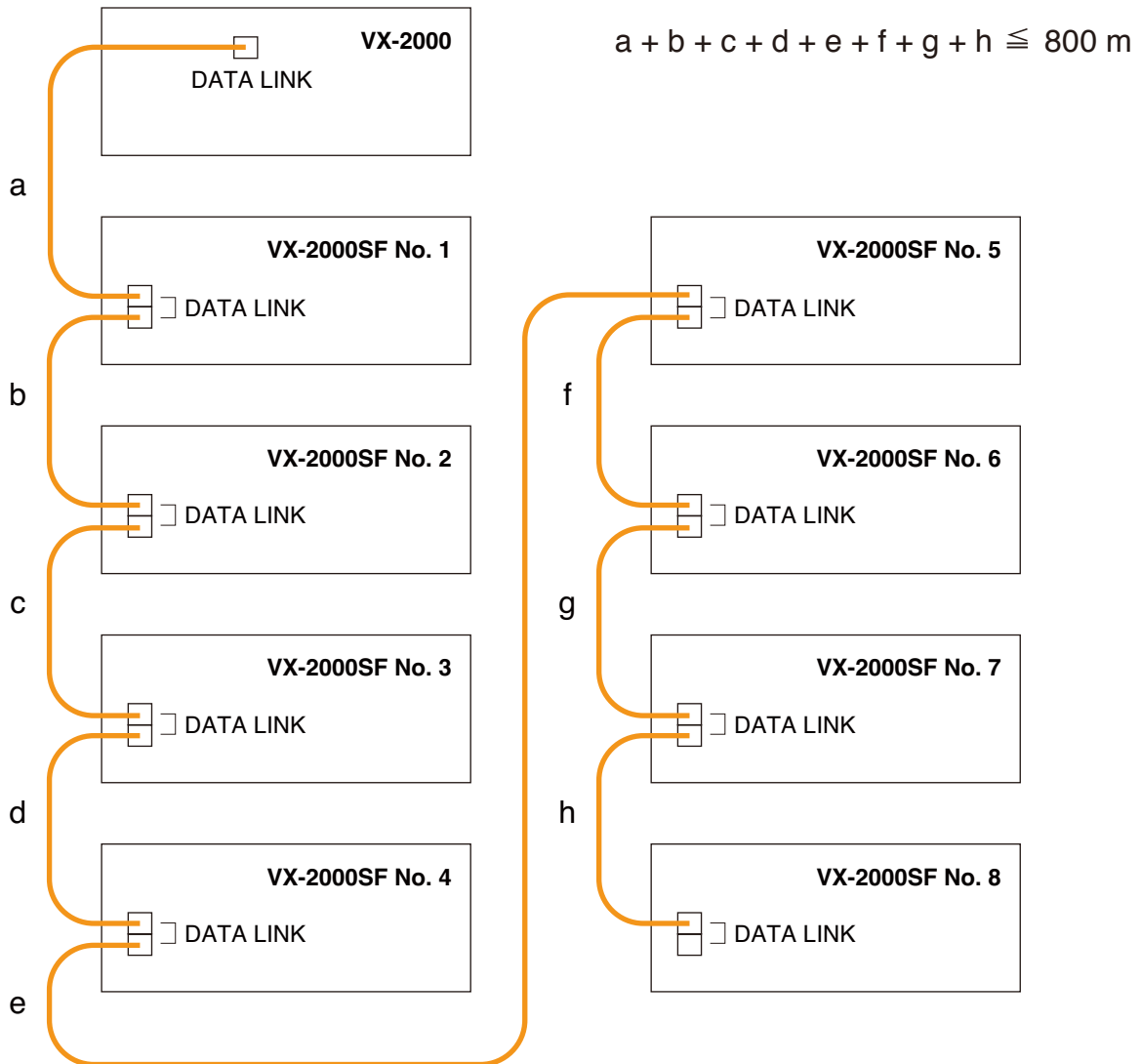

**Note**

Turn ON the terminator of the VX-2000SF connected last using the unit's front-mounted setting DIP switch. For setting the terminator, refer to [p. 8-26](#).

# ***Chapter 10***

---

## ***PC ONLINE CHECKS AND ADJUSTMENTS***

# 1. SYSTEM SETUP PROCEDURE

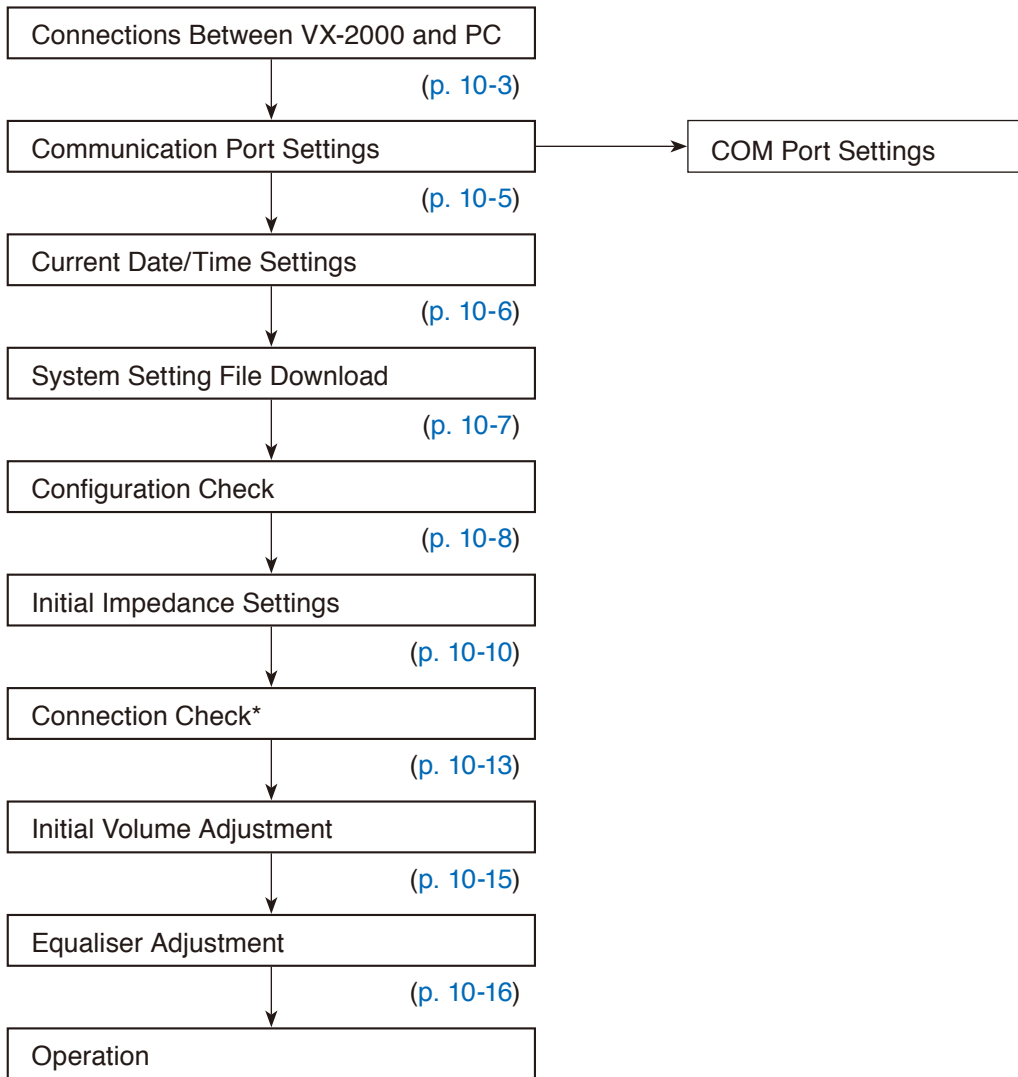

\* This function applies to the VX-2000 Setting Software Version 2.0 or later.

## 2. SYSTEM SETTING FILE DOWNLOAD

### 2.1. Connections between VX-2000 and PC

**Step 1.** Open the pocket in the VX-2000's front panel.

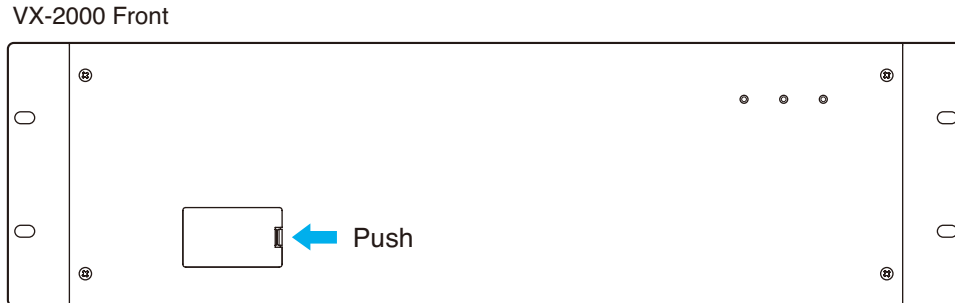

**Step 2.** Connect the PC to the VX-2000's RS-232C connector using a cross cable.

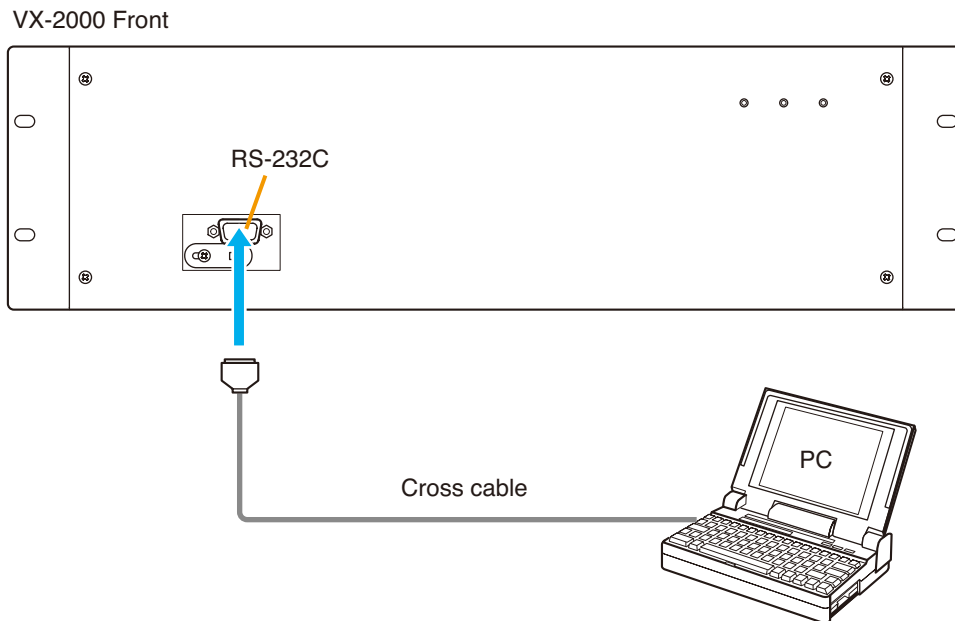

[Cross cable connection diagram]

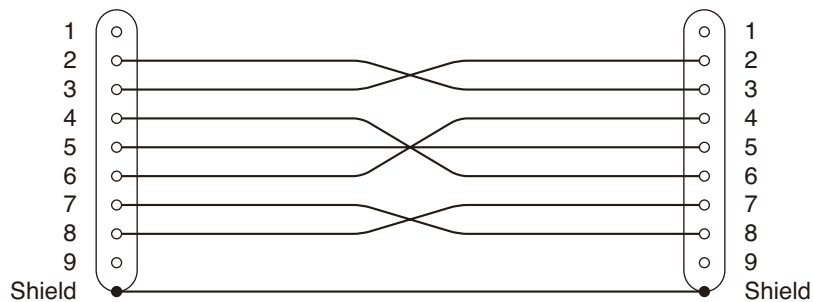

**Step 3.** Start the VX-2000 Setting Software, and open the prepared setting data file.

## 2.2. VX-2000 Setting Software Activation

Select [VX-2000 → VX-2000 setting software] from the Windows start menu.  
The VX-2000 setting software will be activated.

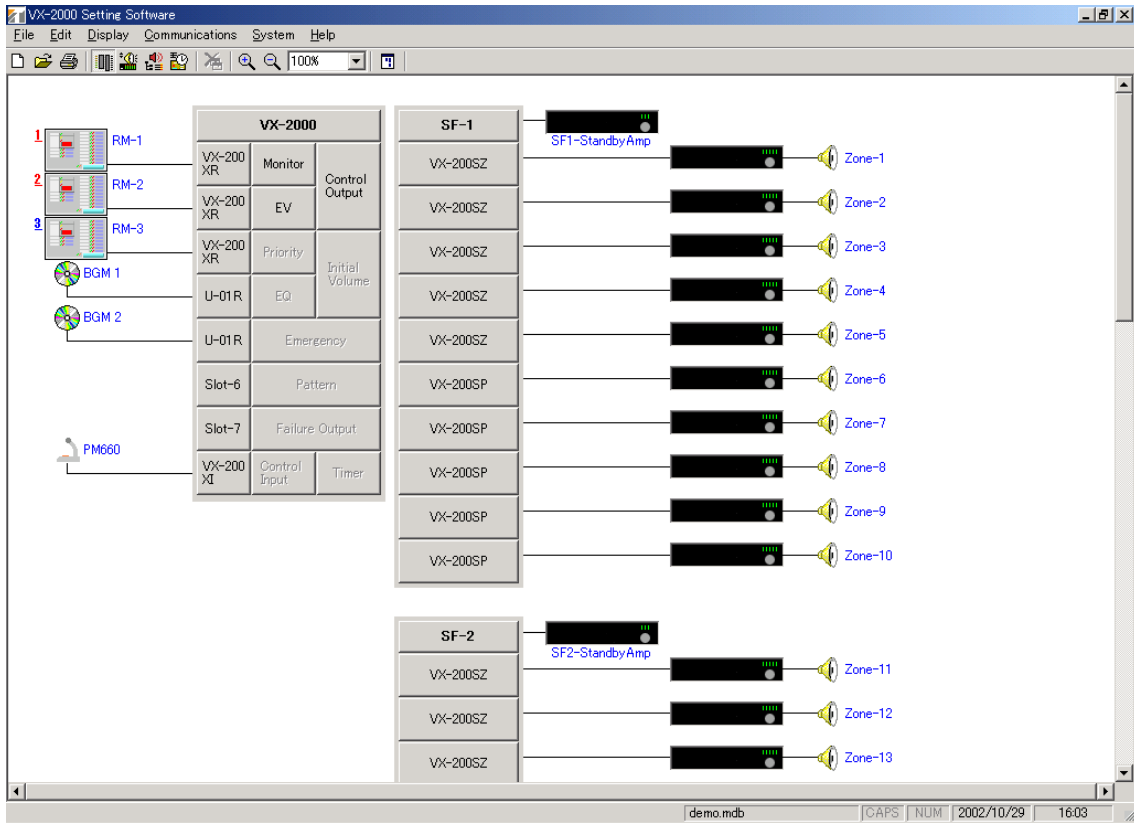

## 2.3. General Settings

Select [System → General Settings] from the menu to open the [General Settings] window.

Set the time and date for the VX-2000's internal timer, and select the PC COM port. The COM port is set to COM 1 by default. If the COM port setting needs to be changed, see the next section "2.3.1. Communication Port Settings." If it does not need to be changed, refer to p. 10-6 "2.3.2. Current Date/Time Settings."

### 2.3.1. Communication Port Settings

When communication port setting is required, click on the [Communication Settings] tab and perform the required settings. The port is set to COM 1 by default. If this needs to be changed, select from COM 2 to COM 9 and set.

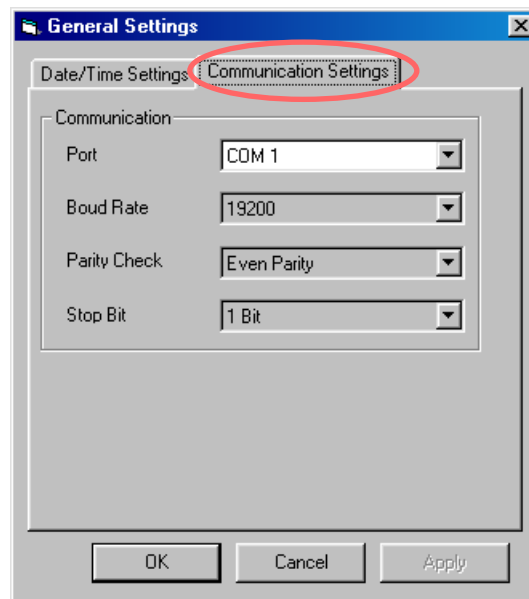

**Step 1.** Set the COM port.

Set the port from COM 1 to COM 9 in accordance with the communication port of the PC being used to control the VX-2000.

**Step 2.** Click on the [Apply] button to save the settings.

**Step 3.** Click on the [Date/Time Settings] tab.

Return to the [Date/Time Settings] window to perform the settings.

### 2.3.2. Current Date/Time Settings

Set the date and time for the VX-2000's internal timer.

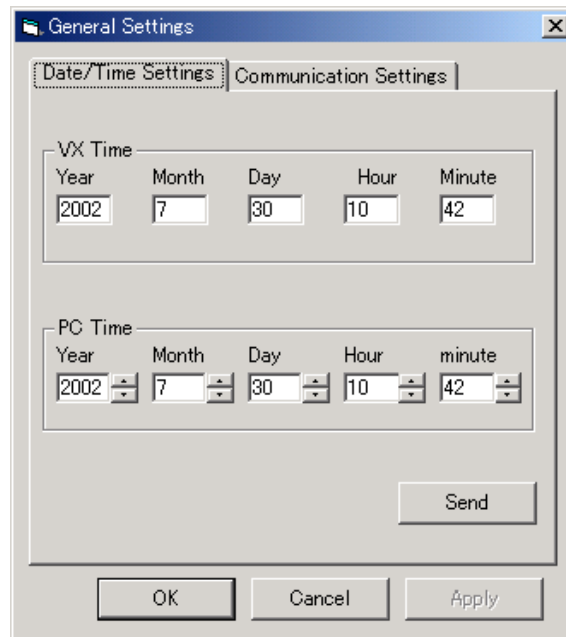

The VX-2000's internal timer settings are uploaded to the PC and displayed in the VX Time column.

**Step 1.** Set the current time in the VX-2000.

The displayed date and time in the PC Time column are those set in the PC.

If they are not correct, correct the PC Time setting by using up or down button of the item to be changed.

**Step 2.** Click on the [Send] button to transmit the PC Time setting to the VX-2000.

**Step 3.** After transmission completion, click on the [OK] button to close the [General Settings] window.

**Tip**

The set data/time settings are maintained for 7 days in case of power outage to the VX-2000.

## 2.4. System Setting File Download

Download the programmed system setting file from the PC to the VX-2000.

**Note:** The system setting file cannot be transferred while in the Emergency mode.

**Step 1.** Select [Communications → Download (PC → VX)] from the menu.

The following message will be displayed:

"All the data under setup is transmitted. Is communication started?"

**Step 2.** Click on the [OK] button to transmit the system setting file to the VX-2000.

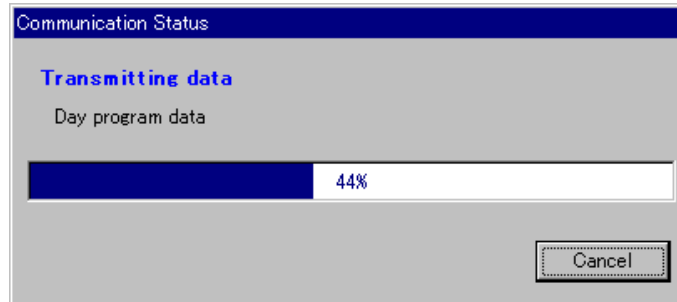

After the data transfer is 100% completed, the dialog box "Download was completed" will be displayed. When the [OK] button is pressed, the window closes, terminating the download.

### Tips

- No changes are made to the VX-2000 system setting file when communications are cancelled during the transmission.
- Whenever any system setting file is changed, be sure to perform downloading again.



## 3. SYSTEM CHECK FUNCTIONS

### 3.1. Configuration Check

This function confirms whether the system setting file set with a PC agrees with the actual equipment configuration.

**Note:** The configuration check function cannot be used while in emergency mode.

**Step 1.** Select [System → Configuration Check] from the menu.

The [System Configuration] window will open.

Equipment, modules, options, and other set equipment configurations are displayed in the "PC Data" column.

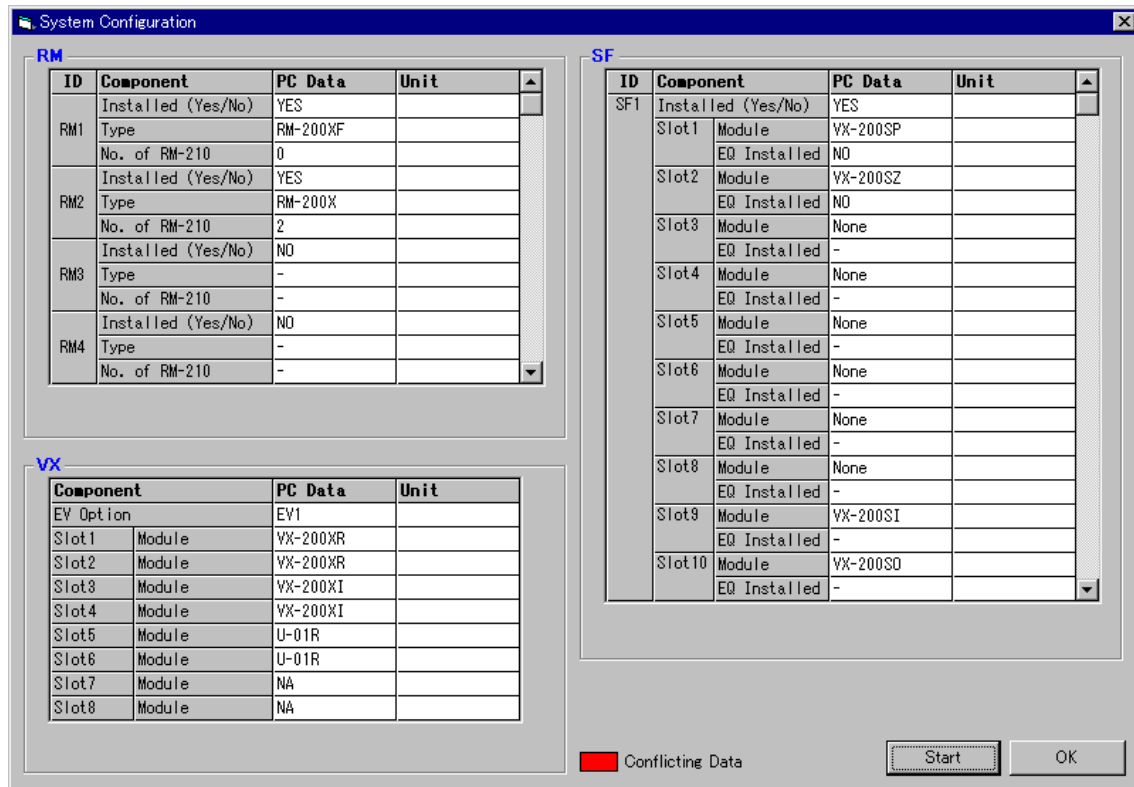

**Step 2.** Click on the [Start] button.

Configuration check will start.

*Continued on next page*

**Step 3.** Compare with actual equipment configurations.

After configuration check completion, the dialog box "Configuration check was completed." will be displayed. Press the [OK] button to close the dialog box.

The connected equipment is displayed in the "Unit" column. Data that differs in configuration between the system setting file and actual configuration are displayed in red (Conflicting Data).

**System Configuration**

**RM**

ID	Component	PC Data	Unit
	Installed (Yes/No)	YES	YES
RM1	Type	RM-200XF	RM-200XF
	No. of RM-210	0	0
	Installed (Yes/No)	YES	YES
RM2	Type	RM-200X	RM-200X
	No. of RM-210	2	2
	Installed (Yes/No)	<b>YES</b>	<b>NO</b>
RM3	Type	<b>RM-200X</b>	-
	No. of RM-210	<b>0</b>	-
	Installed (Yes/No)	NO	NO
RM4	Type	-	-
	No. of RM-210	-	-

No. of Conflicting Data = 3

**SF**

ID	Component	PC Data	Unit
SF1	Installed (Yes/No)	YES	YES
Slot1	Module	VX-200SP	VX-200SP
	EQ Installed	NO	NO
Slot2	Module	VX-200SZ	VX-200SZ
	EQ Installed	NO	NO
Slot3	Module	None	None
	EQ Installed	-	-
Slot4	Module	None	None
	EQ Installed	-	-
Slot5	Module	None	None
	EQ Installed	-	-
Slot6	Module	None	None
	EQ Installed	-	-
Slot7	Module	None	None
	EQ Installed	-	-
Slot8	Module	None	None
	EQ Installed	-	-
Slot9	Module	VX-200SI	VX-200SI
	EQ Installed	-	-
Slot10	Module	VX-200SO	VX-200SO
	EQ Installed	-	-

No. of Conflicting Data = 0

**VX**

Component	PC Data	Unit
EV Option	EY1	EY1
Slot1	Module	VX-200XR
Slot2	Module	VX-200XR
Slot3	Module	VX-200XI
Slot4	Module	VX-200XI
Slot5	Module	U-01R
Slot6	Module	U-01R
Slot7	Module	NA
Slot8	Module	NA

No. of Conflicting Data = 0

■ Conflicting Data

Start OK

**Step 4.** Should conflicting data be detected, either correct the system setting file and download the new settings to the VX-2000 or match the actual component configuration to the system setting file.

When any system setting file is changed, the revised data must be downloaded to the VX-2000 again in order to be valid. Press the [Start] button again and perform equipment configuration checks until the "Conflicting Data" indication disappears.

**Step 5.** After confirming that the system setting file match the actual configuration, click on the [OK] button and close the [System Configuration] window.

## 3.2. Initial Impedance Settings

### Notes

- The VX-200SZ Impedance Detection Module monitors speaker line impedance to detect shorts or open circuits in the lines. An initial impedance value is used as a reference to detect speaker line irregularities.
- Speaker line impedance tends to change over time, thus increasing any variation from the initial impedance value set at the time of installation, and possibly causing the VX-200SZ to detect a line failure even when the speaker line is functioning correctly. Especially during the first several months after installation, it is highly recommended that the reference impedance be monthly updated using the initial impedance setting procedure. Since then, be sure to periodically update the reference impedance at the time of routine maintenance.

The initial impedance setting determines the VX-200SZ's initial impedance value.  
The following methods can be used to set the initial impedance.

Sections Operated		Features
PC Software Menu Selection	Connection check* (Use this function when further checking connections after initial impedance settings at the time of initial installation. Refer to <a href="#">p. 10-13</a> .)	<ul style="list-style-type: none"> <li>• Initial impedance settings can be simultaneously performed for all VX-200SZ modules in the system.</li> <li>• Connection checks are made after initial impedance settings completion.</li> </ul>
	Initial Impedance Settings (Use this function only when setting the VX-200SZ's initial impedance value during periodic maintenance. Refer to <a href="#">p. 10-11</a> .)	<ul style="list-style-type: none"> <li>• Settings can be simultaneously performed for all VX-200SZ modules in the system.</li> <li>• Only the initial impedance settings are performed (no connection checks are made).</li> </ul>
VX-2000SF Initial Setting Switch (Refer to <a href="#">p. 10-12</a> .)		<ul style="list-style-type: none"> <li>• Enables the initial impedance settings for individual VX-2000SF units.</li> <li>• Does not need to be operated from a PC.</li> </ul>

\* This function applies to the VX-2000 Setting Software Version 2.0 or later.

### 3.2.1. Using the PC software initial impedance settings

Follow the steps in the procedure below to set the VX-200SZ's initial impedance value.

**Step 1.** Select [System → Initial Impedance Settings] from the menu.

The [Initial Impedance Settings] window will open.

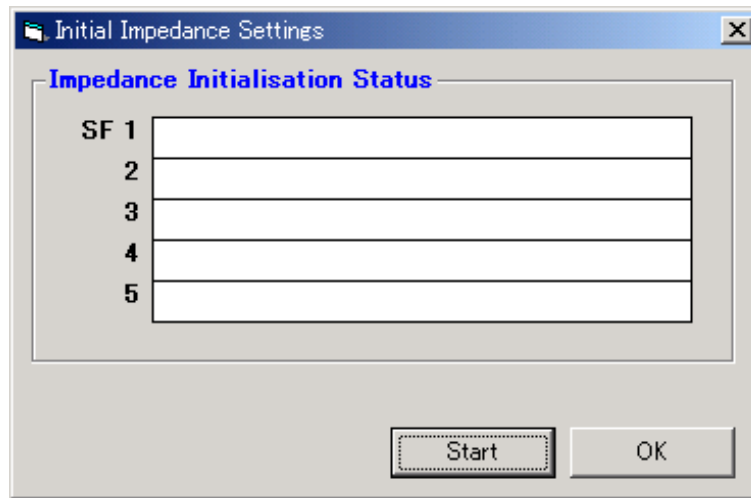

**Step 2.** Click on the [Start] button.

Initial impedance value setting will be performed for all VX-200SZ modules in the system. When the VX-2000SF is not used in the system or when a VX-200SZ is not mounted in the frame, the "No connection" indication will be displayed on the Impedance Initialisation Status screen.

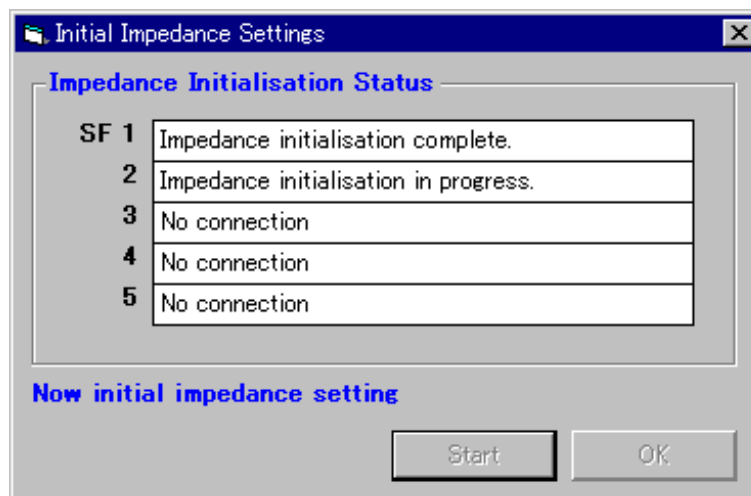

**Step 3.** Terminate the Initial Impedance Settings.

A dialog box with the message "Initial impedance settings was completed." will be displayed after completion of the initial impedance value setting.

Click on the [OK] button in the [Initial Impedance Settings] window to terminate the setting.

#### Note

If the indication "Impedance initialisation failed." is displayed on the [Impedance Initialisation Status] screen, there may be a faulty connection in the system. In such cases, find and correct the faulty connection and then re-perform the initialisation.

### 3.2.2. Using the VX-2000SF's initial setting switch

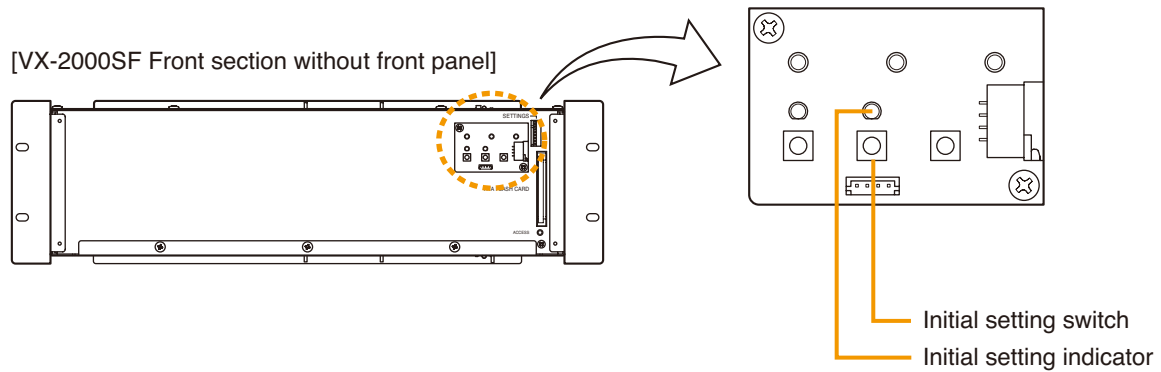

**Step 1.** Press the Initial setting switch.

The VX-200SZ's initial setting operation will start, and the VX-2000SF's Initial setting indicator will continuously light green during this period of time.

**Step 2.** Check to confirm that the Initial setting indicator is extinguished.

The Initial setting indicator automatically extinguishes upon completion of the initial setting.

**Note**

If the Initial setting indicator does not extinguish even after a lengthy period of time, there may be something wrong with the VX-200SZ. In such cases, please contact your nearest TOA dealer.

### 3.3. Connection Check

**Note:** This function applies to the VX-2000 Setting Software Version 2.0 or later.

After setting an initial impedance value for the VX-200SZ Impedance Detection Module mounted in the VX-2000SF Surveillance Frame, check to be sure that all cables between equipment components are connected correctly.

**Step 1.** Select [System → Connection Check] from the menu.

The [Connection Status] window will open.

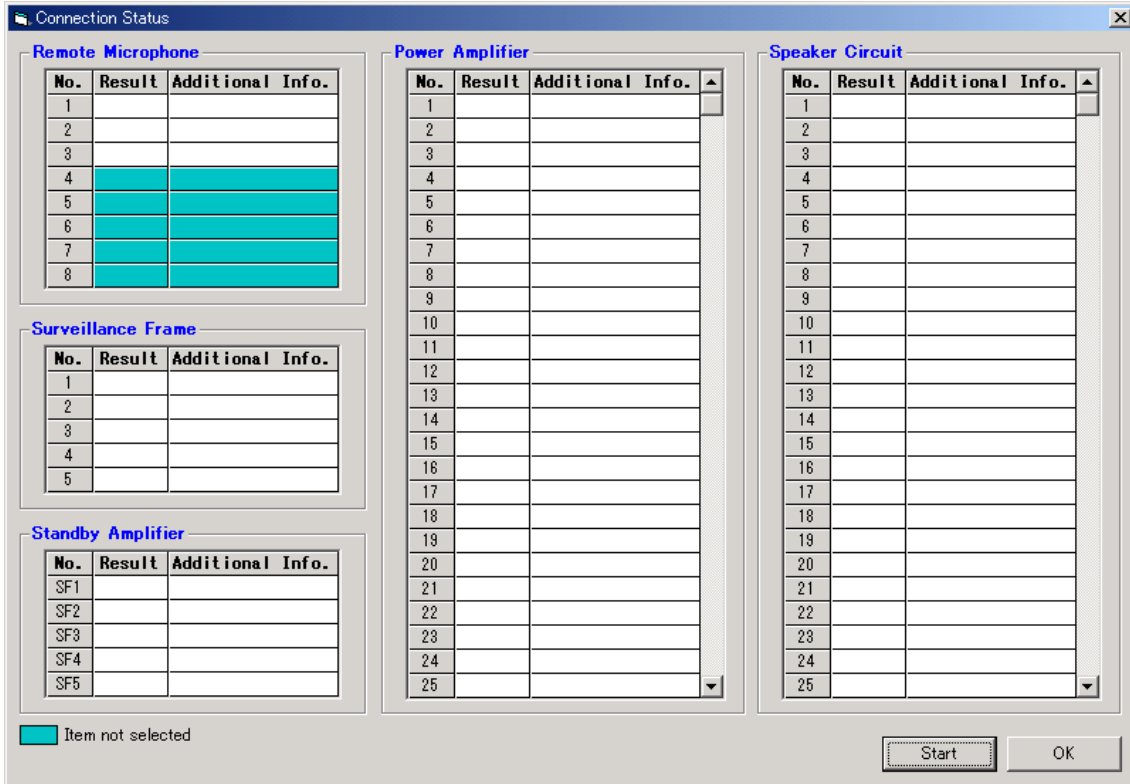

**Step 2.** Click the [Start] button.

The dialog box "Impedance initialisation is carried out before a connection check start." will be displayed.

Press the [OK] button.

The [Initial Impedance Settings] window will open, setting an initial impedance value for all of the VX-200SZ modules in the system.

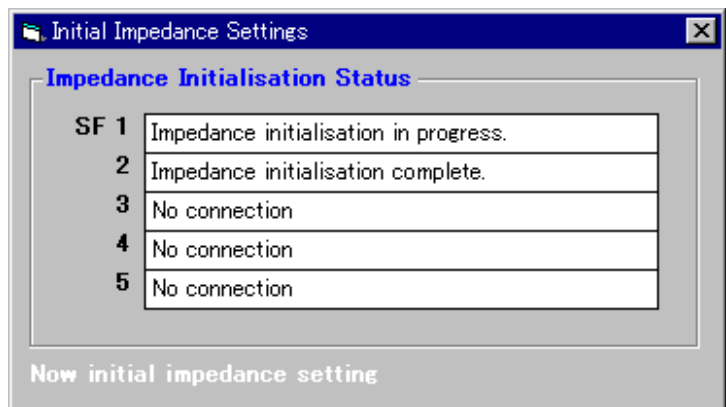

Initial impedance value setting will be performed for all VX-200SZ modules in the system. When the VX-2000SF frame is not used in the system or when a VX-200SZ is not mounted in the frame, the "No connection" will be displayed on the Impedance Initialisation Status screen.

#### Note

If the indication "Impedance initialisation failed." is displayed on the Impedance Initialisation Status screen, there may be a faulty connection in the system. In such cases, find and correct the faulty connection and then re-perform the initialisation.

Further continue to check connections, and reinitialise impedance after correcting connection errors.

**Step 3.** Check connections.

The dialog box "Initial impedance settings were completed." will be displayed after initialisation completion. Press the [OK] button. The dialog box will close and Connection Check will begin.

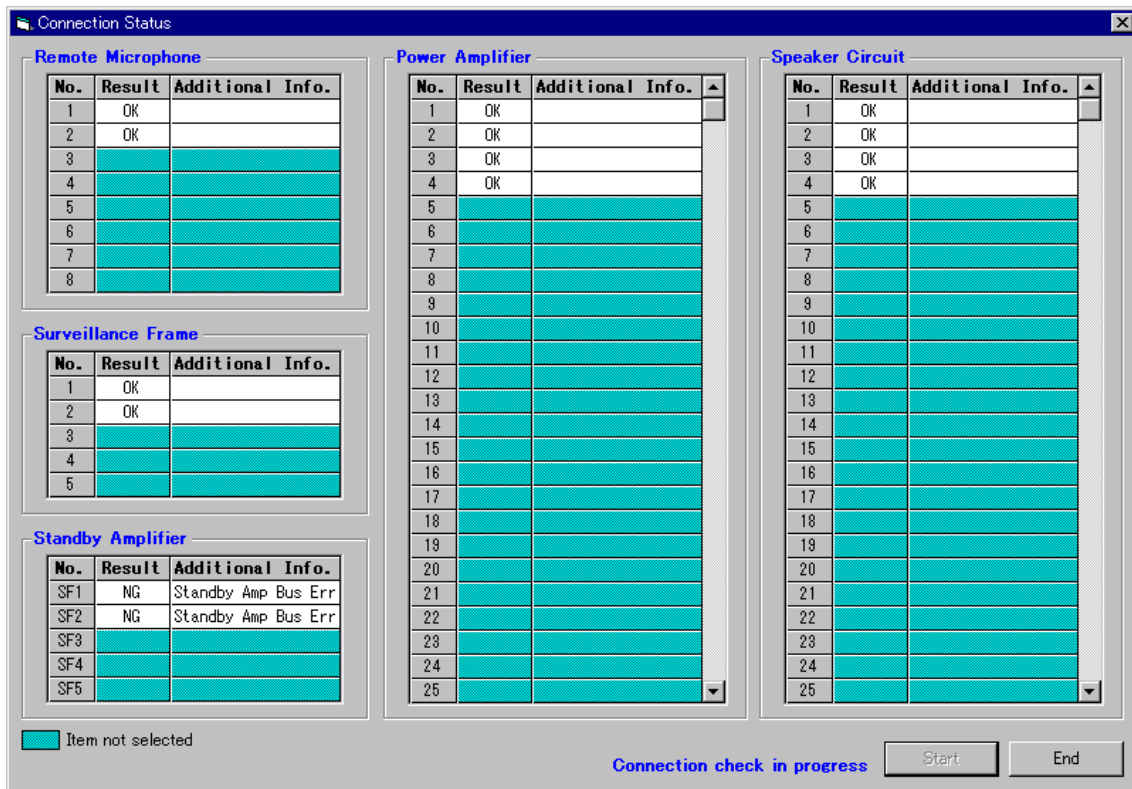

- After the connection check is complete, "OK" will be displayed in the "Result" column if all connections are determined to be correct, and "NG" when a problem has been detected. If "NG" is displayed, check the connections between equipment in question, and perform the connection check again.
- The Connection Check function continues operation until the [End] button is pressed. Pressing the [End] button stops the connection check operation. Operation can be resumed by pressing the [Start] button.
- Perform the connection check until the [OK] indication is displayed for all connections.

**Step 4.** After confirming that all connections are made correctly, press the [End] button to stop the connection check operation, then press the [OK] button to terminate the connection check.

**Notes**

- Should the indication "Impedance initialisation failed." be displayed in the Impedance Initial Settings, perform Connection Check again until [OK] is displayed for all connections in the "Result" column.
- When wishing to only set the VX-200SZ's initial impedance value, select [System → Initial Impedance Settings] from the menu.

## 4. VOLUME AND EQUALISER SETTINGS

When connected online, initial volume and equaliser settings can be varied using the PC software's "Send" function. This makes it possible to output sound and set the volume and equaliser to adequate initial levels during system installation.

### Note

The volume level and equaliser characteristics initially set using the software's "Send" function are reset when the system power is turned off. They return to the settings in the system setting file that was downloaded from a PC to the VX-2000 when the system power is turned on again.

After initial setting completion, download the changed system setting file to the VX-2000.

### 4.1. Initial Volume Settings

**Step 1.** Click on the [Initial Volume] button on the Configuration screen.

The [Initial Volume Settings] window will be displayed.

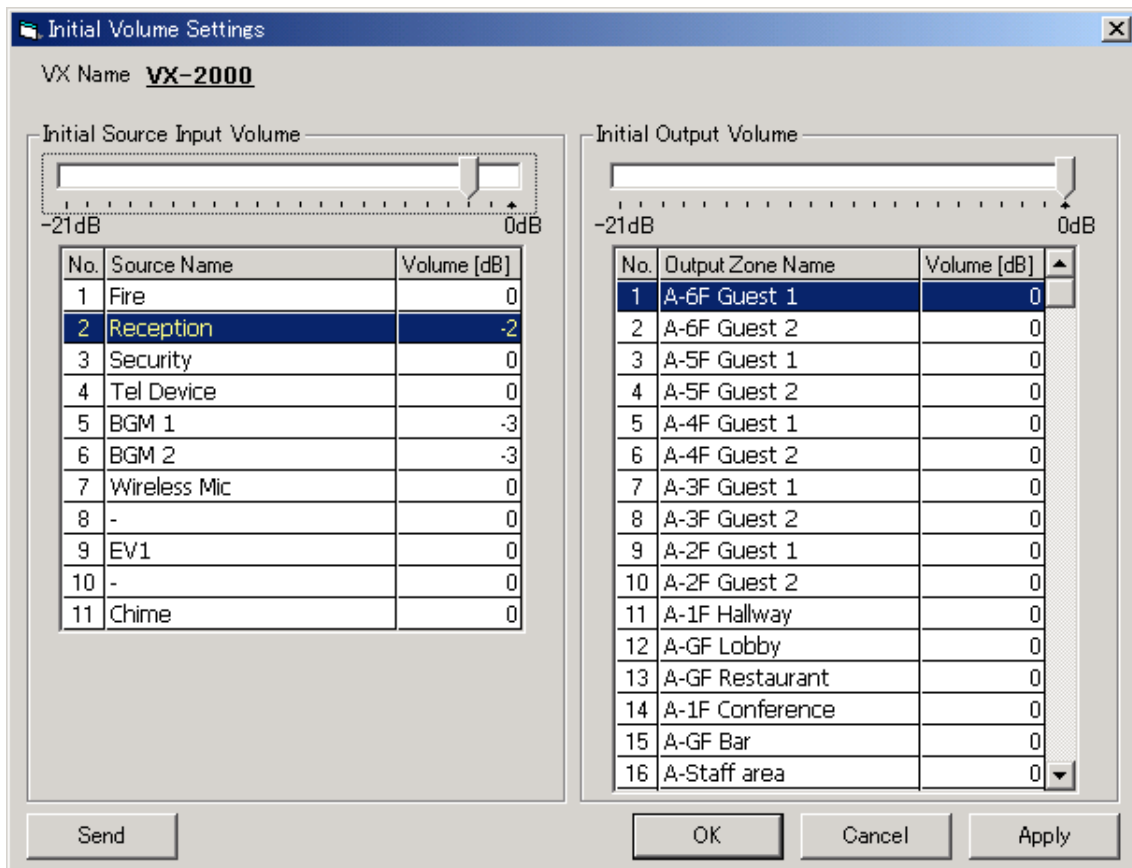

**Step 2.** Click on the name of the component for which the initial volume is to be set.

The sound volume can be set for 0 to -21 dB in 1 dB step.

This setting can also be performed by directly entering a numerical value in the volume cell.

**Step 3.** Click on the [Send] button and transmit the set value to the VX-2000.



## 4.2. Equaliser Settings

- Step 1.** Click on the [EQ] button on the Configuration screen.  
The [EQ Settings] window will be displayed.

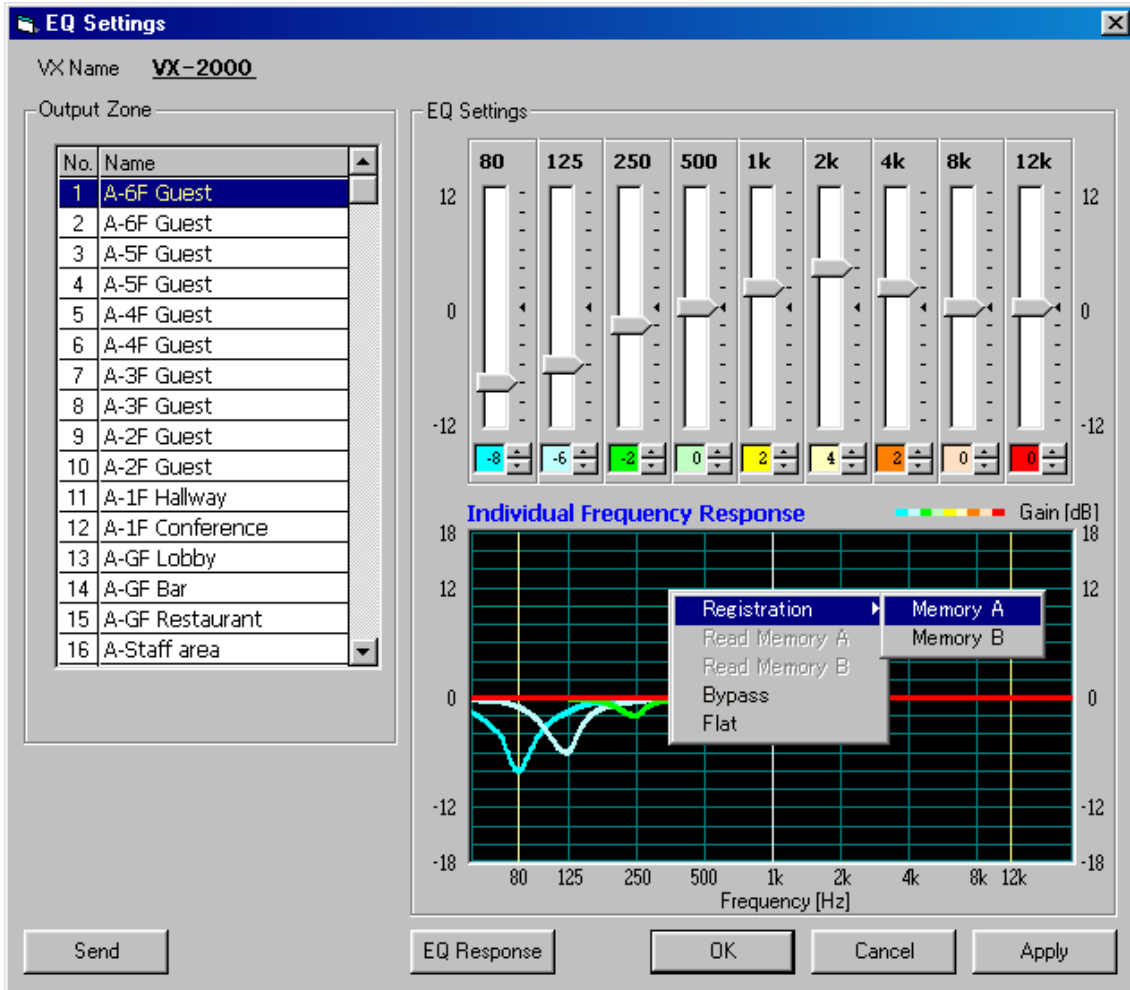

- Step 2.** Click on the name of the Output Zone for which the equalisation is to be set, and set the equaliser.  
The gain can be changed within  $\pm 12$  dB in 2 dB step.

- Step 3.** Click on the [Send] button and transmit the set value to the VX-2000.

### Note

The EQ settings also have a memory function with 2 storage settings: A and B. Optimum settings can be achieved by recalling Memory A or B and comparing its sound with the current settings. The floating menu shown superimposed over the frequency characteristics chart in the figure below is displayed when the right mouse button is clicked on the chart.

- Registration (Memory A, Memory B): Stores settings in either Memory A or B.
- Read Memory A: Recalls settings from Memory A.
- Read Memory B: Recalls settings from Memory B.
- Bypass: Bypasses the equaliser.
- Flat: Returns the equaliser settings to flat characteristics.

# ***Chapter 11***

---

## ***OTHER PC SOFTWARE FUNCTIONS***

# 1. MONITOR OPERATION CHECK

## Notes

- This function applies to the VX-2000 Setting Software Version 2.0 or later.
- Monitor Operation Check cannot be performed in emergency mode.

Whether or not the system's failure detection function is operating correctly can be checked through both manual and automatic inspections.

In automatic inspections, a failure is made to occur by stopping the generation of pilot tone to have it detected. In the manual inspection, cables are disconnected to have the disconnection detected.

**Step 1.** Select [System → Monitor Operation Check] from the menu.

The [Monitor Operation Check] window will open.

The items to be checked are classified by colour: Blue for automatic inspection and Yellow for manual inspection.

The inspection items are divided into 4 classifications of Equipment, Amplifier, Speaker, and Power Supply systems.

**Monitor Operation Check**

Equipment    Amplifier    Speaker    Power Supply

**Remote Microphone**

Item	1	2	3	4	5	6	7	8
Microphone	Automatic	Automatic	Automatic	Automatic	Automatic	Automatic	Automatic	Automatic
Audio Line	Automatic	Automatic	Automatic	Automatic	Automatic	Automatic	Automatic	Automatic
Microphone Key	Manual	Manual	Manual	Manual	Manual	Manual	Manual	Manual
Low Power Supply Voltage	Manual	Manual	Manual	Manual	Manual	Manual	Manual	Manual
RM Communication Error	Manual	Manual	Manual	Manual	Manual	Manual	Manual	Manual

**VX**

Item	Monitor Check
VX Internal Bus 1	Automatic
VX Internal Bus 2	Automatic
VX Internal Bus 3	Automatic
VX Internal Bus 4	Automatic
EV1 Failure	Manual
EV1 1kHz	Manual
EV2 Failure	Manual
EV2 1kHz	Manual

**SF**

Item	1	2	3	4	5
VX-SF Bus 1	Automatic	Automatic	Automatic	Automatic	Automatic
VX-SF Bus 2	Automatic	Automatic	Automatic	Automatic	Automatic
VX-SF Bus 3	Automatic	Automatic	Automatic	Automatic	Automatic
VX-SF Bus 4	Automatic	Automatic	Automatic	Automatic	Automatic
SF Bus Audio Switch 1	Automatic	Automatic	Automatic	Automatic	Automatic
SF Bus Audio Switch 2	Automatic	Automatic	Automatic	Automatic	Automatic
SF Bus Audio Switch 3	Automatic	Automatic	Automatic	Automatic	Automatic
SF Bus Audio Switch 4	Automatic	Automatic	Automatic	Automatic	Automatic
SF Bus Audio Switch 5	Automatic	Automatic	Automatic	Automatic	Automatic
SF Bus Audio Switch 6	Automatic	Automatic	Automatic	Automatic	Automatic
SF Bus Audio Switch 7	Automatic	Automatic	Automatic	Automatic	Automatic
SF Bus Audio Switch 8	Automatic	Automatic	Automatic	Automatic	Automatic
SF Bus Audio Switch 9	Automatic	Automatic	Automatic	Automatic	Automatic
SF Bus Audio Switch 10	Automatic	Automatic	Automatic	Automatic	Automatic
SF Communication Error	Manual	Manual	Manual	Manual	Manual

Automatic Inspection  
 Automatic Inspection (Not Set)  
 Manual Inspection  
 Manual Inspection (Not Set)

**Inspection Mode**

Automatic     Manual

Start    OK

*Continued on next page*

**Step 2.** Click on the [Start] button to start the Automatic monitor check.

In automatic inspections, by detecting a failure made to occur by stopping the generation of pilot tone, the failure detection circuit built in each equipment component can be checked that it operates properly. Detection results are displayed on the screen. An "NG" indication is displayed if inspected correctly.

### Note

Because the monitoring method for the RM-200X's microphone does not use the pilot tone, the microphone failure cannot be detected in automatic inspections.

**Remote Microphone**

Item	1	2	3	4	5	6	7	8
Microphone	NG	NG	OK	OK	NG	NG	OK	OK
Audio Line	NG	NG	NG	NG	NG	NG	NG	NG
Microphone Key	-	-	-	-	-	-	-	-
Low Power Supply Voltage	-	-	-	-	-	-	-	-
RM Communication Error	-	-	-	-	-	-	-	-

**VX**

Item	Monitor Check
VX Internal Bus 1	NG
VX Internal Bus 2	NG
VX Internal Bus 3	NG
VX Internal Bus 4	NG
EV1 Failure	-
EV1 1kHz	-
EV2 Failure	-
EV2 1kHz	-

**SF**

Item	1	2	3	4	5
VX-SF Bus 1	NG	NG	NG	NG	NG
VX-SF Bus 2	NG	NG	NG	NG	NG
VX-SF Bus 3	NG	NG	NG	NG	NG
VX-SF Bus 4	NG	NG	NG	NG	NG
SF Bus Audio Switch 1	NG	NG	NG	NG	NG
SF Bus Audio Switch 2	NG	NG	NG	NG	NG
SF Bus Audio Switch 3	NG	NG	NG	NG	NG
SF Bus Audio Switch 4	NG	NG	NG	NG	NG
SF Bus Audio Switch 5	NG	NG	NG	NG	NG
SF Bus Audio Switch 6	NG	NG	NG	NG	NG
SF Bus Audio Switch 7	NG	NG	NG	NG	NG
SF Bus Audio Switch 8	-	-	-	-	NG
SF Bus Audio Switch 9	-	-	-	-	-
SF Bus Audio Switch 10	-	-	-	-	-
SF Communication Error	-	-	-	-	-

Legend:

- Automatic Inspection
- Automatic Inspection (Not Set)
- Manual Inspection
- Manual Inspection (Not Set)

Now checking monitor operation

Inspection Mode:  Automatic  Manual

Start Stop

**Step 3.** After check completion, press the [Stop] button to terminate automatic monitor check.

The dialog box "Monitor operation check was completed." will be displayed. Press the [OK] button to close the dialog box.

*Continued on next page*

**Step 4.** Switch the Inspection Mode to manual operation, then press the [Start] button to begin manual inspection.

During manual inspection, cables are removed or other failures are intentionally caused by hand in order to have such failures detected. When a failure is detected, the "NG indication" is displayed. In this manual inspection mode, failures are not automatically caused in the equipment.

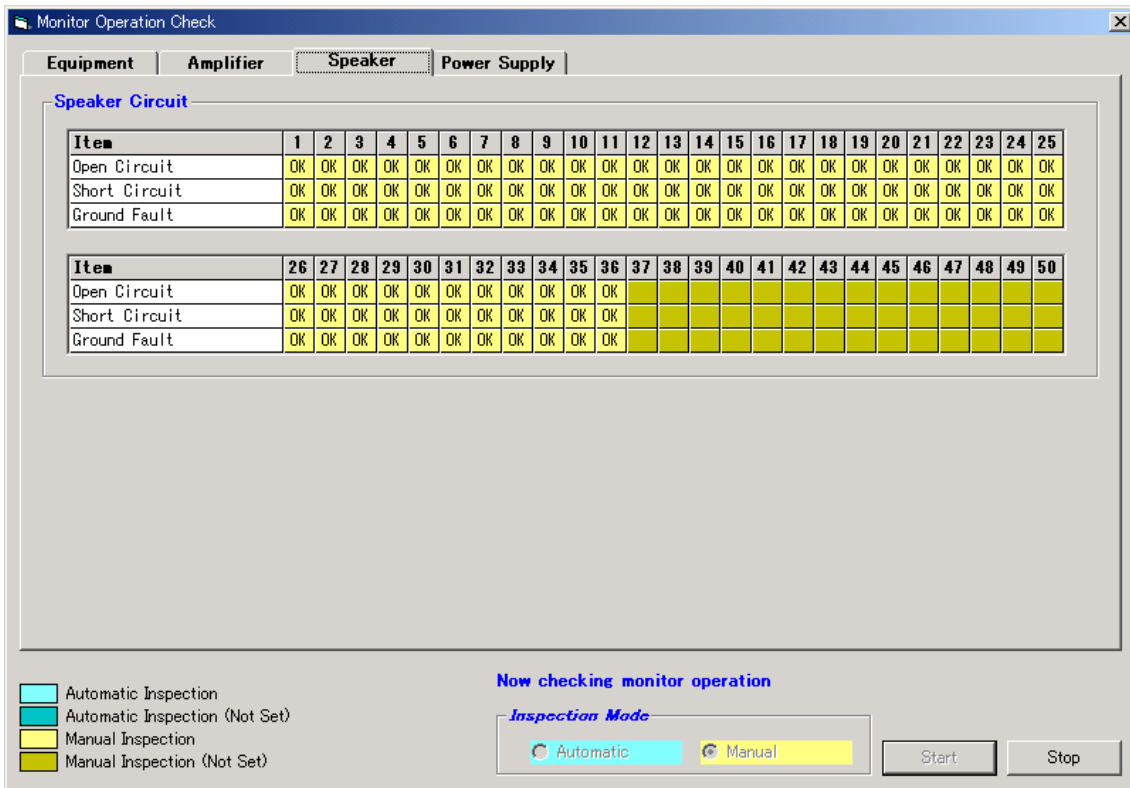

**Step 5.** After check completion, press the [Stop] button to terminate manual inspection.

The dialog box "Monitor operation check was completed." will be displayed. Press the [OK] button to close the dialog box.

**Step 6.** Click on the [OK] button in the [Monitor operation check] window to exit.

## 2. SYSTEM SETTING FILE UPLOAD

### Notes

- This function applies to the VX-2000 Setting Software Version 2.0 or later.
- System setting file upload cannot be performed in emergency mode.

The VX-2000's system setting file in use can be uploaded and displayed on the connected PC.

**Step 1.** Select [Communications → Upload (PC ← VX)] from the menu.

The following message will be displayed:

"The file under setup is closed and a new file will be opened. Is communication started?"

**Step 2.** Click on the [OK] button.

The [New Data Reception File] window will open.

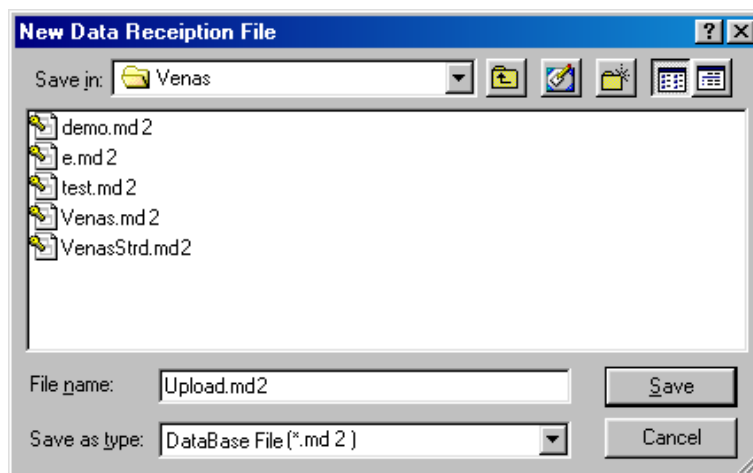

**Step 3.** Select the location to save the file and its filename, then click on the [Save] button.

### Note

Using the same filename as original one is invalid to protect the original data file from being overwritten.

The [System Information] window will then open.

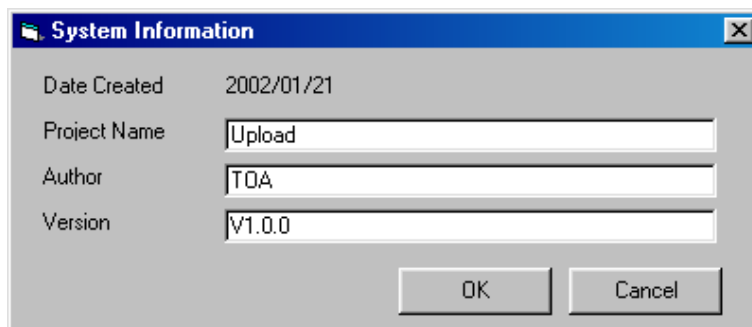

### [Difference of file extension depending on the software version]

The setting file extension is "md2" for the VX-2000 Setting Software Version 2.1 or later.

The file extension "mdb" is used for the file created by the Version 2.0, but it is converted to "md2" when saved to a PC.

So use the file with this extension "md2" thereafter.

*Continued on next page*

**Step 4.** Enter a project name, the name of Author, and Version, then click on the [OK] button.

Communications with the VX-2000 will be started, and the screen showing the communication status displayed.

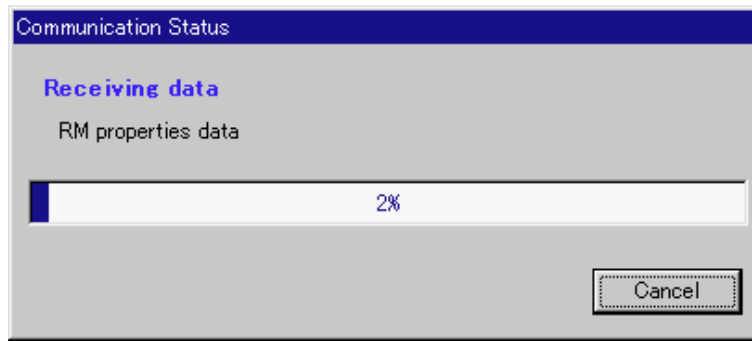

When data transfer is completed, the dialog box "Upload was completed normally." will be displayed. Pressing the [OK] button closes the dialog box, completing the upload.

#### Notes

- Uploaded files do not contain any user-set names (such as zone and pattern names). When the uploaded file is opened, a default name is displayed instead.
- The version in the System Information window is not the PC setting software version. Enter the version here to manage your system setting file.

### 3. READING LOGS

Operation logs stored inside the VX-2000 can be uploaded to a PC to display.

Up to 2,000 operation log events can be recorded. Events are deleted in chronological order when 2,000 is exceeded.

**Step 1.** Select [System → Log] from the menu.

The [View Log] window will open.

The screenshot shows the 'View Log' window for a device named 'VX-2000'. It features a 'View Condition' section with radio buttons for 'List All' (selected) and 'Select View', and checkboxes for 'Event', 'Monitor', 'Error', 'General', and 'Emergency'. An 'Update View' button is present. A 'No. of Data' field shows '0'. Below is a table with the following structure:

No.	Date	Time	Mode	Type	Detailed Code	Additional Information	Name
*							

At the bottom, there are buttons for 'Receive', 'Save', 'Print', and 'OK'.

*Continued on next page*



**Step 2.** Upload the logs.

Clicking on the [Receive] button permits communications to be started and the most recent log to be uploaded to the PC. Log events are displayed in chronological order.

The screenshot shows the 'View Log' window for VX-2000. The window title is 'View Log'. Below the title bar, the 'VX Name' is 'VX-2000'. The 'View Condition' section has two radio buttons: 'List All' (selected) and 'Select View'. To the right of 'Select View' are three checkboxes: 'Event', 'Monitor', and 'Error'. Further right are two checkboxes: 'General' and 'Emergency'. An 'Update View' button is located to the right of these checkboxes. The 'No. of Data' is displayed as '1049'.

No.	Date	Time	Mode	Type	Detailed Code	Additional Information	Name
1	2002/04/15	21:23:05	Normal	Event	Timer Event	Base Pattern Change 1 Make	
2	2002/04/15	21:23:05	Normal	Event	Timer Event	Base Pattern Change 2 Make	
3	2002/04/15	21:23:05	Normal	Event	Timer Event	Base Pattern Change 3 Make	
4	2002/04/15	21:24:12	Normal	Event	RM/FM Event	RM2 Failure Output Reset 0 Make	RM-2
5	2002/04/15	21:24:13	Normal	Event	RM/FM Event	RM2 Failure Output Reset 0 Make	RM-2
6	2002/04/15	21:24:14	Normal	Event	RM/FM Event	RM2 Failure Output Reset 0 Make	RM-2
7	2002/04/15	21:24:25	Normal	Event	Control Input Event	CIN33 None 0 Make	Cin-33
8	2002/04/15	21:24:25	Normal	Event	Control Input Event	CIN34 None 0 Make	Cin-34
9	2002/04/15	21:24:25	Normal	Event	Control Input Event	CIN35 None 0 Make	Cin-35
10	2002/04/15	21:24:25	Normal	Event	Control Input Event	CIN36 None 0 Make	Cin-36
11	2002/04/15	21:24:25	Normal	Event	Control Input Event	CIN37 None 0 Make	Cin-37
12	2002/04/15	21:24:25	Normal	Event	Control Input Event	CIN38 None 0 Make	Cin-38
13	2002/04/15	21:24:25	Normal	Event	Control Input Event	CIN39 None 0 Make	Cin-39
14	2002/04/15	21:24:25	Normal	Event	Control Input Event	CIN40 None 0 Make	Cin-40
15	2002/04/15	21:24:25	Normal	Event	Control Input Event	CIN41 None 0 Make	Cin-41
16	2002/04/15	21:24:25	Normal	Event	Control Input Event	CIN42 None 0 Make	Cin-42
17	2002/04/15	21:24:25	Normal	Event	Control Input Event	CIN43 None 0 Make	Cin-43
18	2002/04/15	21:24:25	Normal	Event	Control Input Event	CIN44 None 0 Make	Cin-44
19	2002/04/15	21:24:25	Normal	Event	Control Input Event	CIN45 None 0 Make	Cin-45
20	2002/04/15	21:24:25	Normal	Event	Control Input Event	CIN46 None 0 Make	Cin-46

At the bottom of the window, there are four buttons: 'Receive' (circled in red), 'Save', 'Print', and 'OK'.

*Continued on next page*

**Step 3.** Set the log to be viewed in the [View Condition] area.

The type of log to be displayed can be selected.

- List All: All stored logs can be viewed.
- Select View: Only the desired logs are selected and displayed.  
Tick the "Event," "Monitor," or "Error" checkbox for the data to be viewed.  
More than one checkbox can be ticked. If "Event" is selected, further select either "General" or "Emergency."

**Step 4.** Click the [Update View] button.

Logs set under the view condition in Step 3 will be selected and displayed.

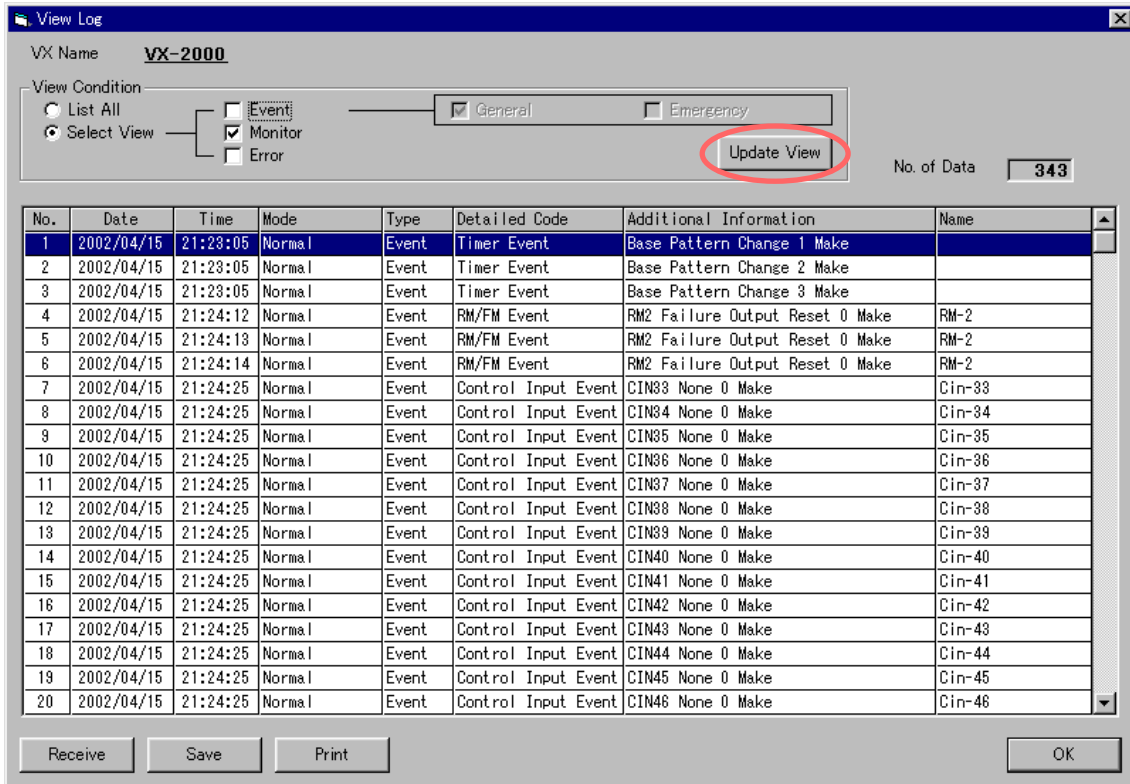
**Step 5.** Logs displayed in the [View Log] window can be stored as csv formatted text files.

Click on the [Save] button, and the [Log Filename Settings] window will open.

Select the location to save the file and its filename, then click on the [Save] button again.

**Step 6.** Logs displayed on the [View Log] window can be printed out.

Click on the [Print] button to print.

**Step 7.** Click on the [OK] button to close the [View Log] window.**Tip**

Logs are maintained for 7 days in case of power outage to the VX-2000.

## 4. VERSION DISPLAY

Selecting [Help → Version] from the menu enables confirmation of the version number of the "VX-2000 Setting Software and the VX-2000 firmware."

# ***Chapter 12***

---

## ***APPENDIX***

## 1. CF CARD RECORDING METHODS

Messages can be recorded on the CF card in either way of using the EV-350R Digital Announcer or using the PC software program dedicated for the EV-200.

### 1.1. Recording by the EV-350R

Create the program referring to the descriptions given here.

#### 1.1.1. Program

The word "program" used for the EV-350R represents playback data consisting of both playback sound data (sentences and silent intervals) and control data (volume levels and playback methods). In the VX-2000 system, the playback data is referred to as the "EV message."

#### [Contents to be entered into the program]

Data	Content
Playback sound data	Combination of sentence and silent interval (maximum 128 steps)
Control data	Playback method* <sup>1</sup> (one of the four methods)
	Output (from output 1 or output 2 or simultaneously from both)* <sup>2</sup>
	Program name (program title)* <sup>2</sup>
	Program sound volume

\*<sup>1</sup> The following 4 Playback methods are available: Continuous Program, Single Program, Repeat, and Endless. As for the VX-2000 system, however, select the Continuous Program Playback.

\*<sup>2</sup> Not related to VX-2000 playback operation.

### 1.1.2. CF Card Recording Contents

Up to 128 sentences (up to 512 sentences depending on the EV-350R setting) and 8 programs can be recorded on the CF card. Programs P001 – P008 correspond to EV messages 1 – 8. When EV Message 1 is played back in the VX-2000, playback data set in P001 is recalled.

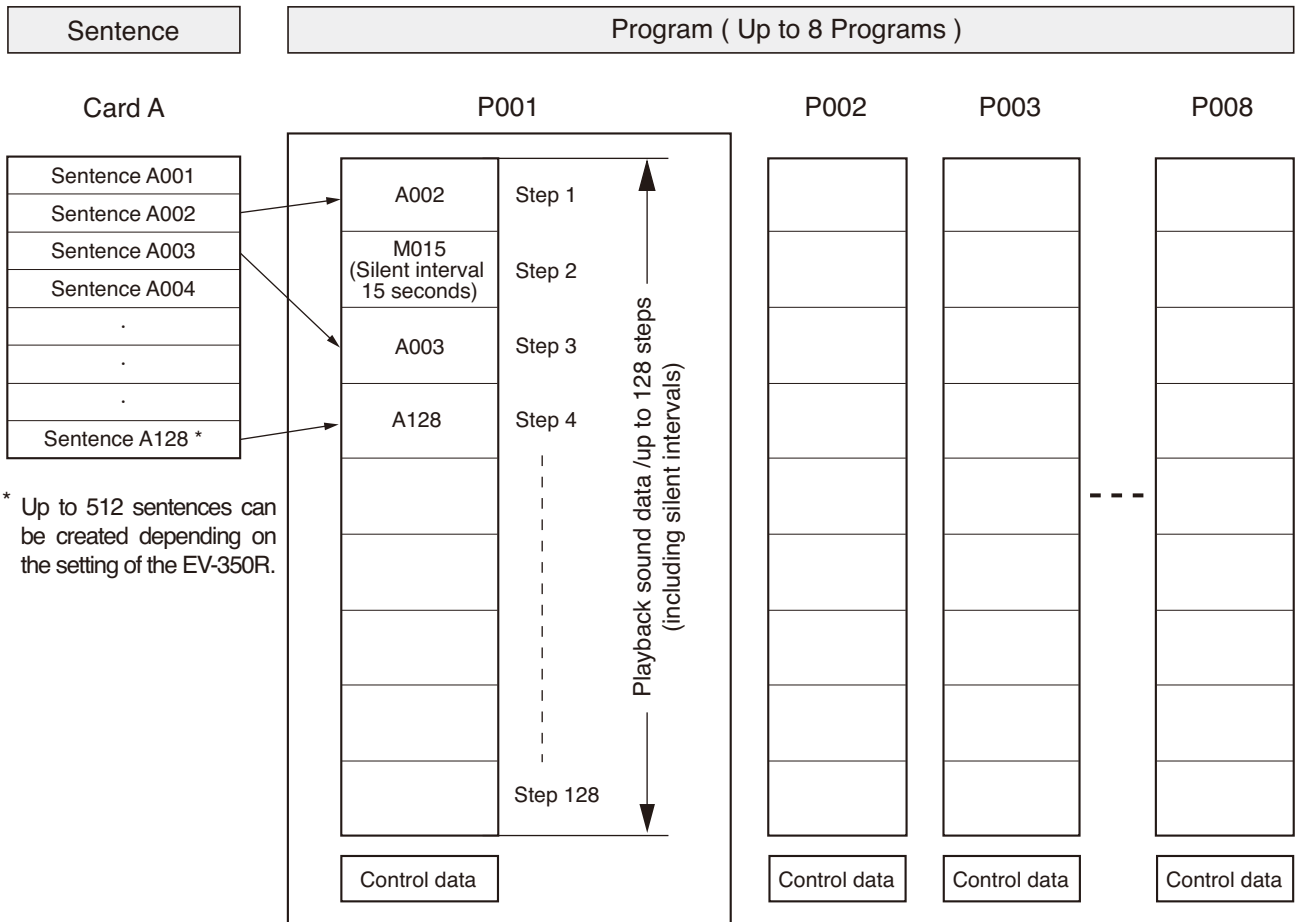

#### Notes

- In the VX-2000 system, only up to 8 EV messages can be broadcast per EV-200 unit although more than 8 messages can be recorded and broadcast when the EV-350R is used.
- To perform single program playback or repeat playback, the busy output for program or repeat interval needs to be set. When wishing to output a busy signal between messages, set the busy output to ON. The output is factory-preset to ON.

### 1.1.3. Setting Example

#### [Message Program/Sentence Composition Example]

VX unit's Message No.	Program No.	Playback method	Sentence No. or Silent Section	EV message type
Message 1	P001	Continuous Program Playback	A001, A002, M003, A003	Alert
Message 2	P002		A011, A012, M002, A013	Evacuation
Message 3	P003		A021, A022, M002, A023	Reset
Message 4	P004		A031	General (General-purpose broadcast)
Message 5	P005		A041	
Message 6	P006		A051, M001, A052, M002	
Message 7	P007		A061, M001, A062, M002	
Message 8	P008		A071	

#### Note

EV messages are divided into 4 types in the VX-2000 system: Alert, Evacuation, Reset, and General. The message type must be set for each EV message number using the PC software. When recording, message types set with the PC software must correspond to the message contents. For details of the setting, refer to p. 7-28.

#### [Message Program Example]

The programs shown in the above example operate as follows.

Alert message (Program No. 1)

[Continuous program playback method]

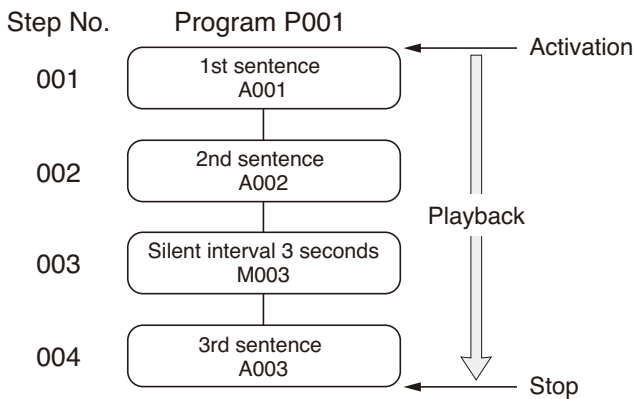

#### 1.1.4. Usable CF cards (their card adapter required)

- Use the "SanDisk"\* CompactFlash\* (CF) card.  
\* Trademark of SanDisk Corporation
- Required card capacity (under 96 MB) depends on the recording time and sound quality.

#### [CF Card Capacity vs. Recording Time]

Capacity (MB)	Recording Sound Quality*			
	Low	Normal	High	Extremely High
16	0:33:09	0:22:06	0:16:34	0:11:03
32	1:06:36	0:44:24	0:33:18	0:22:12
48	2:13:30	1:29:00	1:06:45	0:44:30
96	3:20:08	2:13:25	1:40:04	1:06:42

\* The shorter the recording time is, the higher the sound quality is.

- Be sure to keep 10-second or longer unrecorded portion on the card because it is used for controlling the EV-200 board's surveillance function.
- When the CF card is first inserted into the EV-200, a pilot tone is written in the card.
- A dedicated adapter is required for CF card recording. Place the CF card in the CompactFlash card adapter, then insert the adapter into the memory card slot on the EV-350R's front panel.

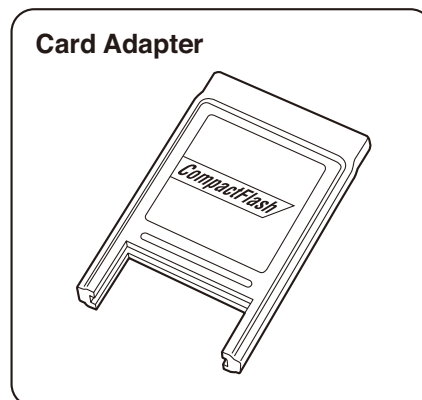
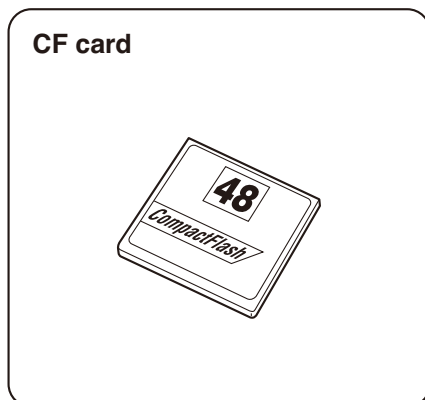

- Details of recording are described in the EV-350R's Instruction Manual.

#### Cautions

- When mounting the EV-200 on the VX-2000, be sure to remove the CF card from the EV-200 because the EV-200 or the CF card may fail.
- Avoid inserting or withdrawing the CF card while the VX-2000 is alive.



## 1.2. Recording by the EV-200 Data Edit Software

Download the EV-200.msi EV-200 Data Edit Software and its instruction manual from <http://toa-products.com/international/>.

Refer to the downloaded instruction manual for details about the recording method.

### Note

The EV-200 Data Edit Software is freeware. Please note that no supports such as bug fixing and updating are provided.

### Points to be noted

When the EV-200 firmware version\* is Ver.1.00 or Ver.2.00, the CF card recorded using the EV-200 Data Edit Software cannot be played back.

In this case, the EV-200 firmware can be updated to Ver.3.00 or later, permitting the use of this software for the playback.

To update, download the firmware file and the update instruction manual from <http://toa-products.com/international/>. Refer to the downloaded manual for details about the updating procedure.

\* Confirming the EV-200 firmware version

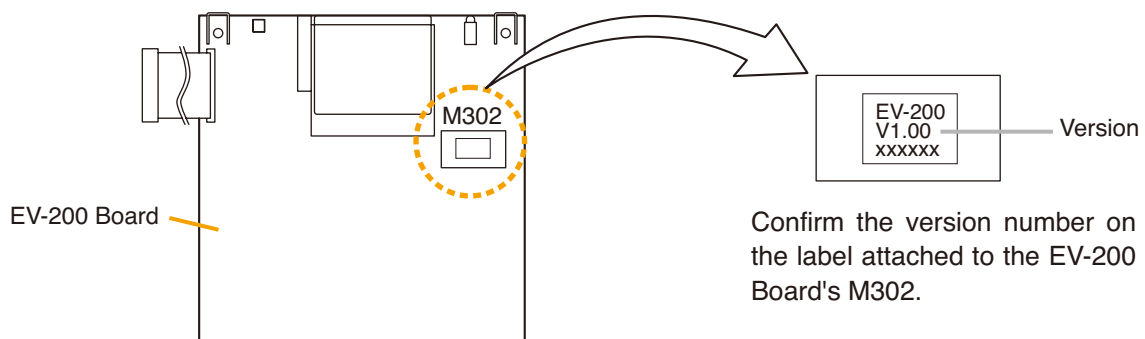

# ***Chapter 13***

---

## ***SPECIFICATIONS***

# 1. BLOCK DIAGRAM

## 1.1. Fireman's Microphone RM-200XF

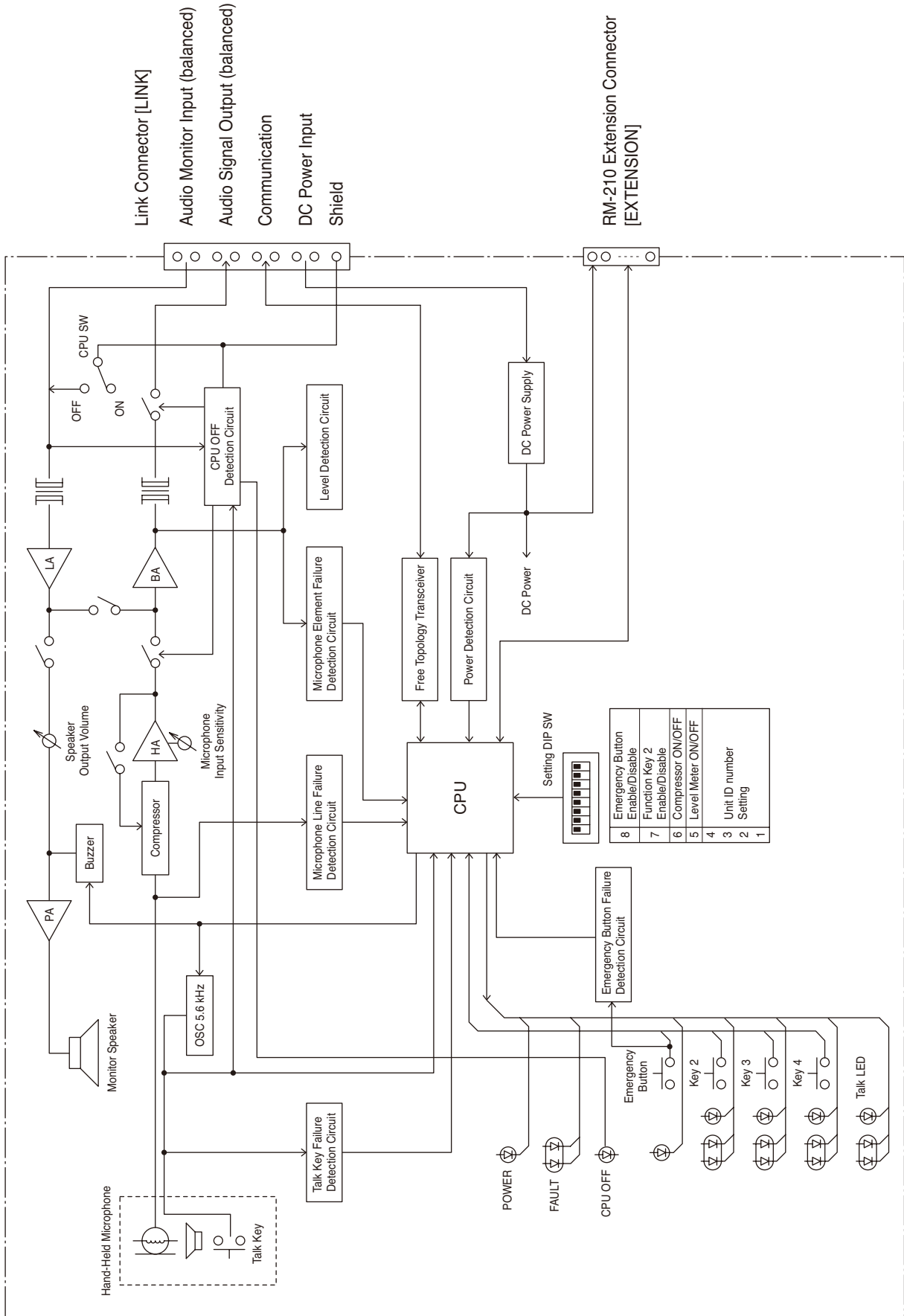

### 1.2. Remote Microphone RM-200X

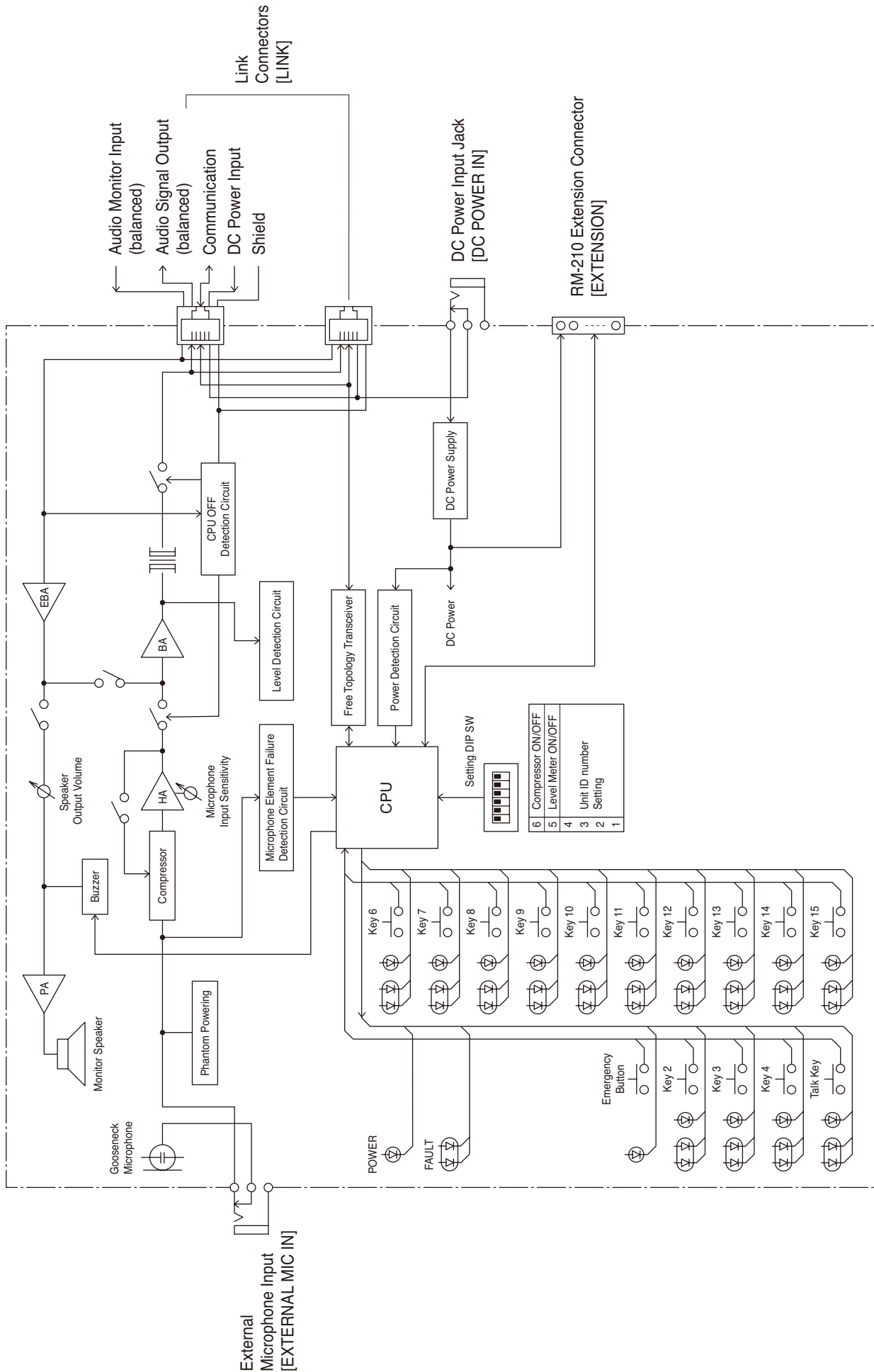

### 1.3. Remote Microphone Input Module VX-200XR

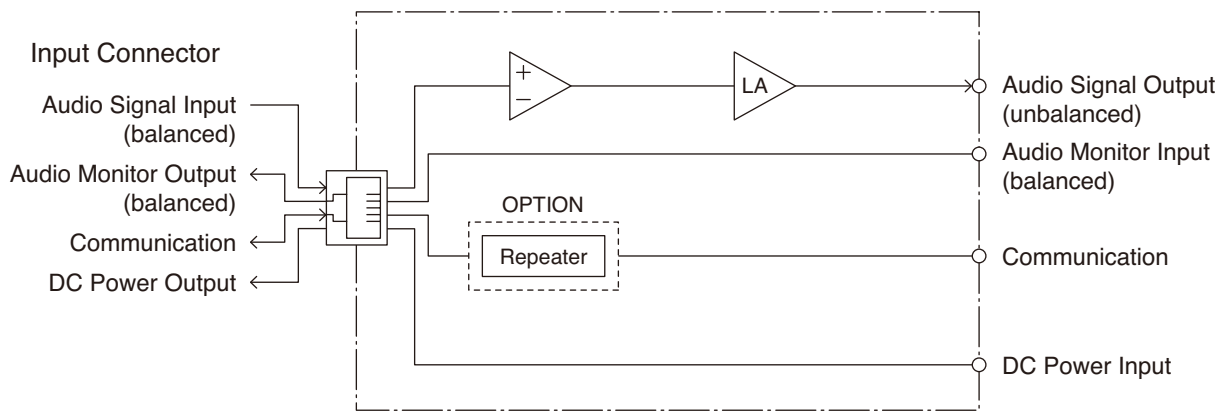

### 1.4. Audio Input Module with Control Input VX-200XI

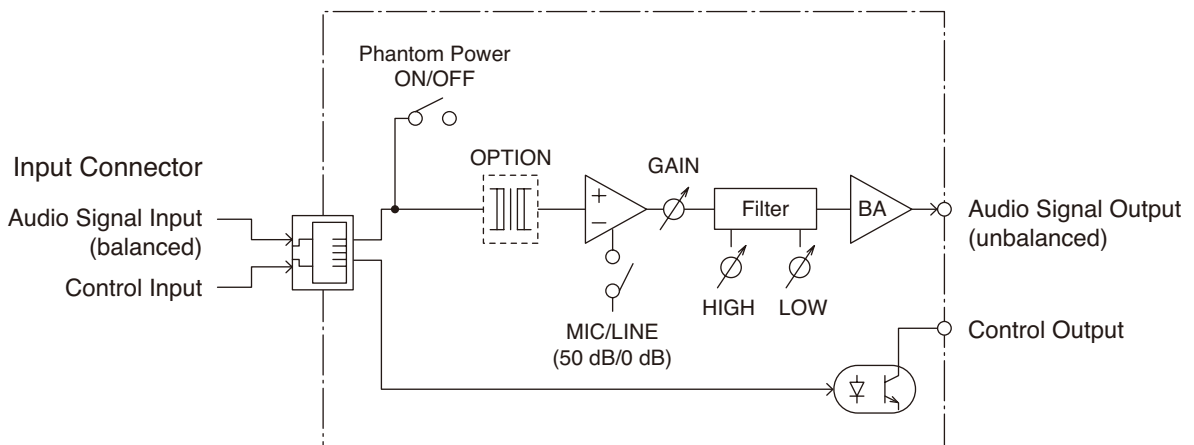

### 1.5. System Manager VX-2000

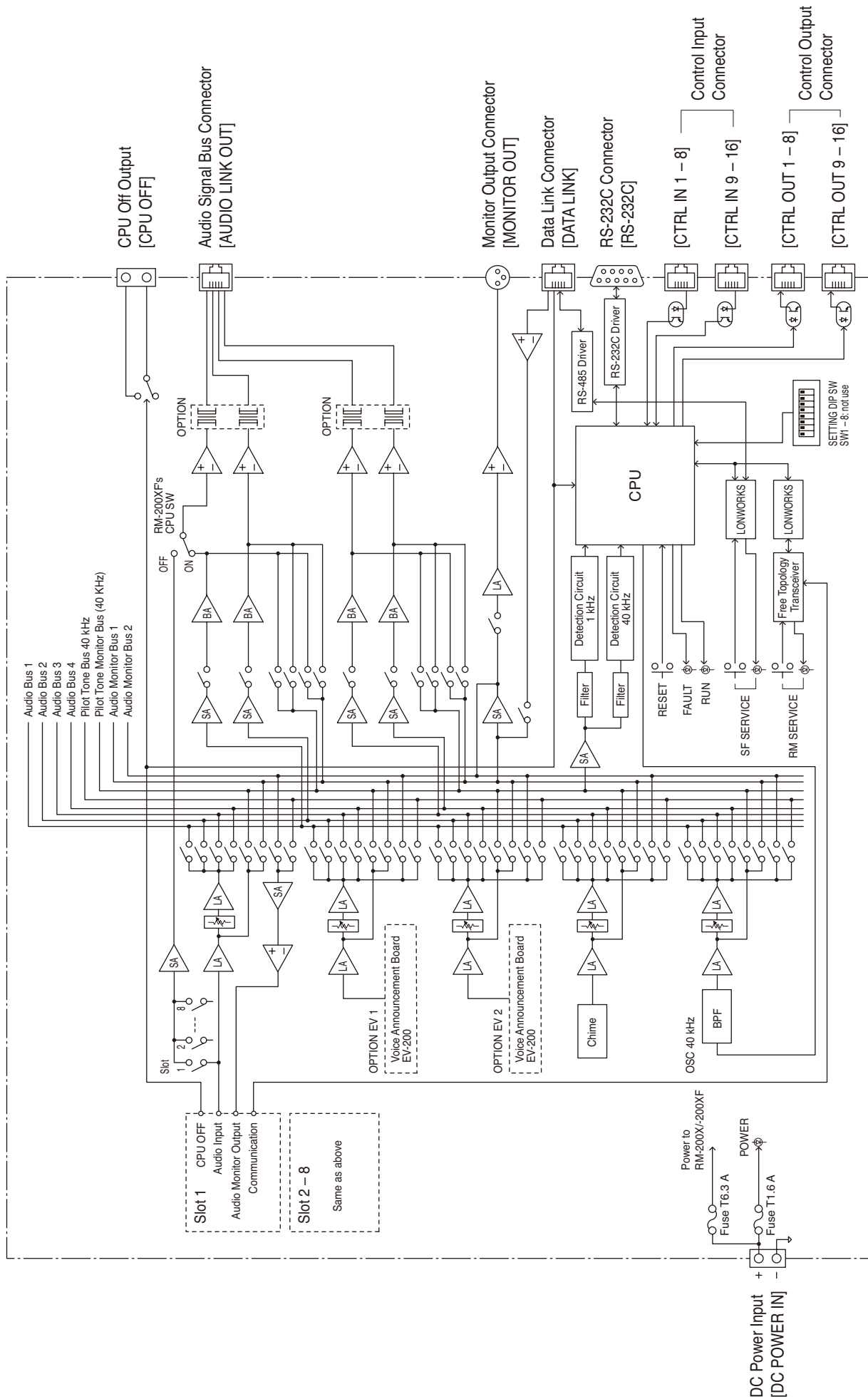

### 1.6. Surveillance Frame VX-2000SF

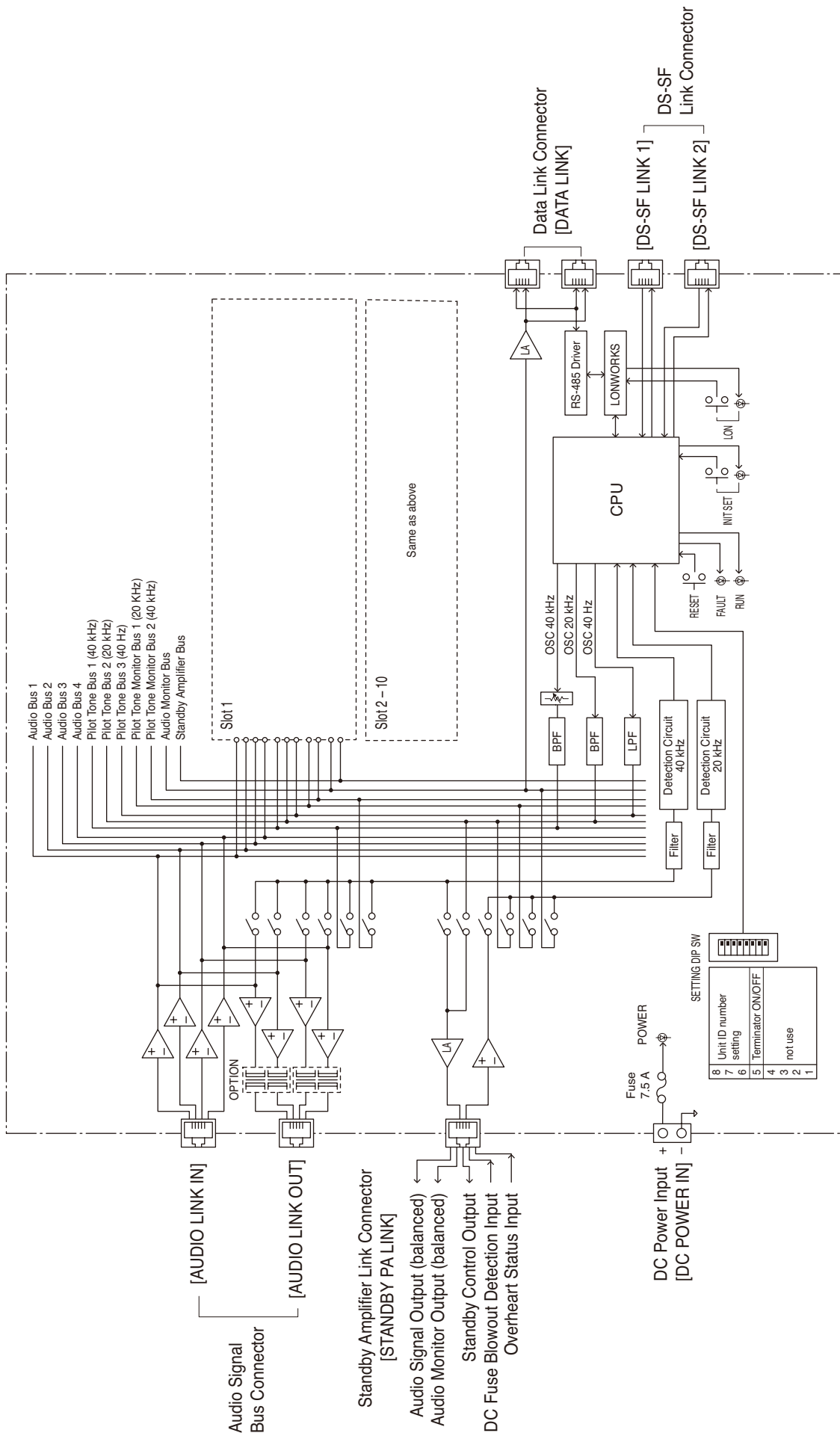

### 1.7. Pilot Tone Detection Module VX-200SP

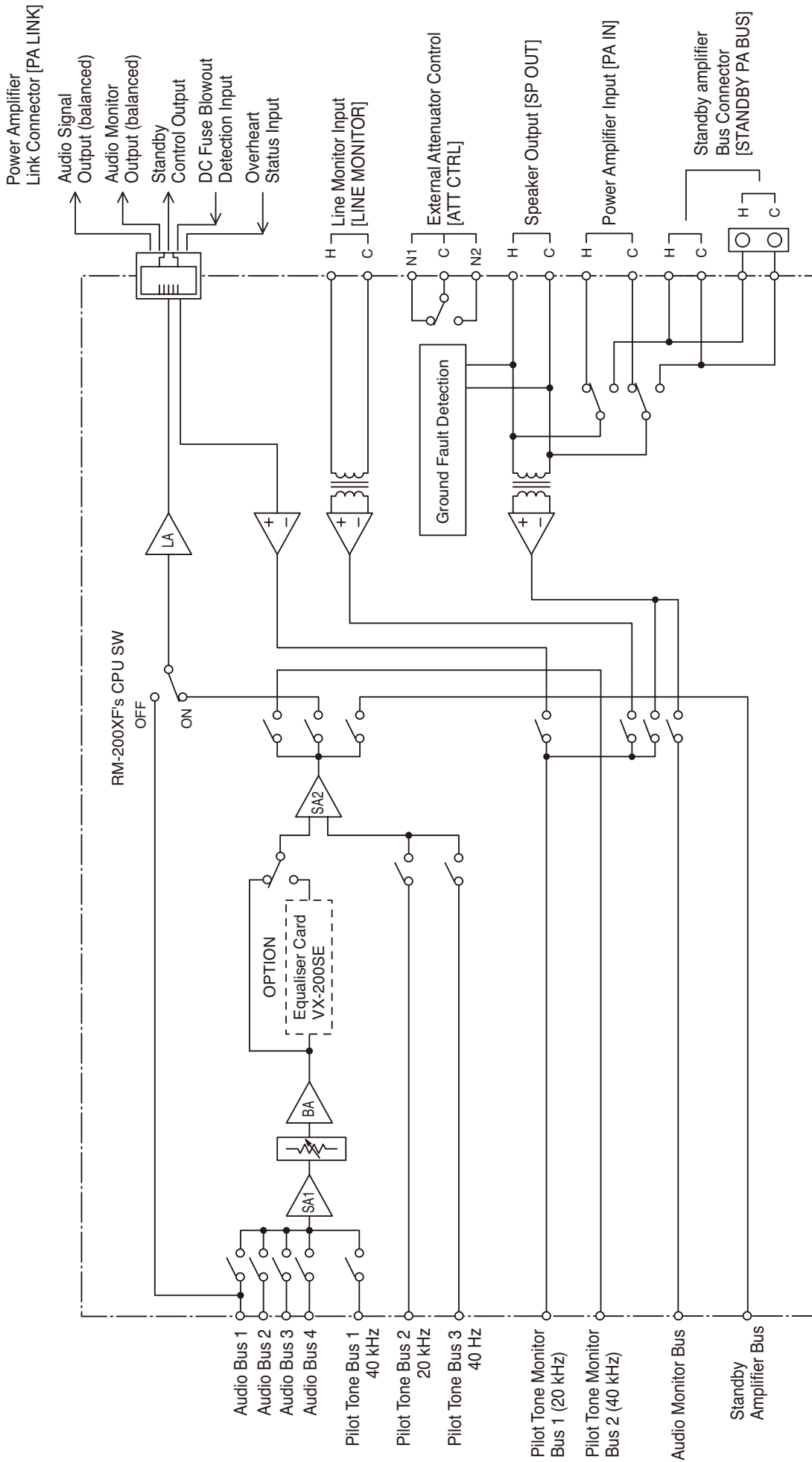



### 1.8. Impedance Detection Module VX-200SZ

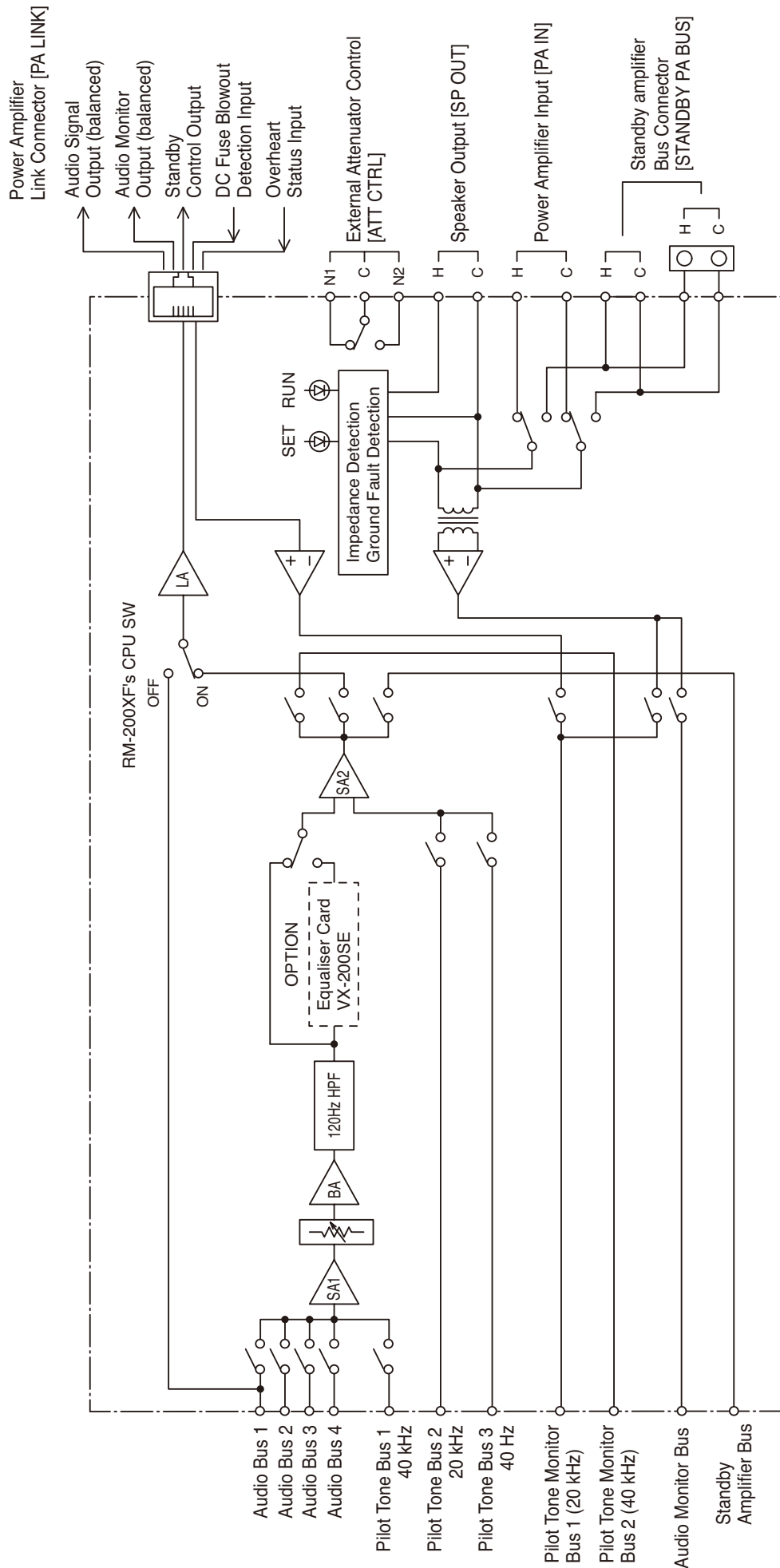

### 1.9. Power Amplifier Input Module VP-200VX

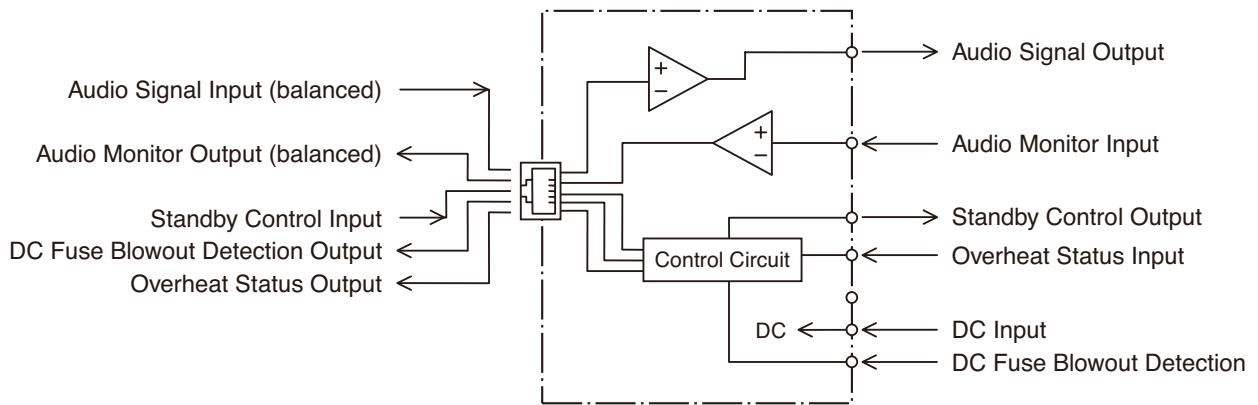

### 1.10. Power Amplifier 1 x 240 W VP-2241 and Power Amplifier 1 x 420 W VP-2421

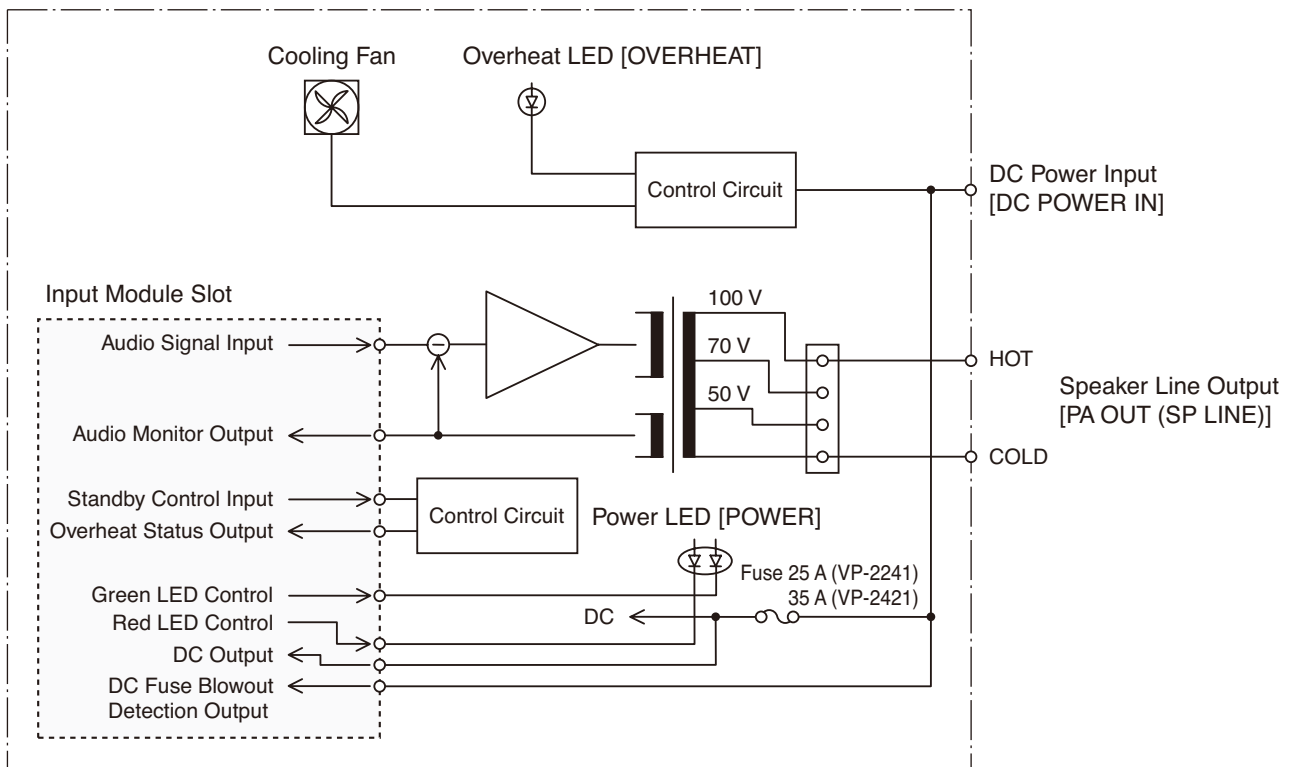

### 1.11. Power Amplifier 2 x 120 W VP-2122

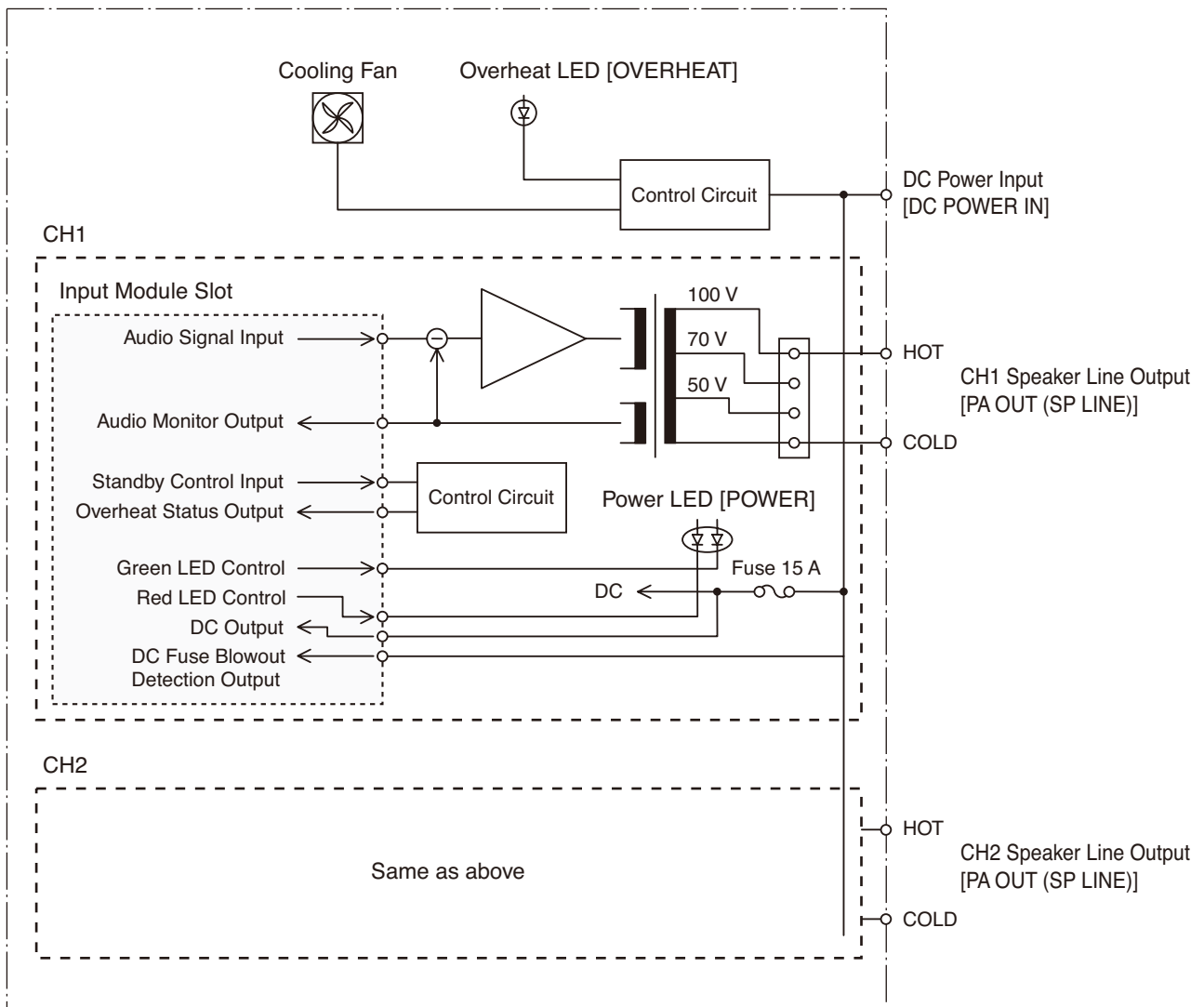

### 1.12. Power Amplifier 4 x 60 W VP-2064

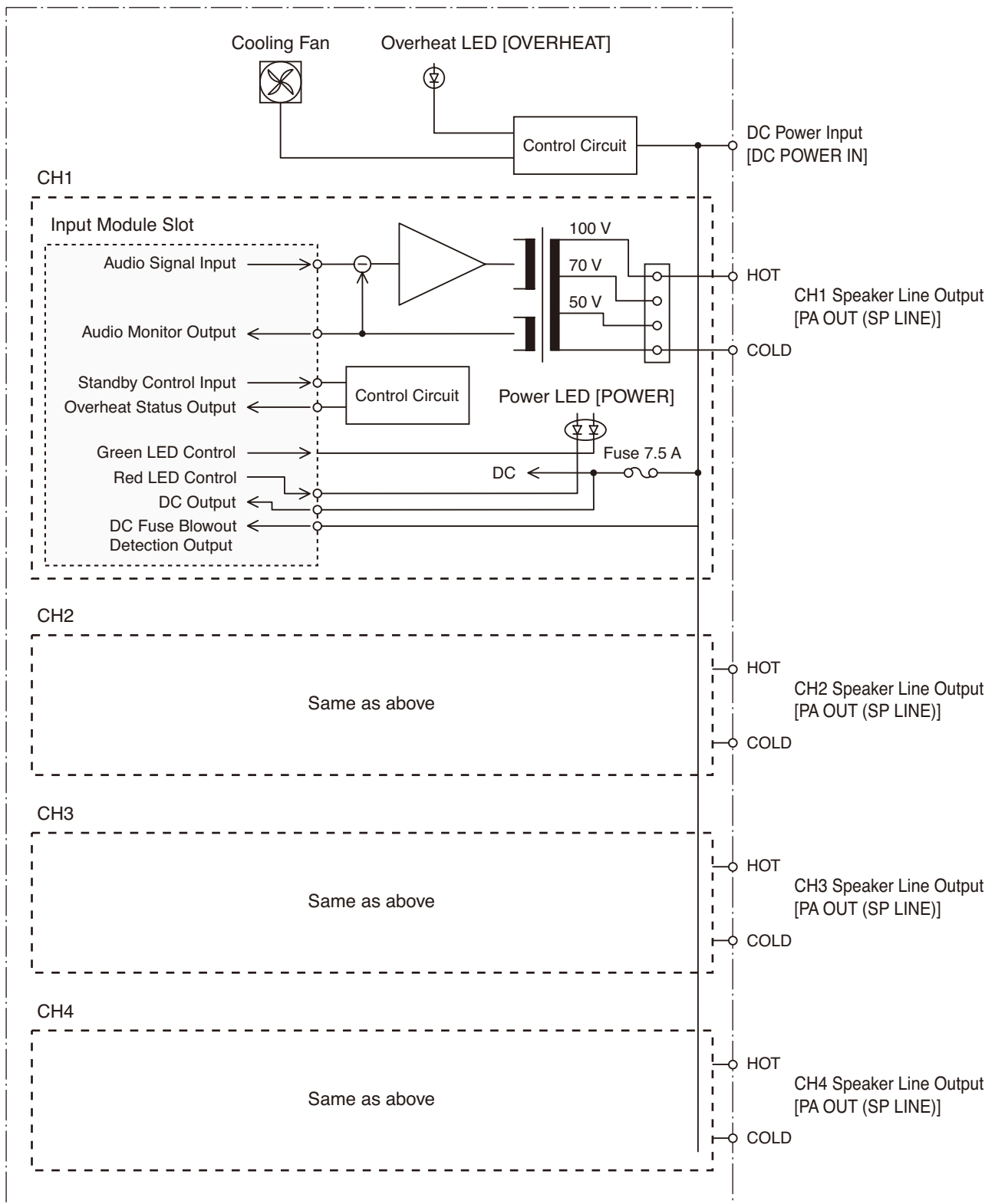

1.13. Power Amplifier 4 x 150 W VP-3154, Power Amplifier 4 x 300 W VP-3304, and Power Amplifier 4 x 500 W VP-3504

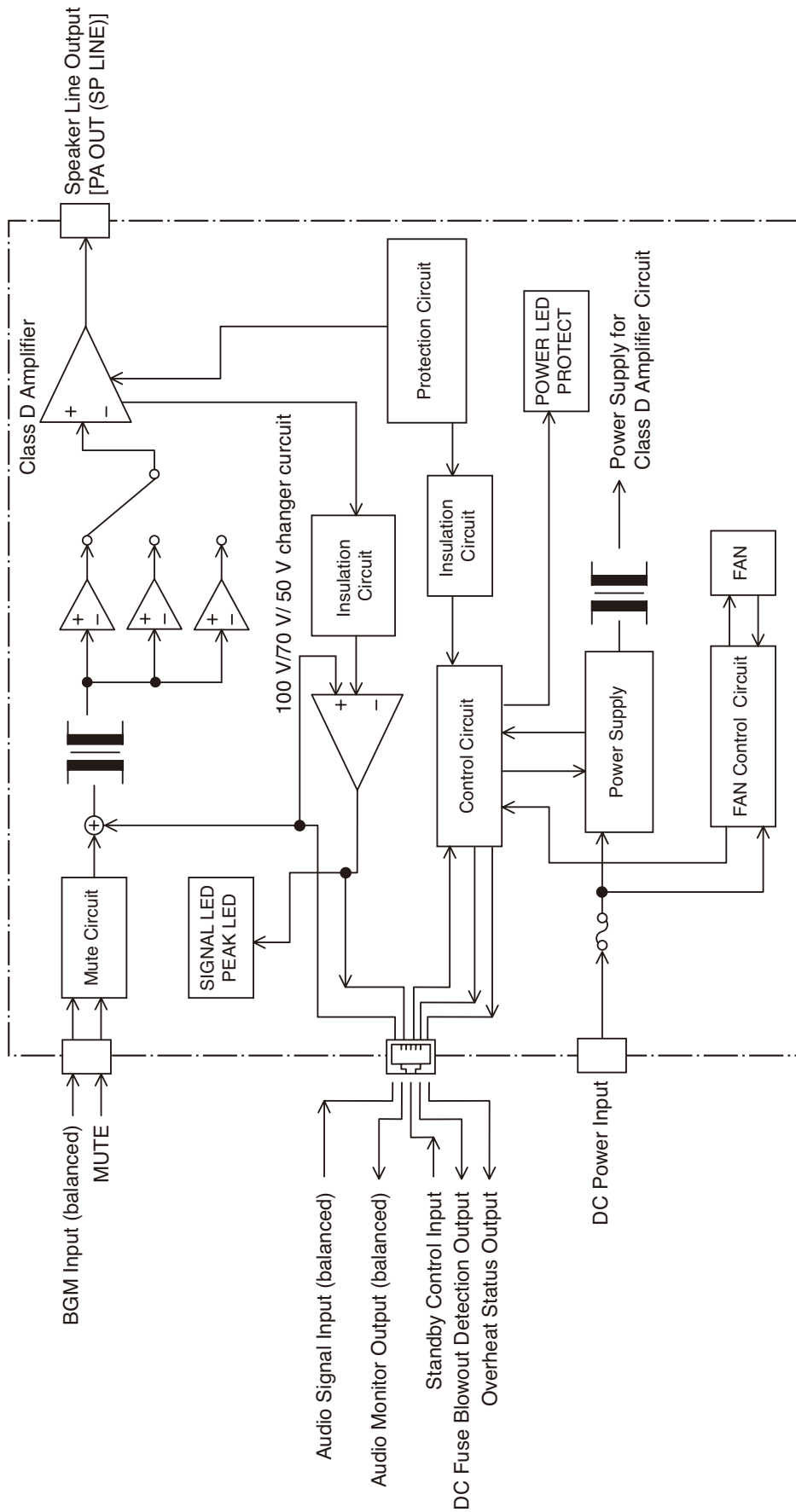

## 2. SPECIFICATIONS

### 2.1. Fireman's Microphone RM-200XF

Power Source	24 V DC (operating range: 16 – 40 V DC)
Current Consumption	Under 200 mA (RM-200XF), 850 mA (with 10 RM-210s connected)
Audio Output	0 dB*, 600 Ω, balanced
Hand-Held Microphone	Dynamic microphone, Function switch (default: Press-to-talk), Microphone element fault detection
Distortion	Under 1%
Frequency Response	200 Hz – 15 kHz
Signal to Noise Ratio	Over 55 dB
Internal Monitor Speaker	200 mW
Volume Control	Microphone volume control, Monitor speaker volume control
Number of Function Keys	5 (including Hand-held microphone's switch), extendable up to 105 (with 10 RM-210s connected)
Key Extension	10 keys extension per RM-210, EXTENSION connector
Number of Connectable Units	4
Communication System	LONWORKS Twisted Pair Free Topology Transceiver
Connection Cable and Connector	Category 5 STP cable, plug-in screw connector
Communication Distance	500 m (free topology wiring)
Finish	ABS resin, blueish gray (PANTONE 538 or its equivalent)
Dimensions	200 (w) x 215 (h) x 82.5 (d) mm (excluding the coiled cord)
Weight	1.2 kg
Applicable Box	YC-301, YS-11A

\* 0 dB = 1 V

**Note:** The design and specifications are subject to change without notice for improvement.

#### • Accessories

Plug-in screw terminal .....	1
Wall mounting bracket .....	1
Wall mounting screw .....	2
Box mounting screw .....	2

## 2.2. Remote Microphone RM-200X

Power Source	24 V DC (operating range: 16 – 40 V DC), supplied from RJ45 connector or power input jack (non-polarity type) Usable power input plug: 5.5 mm outer diameter, 2.1 mm inner diameter, and 9.5 mm long
Current Consumption	Under 200 mA (RM-200X), 750 mA (with 9 RM-210s connected)
Audio Output	0 dB*, 600 Ω, balanced, RJ45 connector
Gooseneck Microphone	Unidirectional electret condenser microphone
External Microphone Input	–40 dB*, 2.2 kΩ, unbalanced, mini jack, phantom powering
Distortion	Under 1%
Frequency Response	100 Hz – 20 kHz
Signal to Noise Ratio	Over 60 dB
Internal Monitor Speaker	200 mW
Volume Control	Microphone volume control, Monitor speaker volume control
Number of Function Keys	15, extendable up to 105 (with 9 RM-210s connected)
Key Extension	10 keys extension per RM-210, EXTENSION connector
Number of Connectable Units	8 (include RM-200XF)
Communication System	LONWORKS Twisted Pair Free Topology Transceiver
Connection Cable and Connector	Category 5 STP cable, RJ45 connector
Communication Distance	500 m (free topology wiring)
Finish	ABS resin, blueish gray (PANTONE 538 or its equivalent)
Dimensions	190 (w) x 76.5 (h) x 215 (d) mm (gooseneck microphone excluded)
Weight	850 g

\* 0 dB = 1 V

**Note:** The design and specifications are subject to change without notice for improvement.

### 2.3. Remote Microphone Extension RM-210

Current Consumption	20 mA max. (in terms of RM-200M's DC power input) 75 mA max. (in terms of DC power inputs of RM-200X and RM-200XF)
Connection	Connection to RM-200M, RM-200X or RM-200XF by way of dedicated cable
Number of Function Keys	10
Function	When used to expand the RM-200M: Selects and activates the Voice Announcement Board messages. When used to expand the RM-200X and RM-200XF (PC software setting): Emergency activation, Emergency reset, BGM pattern selection, EV message activation, Broadcast zone selection, Monitor zone selection, Chime activation, Talk key activation, Control output activation, Input volume adjustment, Zone volume adjustment, and Failure output indication and Reset.
Finish	ABS resin, blueish gray (PANTONE 538 or its equivalent)
Dimensions	110 (w) x 76.5 (h) x 215 (d) mm
Weight	350 g

**Note:** The design and specifications are subject to change without notice for improvement.

#### • Accessories

Extension cable .....	1
Linkage bracket A .....	2
Linkage bracket B .....	1
Screw for linkage bracket .....	12



## 2.4. System Manager VX-2000

Power Source	24 V DC (operating range: 20 – 40 V DC) M3.5 screw terminal, distance between barriers: 8.8 mm
Current Consumption	Under 650 mA (20 V DC)
Input	–20 dB*, unbalanced, Number of module slots: 8
Usable Input Module	VX-200XR, VX-200XI, 900 series plug-in modules (M-01F, M-01M, M-01P, M-01S, M-01T, M-03P, M-51F, M-51S, M-51T, M-61F, M-61S, M-61T, U-01F, U-01P, U-01R, U-01S, U-01T, U-03R, U-03S, U-61S, U-61T)
Audio Link Output	Number of audio buses: 4 0 dB*, electronically balanced, RJ45 female connector Twisted-pair straight cable (TIA/EIA-568A standard)
Monitor Output	0 dB*, electronically balanced, XLR receptacle (3 pins)
Frequency Response	20 Hz – 20 kHz
Signal to Noise Ratio	Over 60 dB
Distortion	Under 0.5%
Cross Talk	Under –60 dB (1 kHz, 0 dB*)
Control Input	16 inputs, no-voltage make contact, open voltage: 17 V DC, short circuit current: Under 5 mA, RJ45 connector x 2
Control Output	16 outputs, open collector output, withstand voltage: 30 V DC, control current: Under 5 mA, RJ45 connector x 2
Chime Tone	Built-in chime: 4-tone chime (up) / 4-tone chime (down) / 2-tone chime / Gong
Communication System	PC (Setting software to be installed): D-sub connector (9 pins), cross cable, RS-232C VX-2000SF: RJ45 female connector, Twisted-pair straight cable (TIA/EIA-568A standard), LONWORKS RS-485
Operating Temperature	0 to +40°C
Finish	Panel: Surface-treated steel plate, black (30% glossy), paint
Dimensions	482 (w) x 132.6 (h) x 337 (d) mm
Weight	6.4 kg

\* 0 dB = 1 V

**Note:** The design and specifications are subject to change without notice for improvement.

### • Accessories

Rack mount bracket (preinstalled on the unit) .....	2
Rack mounting screw (5 x 12) .....	4
Fiber washer .....	4
Blank panel .....	7
Blank panel mounting screw .....	14
Setting software installation CD .....	1
Fuse (T1.6 A L) .....	1
Fuse (T6.3 A L) .....	1

### • Optional products

Voice announcement board: EV-200

Isolation transformer: IT-450 (audio link output)

## 2.5. Voice Announcement Board EV-200M

Power Source	24 V DC, 0.2 A
Power Consumption	5 W
Output	0 dB*
Frequency Response	20 Hz – 20 kHz (44.1 kHz sampling) 20 Hz – 14 kHz (32 kHz sampling)
Distortion	Under 0.3% (44.1 kHz, recording method: Extremely High)
Playback Mode	Single source playback
No. of Playback Program	8 programs
Operating Temperature	0 to +50°C
Operating Humidity	Under 90% (no condensation)
Dimensions	120 (w) x 18.6 (h) x 121 (d) mm
Weight	120 g

\* 0 dB = 1 V

### Notes

- Use the CompactFlash card adapter on the market for recording by the EV-350R.
- The design and specifications are subject to change without notice for improvement.

### • Accessories

Mounting screw .....	2
CompactFlash card (128 MB, preinstalled on the unit) .....	1

## 2.6. Remote Microphone Input Module VX-200XR

Power Source	Supplied from VX-2000
Current Consumption	Under 17 mA
Connectable Remote Microphone	RM-200X and RM-200XF
Input Connector	RJ45 female connector Twisted-pair straight cable (TIA/EIA-568A standard)
Finish	Panel: Aluminum, hairline
Dimensions	35 (w) x 78 (h) x 88 (d) mm
Weight	70 g
Applicable Model	VX-2000

**Note:** The design and specifications are subject to change without notice for improvement.

### • Accessories

Mounting screw .....	2
----------------------	---

## 2.7. Audio Input Module with Control Input VX-200XI

Power Source	Supplied from VX-2000
Current Consumption	Under 30 mA
Input Sensitivity (Rated Output -20 dB)	MIC: -70 to -42.5 dB* (adjustable) LINE: -20 to +7.5 dB* (adjustable) MIC or LINE selectable by the built-in switch
Low Cut Filter (100 Hz)	9 to 15 dB attenuation (adjustable)
High Cut Filter (10 kHz)	8 to 14 dB attenuation (adjustable)
Distortion	Under 0.5%
Frequency Response	50 Hz – 20 kHz
Phantom Power	15 V (open), 6 V (current consumption 3.3 mA)
Control Input	No-voltage make contact, open voltage: 17 V DC, short circuit current: Under 5 mA
Input Connector	RJ45 female connector Twisted-pair straight cable (TIA/EIA-568A standard)
Finish	Panel: Aluminum, hairline
Dimensions	35 (w) x 78 (h) x 88 (d) mm
Weight	70 g
Applicable Model	VX-2000

\* 0 dB = 1 V

**Note:** The design and specifications are subject to change without notice for improvement.

### • Accessories

Mounting screw ..... 2

### • Optional product

Isolation transformer: IT-450

## 2.8. Surveillance Frame VX-2000SF

Power Source	24 V DC (operating range: 20 – 40 V DC) M3.5 screw terminal, distance between barriers: 8.8 mm
Current Consumption	Under 2 A (40 V DC)
Number of Module Slot	10
Usable Module	VX-200SZ, VX-200SP, VX-200SI, VX-200SO
Frequency Response	20 Hz – 20 kHz
Signal to Noise Ratio	Over 60 dB
Distortion	Under 0.5%
Cross Talk	Under –60 dB (1 kHz, 0 dB*)
Audio Link Input/Output	Number of audio busses: 4 0 dB*, electronically balanced, RJ45 female connector Twisted-pair straight cable (TIA/EIA-586A standard)
Standby Amplifier Link	RJ45 female connector for connecting the VP-2000 series or VP-3000 series Power Amplifier Twisted-pair straight cable (TIA/EIA-586A standard)
Communication System	VX-2000, VX-2000SF: RJ45 female connector x 2, LONWORKS RS-485 VX-2000DS, VX-3000DS: RJ45 female connector x 2, Twisted-pair straight cable (TIA/EIA-586A standard)
Operating Temperature	0 to +40°C
Finish	Panel: Surface-treated steel plate, black (30% glossy), paint
Dimensions	482 (w) x 132.6 (h) x 337 (d) mm
Weight	5.6 kg

\* 0 dB = 1 V

**Note:** The design and specifications are subject to change without notice for improvement.

### • Accessories

Rack mounting screw (5 x 12) .....	4
Fiber washer .....	4
Blank panel .....	9
Rack mounting bracket (preinstalled on the unit) .....	2
Standby amplifier cable (3 m) .....	1
Blank panel mounting screw .....	18

### • Optional product

Isolation transformer: IT-450 (audio link output)

## 2.9. Pilot Tone Detection Module VX-200SP

Power Source	Supplied from VX-2000SF
Current Consumption	Under 100 mA
Power Amplifier Link	RJ45 female connector for connecting the VP-2000 series or VP-3000 series Power Amplifier Twisted-pair straight cable (TIA/EIA-568A standard)
Line Monitor	Plug-in screw connector Applicable cable diameter: AWG 16 – AWG 24
External Attenuator Control output	Plug-in screw connector, relay, no-voltage make contact output, transfer type, withstand voltage: 30 V DC, 250 V AC, contact current: Under 7 A (DC), under 7 A (AC) Applicable cable diameter: AWG 16 – AWG 24
Speaker Output	Plug-in screw connector Applicable cable diameter: AWG 16 – AWG 24
Power Amplifier Input	Plug-in screw connector for connecting the VP-2000 series or VP-3000 series Power Amplifier Applicable cable diameter: AWG 16 – AWG 24
Fault Detection System	Short circuit, open circuit (pilot tone detection method), ground fault
Finish	Panel: Surface-treated steel plate
Dimensions	30.5 (w) x 132.6 (h) x 290.3 (d) mm
Weight	240 g
Applicable Model	VX-2000SF

**Note:** The design and specifications are subject to change without notice for improvement.

### • Accessory

Plug-in screw terminal ..... 1

### • Optional product

Equaliser card: VX-200SE

## 2.10. Impedance Detection Module VX-200SZ

Power Source	Supplied from VX-2000SF
Current Consumption	Under 150 mA
Power Amplifier Link	RJ45 female connector for connecting the VP-2000 series or VP-3000 series Power Amplifier. Twisted-pair straight cable (TIA/EIA-568A standard)
External Attenuator Control Output	Plug-in screw connector, relay, no-voltage make contact output, transfer type, withstand voltage: 30 V DC, 250 V AC, contact current: Under 7 A (DC), under 7 A (AC) Applicable cable diameter: AWG 16 – AWG 24
Speaker Output	Plug-in screw connector Applicable cable diameter: AWG 16 – AWG 24
Power Amplifier Input	Plug-in screw connector for connecting the VP-2000 series or VP-3000 series Power Amplifier Applicable cable diameter: AWG 16 – AWG 24
Fault Detection System	Short circuit, open circuit (impedance detection method), ground fault
Finish	Panel: Surface-treated steel plate
Dimensions	30.5 (w) x 132.6 (h) x 290.3 (d) mm
Weight	320 g
Applicable Model	VX-2000SF

**Note:** The design and specifications are subject to change without notice for improvement.

### • Accessory

Plug-in screw terminal ..... 1

### • Optional product

Equaliser card: VX-200SE

### 2.11. Equaliser Card VX-200SE

Power Source	Supplied from VX-200SZ, VX-200SP
Current Consumption	Under 50 mA
Equaliser Centre Frequency	80 Hz, 125 Hz, 250 Hz, 500 HZ, 1 kHz, 2 kHz, 4 kHz, 8 kHz, 12 kHz
Gain Range	±12 dB, adjustable in 2 dB steps
Dimensions	110 (w) x 90 (h) x 11.7 (d) mm
Weight	50 g
Applicable Model	VX-200SZ, VX-200SP

**Note:** The design and specifications are subject to change without notice for improvement.

### 2.12. Control Input Module VX-200SI

Power Source	Supplied from VX-2000SF
Current Consumption	Under 100 mA
Control Input	16 inputs, no-voltage make contact, open voltage: 24 V DC, short circuit current: under 10 mA, RJ45 connector
Finish	Panel: Surface-treated steel plate
Dimensions	30.5 (w) x 132.6 (h) x 290.3 (d) mm
Weight	200 g
Applicable Model	VX-2000SF

**Note:** The design and specifications are subject to change without notice for improvement.

### 2.13. Control Output Module VX-200SO

Power Source	Supplied from VX-2000SF
Current Consumption	Under 150 mA
Control Output	16 outputs, no-voltage make contact, contact capacity: 28 V DC, 1 A, RJ45 connector
Finish	Panel: Surface-treated steel plate
Dimensions	30.5 (w) x 132.6 (h) x 290.3 (d) mm
Weight	250 g
Applicable Model	VX-2000SF

**Note:** The design and specifications are subject to change without notice for improvement.

**2.14. Power Amplifier 4 x 60 W VP-2064**

Power Source	28 V DC (operating range: 20 – 40 V DC) M4 screw terminal, distance between barriers: 12 mm
Current Consumption (EN60065)	4.8 A in total
Rated Output Power	60 W x 4 (at min. resistive and max. capacitive load)
Output Power	45 W x 4 (at min. resistive and max. capacitive load) (at AC Mains of VX-200PS: 195.5 V) 60 W x 4 (at min. resistive and max. capacitive load) (at AC Mains of VX-3000DS: 187 V – 253 V)
Output Voltage	100 V (70 V, 50 V: selectable by internal wiring change)
Minimum Resistive Load	167 $\Omega$ (at 100 V), 83 $\Omega$ (at 70 V), 41 $\Omega$ (at 50 V)
Maximum Capacitive Load	0.125 $\mu$ F (at 100 V), 0.25 $\mu$ F (at 70 V), 0.5 $\mu$ F (at 50 V)
Number of Channels	4
Input	Specified by input module VP-200VX
Number of Module Slots	4
Usable Module	VP-200VX
Output	Power amplifier output (speaker line): M3.5 screw terminal, distance between barriers: 8.8 mm
Frequency Response	40 Hz – 16 kHz, $\pm$ 3 dB (at 1/3 rated output)
Distortion	1% or less (at rated output, 1 kHz)
Signal to Noise Ratio	80 dB or more
Panel Indicator	Channel power indicator: 4 channels, dual colour LED Overheat indicator: Yellow LED
Operating Temperature	0 to +40°C
Finish	Panel: Surface-treated steel plate, black (30% gloss), paint
Dimensions	482 (w) x 88.4 (h) x 340.5 (d) mm
Weight	11.2 kg

**Note:** The design and specifications are subject to change without notice for improvement.

• **Accessories**

Rack mounting screw (5 x 12) .....	4
Fiber washer.....	4



**2.15. Power Amplifier 2 x 120 W VP-2122**

Power Source	28 V DC (operating range: 20 – 40 V DC) M4 screw terminal, distance between barriers: 12 mm
Current Consumption (EN60065)	4.8 A in total
Rated Output Power	120 W x 2 (at min. resistive and max. capacitive load)
Output Power	90 W x 2 (at min. resistive and max. capacitive load) (at AC Mains of VX-200PS: 195.5 V) 120 W x 2 (at min. resistive and max. capacitive load) (at AC Mains of VX-3000DS: 187 V – 253 V)
Output Voltage	100 V (70 V, 50 V: selectable by internal wiring change)
Minimum Resistive Load	83 $\Omega$ (at 100 V), 41 $\Omega$ (at 70 V), 21 $\Omega$ (at 50 V)
Maximum Capacitive Load	0.25 $\mu$ F (at 100 V), 0.5 $\mu$ F (at 70 V), 1 $\mu$ F (at 50 V)
Number of Channels	2
Input	Specified by input module VP-200VX
Number of Module Slots	2
Usable Module	VP-200VX
Output	Power amplifier output (speaker line): M3.5 screw terminal, distance between barriers: 8.8 mm
Frequency Response	40 Hz – 16 kHz, $\pm$ 3 dB (at 1/3 rated output)
Distortion	1% or less (at rated output, 1 kHz)
Signal to Noise Ratio	80 dB or more
Panel Indicator	Channel power indicator: 2 channels, dual colour LED Overheat indicator: Yellow LED
Operating Temperature	0 to +40°C
Finish	Panel: Surface-treated steel plate, black (30% gloss), paint
Dimensions	482 (w) x 88.4 (h) x 340.5 (d) mm
Weight	9.1 kg

**Note:** The design and specifications are subject to change without notice for improvement.

**• Accessories**

Rack mounting screw (5 x 12) ..... 4  
Fiber washer ..... 4

**2.16. Power Amplifier 1 x 240 W VP-2241**

Power Source	28 V DC (operating range: 20 – 40 V DC) M4 screw terminal, distance between barriers: 12 mm
Current Consumption (EN60065)	4.8 A
Rated Output Power	240 W (at min. resistive and max. capacitive load)
Output Power	180 W (at min. resistive and max. capacitive load) (at AC Mains of VX-200PS: 195.5 V) 240 W (at min. resistive and max. capacitive load) (at AC Mains of VX-3000DS: 187 V – 253 V)
Output Voltage	100 V (70 V, 50 V: selectable by internal wiring change)
Minimum Resistive Load	41 $\Omega$ (at 100 V), 21 $\Omega$ (at 70 V), 10 $\Omega$ (at 50 V)
Maximum Capacitive Load	0.5 $\mu$ F (at 100 V), 1 $\mu$ F (at 70 V), 1 $\mu$ F (at 50 V)
Number of Channels	1
Input	Specified by input module VP-200VX
Number of Module Slots	1
Usable Module	VP-200VX
Output	Power amplifier output (speaker line): M3.5 screw terminal, distance between barriers: 8.8 mm
Frequency Response	40 Hz – 16 kHz, $\pm$ 3 dB (at 1/3 rated output)
Distortion	1% or less (at rated output, 1 kHz)
Signal to Noise Ratio	80 dB or more
Panel Indicator	Channel power indicator: 1 channel, dual colour LED Overheat indicator: Yellow LED
Operating Temperature	0 to +40°C
Finish	Panel: Surface-treated steel plate, black (30% gloss), paint
Dimensions	482 (w) x 88.4 (h) x 340.5 (d) mm
Weight	8.1 kg

**Note:** The design and specifications are subject to change without notice for improvement.

**• Accessories**

Rack mounting screw (5 x 12) .....	4
Fiber washer .....	4

**2.17. Power Amplifier 1 x 420 W VP-2421**

Power Source	28 V DC (operating range: 20 – 40 V DC) M4 screw terminal, distance between barriers: 12 mm
Current Consumption (EN60065)	7.6 A
Rated Output Power	420 W (at min. resistive and max. capacitive load)
Output Power	320 W (at min. resistive and max. capacitive load) (at AC Mains of VX-200PS: 195.5 V) 420 W (at min. resistive and max. capacitive load) (at AC Mains of VX-3000DS: 187 V – 253 V)
Output Voltage	100 V (70 V, 50 V: selectable by internal wiring change)
Minimum Resistive Load	24 $\Omega$ (at 100 V), 12 $\Omega$ (at 70 V), 6 $\Omega$ (at 50 V)
Maximum Capacitive Load	0.5 $\mu$ F (at 100 V), 1 $\mu$ F (at 70 V), 1 $\mu$ F (at 50 V)
Number of Channels	1
Input	Specified by input module VP-200VX
Number of Module Slots	1
Usable Module	VP-200VX
Output	Power amplifier output (speaker line): M3.5 screw terminal, distance between barriers: 8.8 mm
Frequency Response	40 Hz – 16 kHz, $\pm$ 3 dB (at 1/3 rated output)
Distortion	1% or less (at rated output, 1 kHz)
Signal to Noise Ratio	80 dB or more
Panel Indicator	Channel power indicator: 1 channel, dual colour LED Overheat indicator: Yellow LED
Operating Temperature	0 to +40°C
Finish	Panel: Surface-treated steel plate, black (30% gloss), paint
Dimensions	482 (w) x 88.4 (h) x 340.5 (d) mm
Weight	9.5 kg

**Note:** The design and specifications are subject to change without notice for improvement.

**• Accessories**

Rack mounting screw (5 x 12) .....	4
Fiber washer .....	4

**2.18. Digital Power Amplifier 4 x 150 W VP-3154**

Power Source	31 V DC (operating 20 – 34 V DC) DC power in: M4 screw terminal, distance between barriers: 11 mm
Amplification System	Class D
Current Consumption	6 A in total at 31 V DC (EN60065)
Rated Output Power	150 W x 4 (at 100 line and min. resistive and max. capacitive load) 105 W x 4 (at 70 line and min. resistive and max. capacitive load) 75 W x 4 (at 50 line and min. resistive and max. capacitive load) (at AC Mains of VX-3000DS: 187 V – 253 V)
Output Voltage	100 V (70 V, 50 V: selectable by internal change)
Minimum Resistive Load	67 $\Omega$ (at 100 V line), 47 $\Omega$ (at 70 V line), 33 $\Omega$ (at 50 V line)
Maximum Capacitive Load	0.5 $\mu$ F
Number of Channels	4
Input	PA Link: 4 channels, RJ45 connector BGM: 4 channels, removable terminal block (5 pins) BGM INPUT (H, C, E): $-10$ dB*/0 dB* (LINE, changeable), 22 k $\Omega$ , electronically balanced BGM MUTE (G, +): no-voltage make contact input, open voltage: 15 V DC, short-circuit current: 2 mA Volume adjustment: 4 channels
Output	PA OUT (speaker line): removable terminal block (9 pins) x 1
Frequency Response	40 Hz – 16 kHz, $\pm 3$ dB (at 100 V line, 1/3 rated output)
Distortion	1% or less (at 100 V line, rated output, 1 kHz)
Signal to Noise Ratio	80 dB or more (at 100 V line, A-weighted)
Crosstalk	60 dB or more (at 100 V line, A-weighted)
Panel Indicator	Power indicator: 4 channels, green LED Operation indicator: 4 channels, green LED Input signal indicator: 4 channels, green LED Peak signal indicator: 4 channels, red LED
Operating Temperature	$-5$ to $+45^{\circ}$ C
Operating Humidity	90%RH or less (no condensation)
Finish	Panel: Surface-treated steel plate, black, 30% gloss, paint
Dimensions	482 (w) x 88.4 (h) x 390 (d) mm
Weight	7.3 kg

\* 0 dB = 1 V

**Note:** The design and specifications are subject to change without notice for improvement.**• Accessories**

Rack mounting screw (with plain washer) 5 x 12 .....	4
Removable terminal plug (5 pins) .....	4
Removable terminal plug (9 pins) .....	1

**2.19. Digital Power Amplifier 4 x 300 W VP-3304**

Power Source	31 V DC (operating 20 – 34 V DC) DC power in: M4 screw terminal, distance between barriers: 11 mm
Amplification System	Class D
Current Consumption	9 A in total at 31 V DC (EN60065)
Rated Output Power	300 W x 4 (at 100 V line and min. resistive and max. capacitive load) 210 W x 4 (at 70 V line and min. resistive and max. capacitive load) 150 W x 4 (at 50 V line and min. resistive and max. capacitive load) (at AC Mains of VX-3000DS: 187 V – 253 V)
Output Voltage	100 V (70 V, 50 V: selectable by internal change)
Minimum Resistive Load	33 $\Omega$ (at 100 V line), 23 $\Omega$ (at 70 V line), 17 $\Omega$ (at 50 V line)
Maximum Capacitive Load	0.5 $\mu$ F
Number of Channels	4
Input	PA Link: 4 channels, RJ45 connector BGM: 4 channels, removable terminal block (5 pins) BGM INPUT (H, C, E): -10 dB* / 0 dB* (LINE, changeable), 22 k $\Omega$ , electronically balanced BGM MUTE (G, +): no-voltage make contact input, open voltage: 15 V DC, short-circuit current: 2 mA Volume adjustment: 4 channels
Output	PA OUT (speaker line): removable terminal block (9 pins) x 1
Frequency Response	40 Hz – 16 kHz, $\pm$ 3 dB (at 100 V line, 1/3 rated output)
Distortion	1% or less (at 100 V line, rated output, 1 kHz)
Signal to Noise Ratio	80 dB or more (at 100 V line, A-weighted)
Crosstalk	60 dB or more (at 100 V line, A-weighted)
Panel Indicator	Power indicator: 4 channels, green LED Operation indicator: 4 channels, green LED Input signal indicator: 4 channels, green LED Peak signal indicator: 4 channels, red LED
Operating Temperature	-5 to +45°C
Operating Humidity	90%RH or less (no condensation)
Finish	Panel: Surface-treated steel plate, black, 30% gloss, paint
Dimensions	482 (w) x 88.4 (h) x 390 (d) mm
Weight	7.3 kg

\* 0 dB = 1 V

**Note:** The design and specifications are subject to change without notice for improvement.**• Accessories**

Rack mounting screw (with plain washer) 5 x 12 .....	4
Removable terminal plug (5 pins) .....	4
Removable terminal plug (9 pins) .....	1

**2.20. Digital Power Amplifier 4 x 500 W VP-3504**

Power Source	31 V DC (operating 20 – 34 V DC) DC power in: M4 screw terminal, distance between barriers: 11 mm
Amplification System	Class D
Current Consumption	13 A in total at 31 V DC (EN60065)
Rated Output Power	500 W x 4 (at 100 V line and min. resistive and max. capacitive load) 350 W x 4 (at 70 V line and min. resistive and max. capacitive load) 250 W x 4 (at 50 V line and min. resistive and max. capacitive load) (at AC Mains of VX-3000DS: 187 V – 253 V)
Output Voltage	100 V (70 V, 50 V: selectable by internal change)
Minimum Resistive Load	20 Ω (at 100 V line), 14 Ω (at 70 V line), 10 Ω (at 50 V line)
Maximum Capacitive Load	0.5 μF
Number of Channels	4
Input	PA Link: 4 channels, RJ45 connector BGM: 4 channels, removable terminal block (5 pins) BGM INPUT (H, C, E): –10 dB*/0 dB* (LINE, changeable), 22 kΩ, electronically balanced BGM MUTE (G, +): no-voltage make contact input, open voltage: 15 V DC, short-circuit current: 2 mA Volume adjustment: 4 channels
Output	PA OUT (speaker line): removable terminal block (9 pins) x 1
Frequency Response	40 Hz – 16 kHz, ±3 dB (at 100 V line, 1/3 rated output)
Distortion	1% or less (at 100 V line, rated output, 1 kHz)
Signal to Noise Ratio	80 dB or more (at 100 V line, A-weighted)
Crosstalk	60 dB or more (at 100 V line, A-weighted)
Panel Indicator	Power indicator: 4 channels, green LED Operation indicator: 4 channels, green LED Input signal indicator: 4 channels, green LED Peak signal indicator: 4 channels, red LED
Operating Temperature	–5 to +45°C
Operating Humidity	90%RH or less (no condensation)
Finish	Panel: Surface-treated steel plate, black, 30% gloss, paint
Dimensions	482 (w) x 88.4 (h) x 390 (d) mm
Weight	7.7 kg

\* 0 dB = 1 V

**Note:** The design and specifications are subject to change without notice for improvement.**• Accessories**

Rack mounting screw (with plain washer) 5 x 12 .....	4
Removable terminal plug (5 pins) .....	4
Removable terminal plug (9 pins) .....	1

## 2.21. Power Amplifier Input Module VP-200VX

Power Source	Supplied from VP-2064, VP-2122, VP-2241, VP-2421
Current Consumption	Under 30 mA
Power Amplifier Link	RJ45 female connector for connecting the VX-200SP or VX-200SZ Audio output module Twisted-pair straight cable (TIA/EIA-568A standard)
Finish	Panel: Surface-treated steel plate
Dimensions	88 (w) x 25.8 (h) x 73.2 (d) mm
Weight	50 g
Applicable Model	VP-2064, VP-2122, VP-2241, VP-2421

\* 0 dB = 1 V

**Note:** The design and specifications are subject to change without notice for improvement.

## 2.22. Wall Mounting Bracket WB-RM200

Finish	Surface treated steel plate, black, paint
Weight	100 g
Set Composition	Mount bracket ..... 1
Usable Unit	RM-200X, RM-200M, RM-210

**Note:** The design and specifications are subject to change without notice for improvement.

### • Accessories

Self-tapping screw (4 x 25) .....	2
Machine screw M3.5 x 20 .....	2

